

Welcome

REDERIJ DOEKSEN



Welcome

Richard de Vries

Manager Operations at Rederij Doeksen since 2007

- Operational management fleet + quay personnel
- Continuity and safety ferry service
- Maintenance of ships and shore facilities



Rederij Doeksen

- Founded 1908: shell dredging & salvage
- Since 1923: passenger service
- Public transport contract 2014 – 2029
- In 2017: 211 fte
- In 2017 transporting 669k tourists + 106k residents

History of unorthodox solutions en new technologies



Rederij Doeksen

Current fleet

Operating: 3 ropax ferries;
2 fast ferries
1 roro catamaran (roro freight only)
1 water taxi

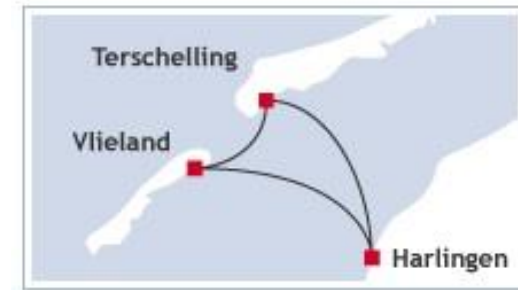

New vessels



New vessels

Environmental innovation

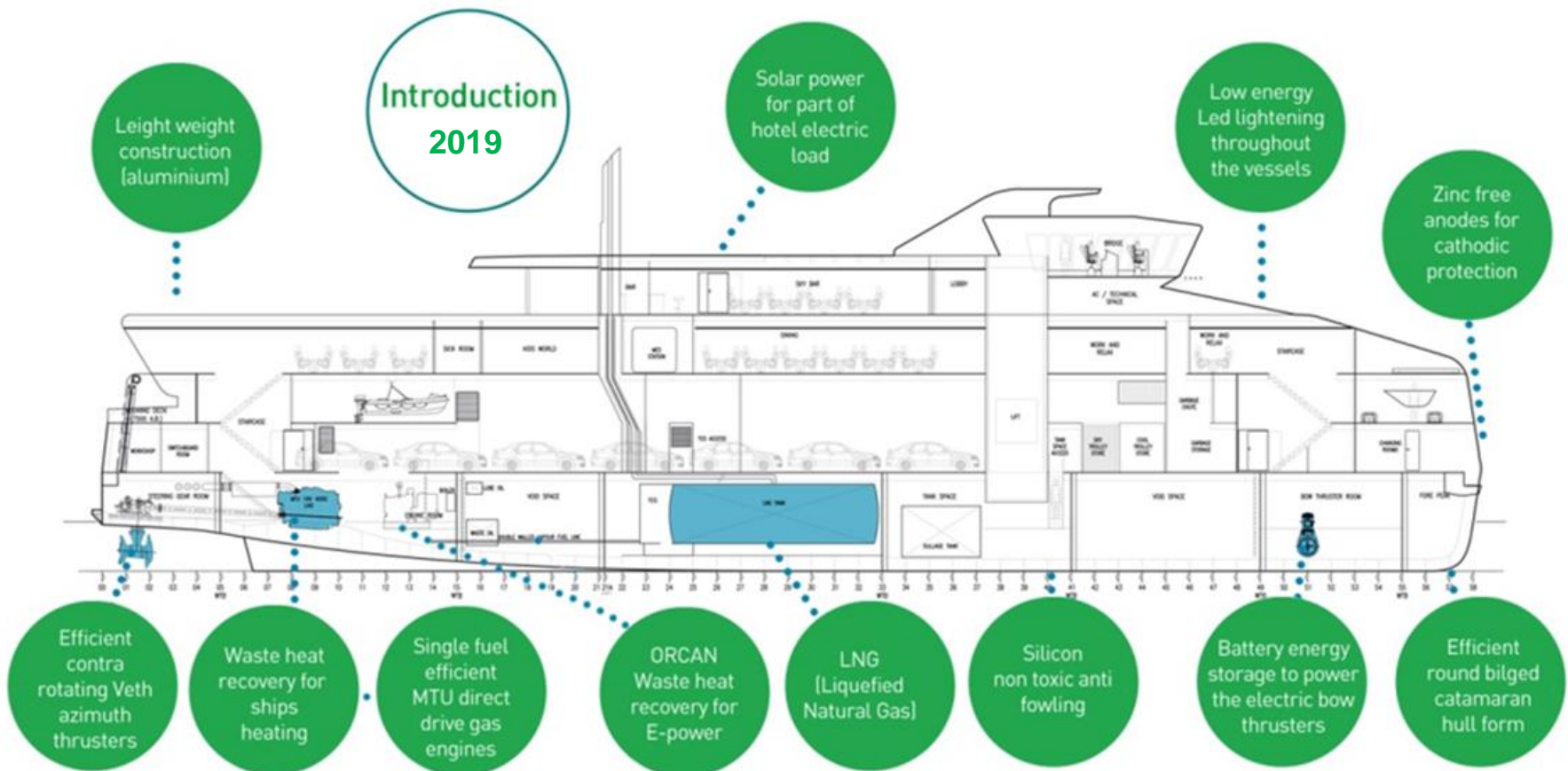

New vessels

Environmental innovation

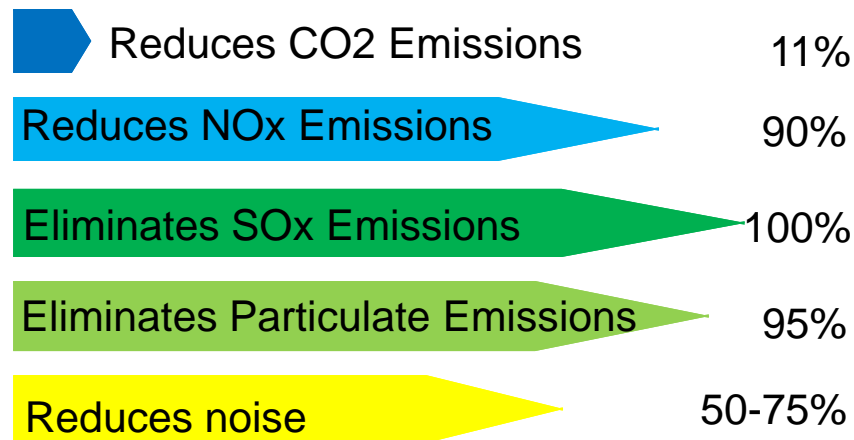

Orcan ePacks convert waste heat from engines to CO2-free electricity:

- significant reduction of fuel consumption
- substantial reduction of environmental footprint

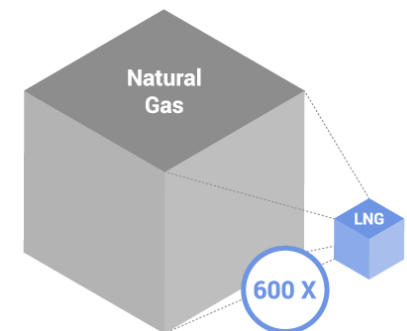
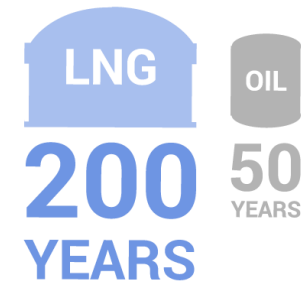
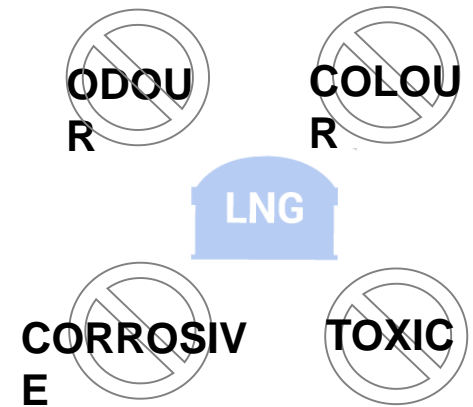

New vessels



New vessels

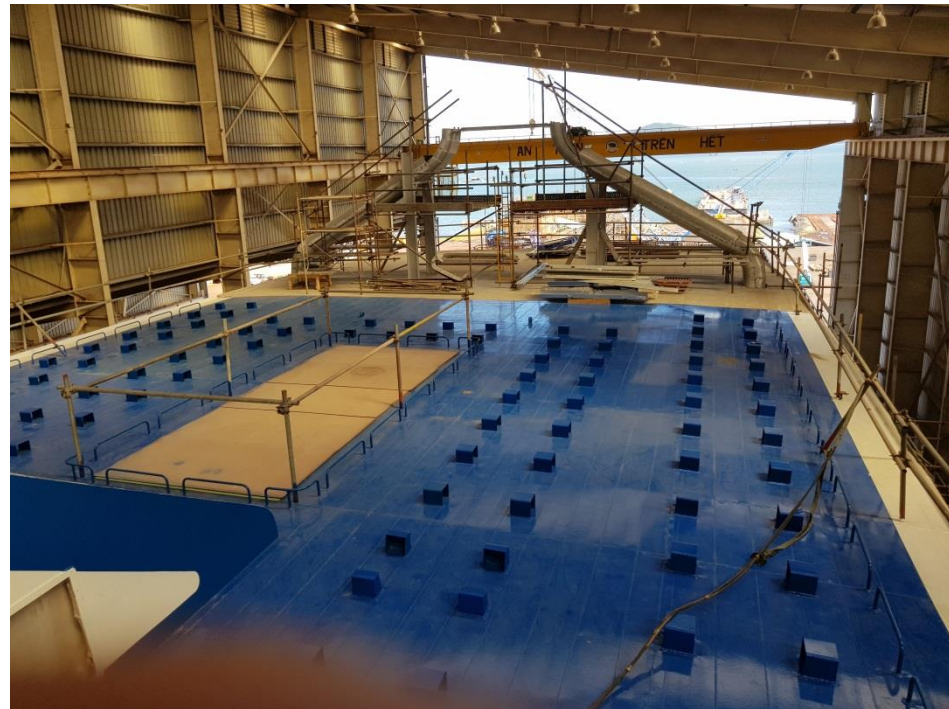

New vessels



New vessels



New vessels

Timing of entry into service

Expected	
Dec. 2018	Ships ready for transportation from Vietnam to The Netherlands
Jan. 2019	Arrival two ships in Harlingen (NL)
Feb/March 2019	Sea trials
March/Apr 2019	Hand over of vessels
April/May 2019	Ships enter sailing schedule

Thank you for your
attention