



Strategy Paper

Towards frequent, reliable and integrated long-distance services along the Berlin – Poznań – Warsaw – Białystok
Commuting Growth Corridor



EUROPEAN UNION

EUROPEAN
REGIONAL
DEVELOPMENT
FUND



CONTENTS

- Background and aims of the Strategy Paper
- Challenges and needs for the development of the Berlin – Poznań – Warsaw – Białystok Commuting Growth Corridor
- Strategy elements: Infrastructure – Node development – Rolling stock – Design and funding of offers
- Conclusions

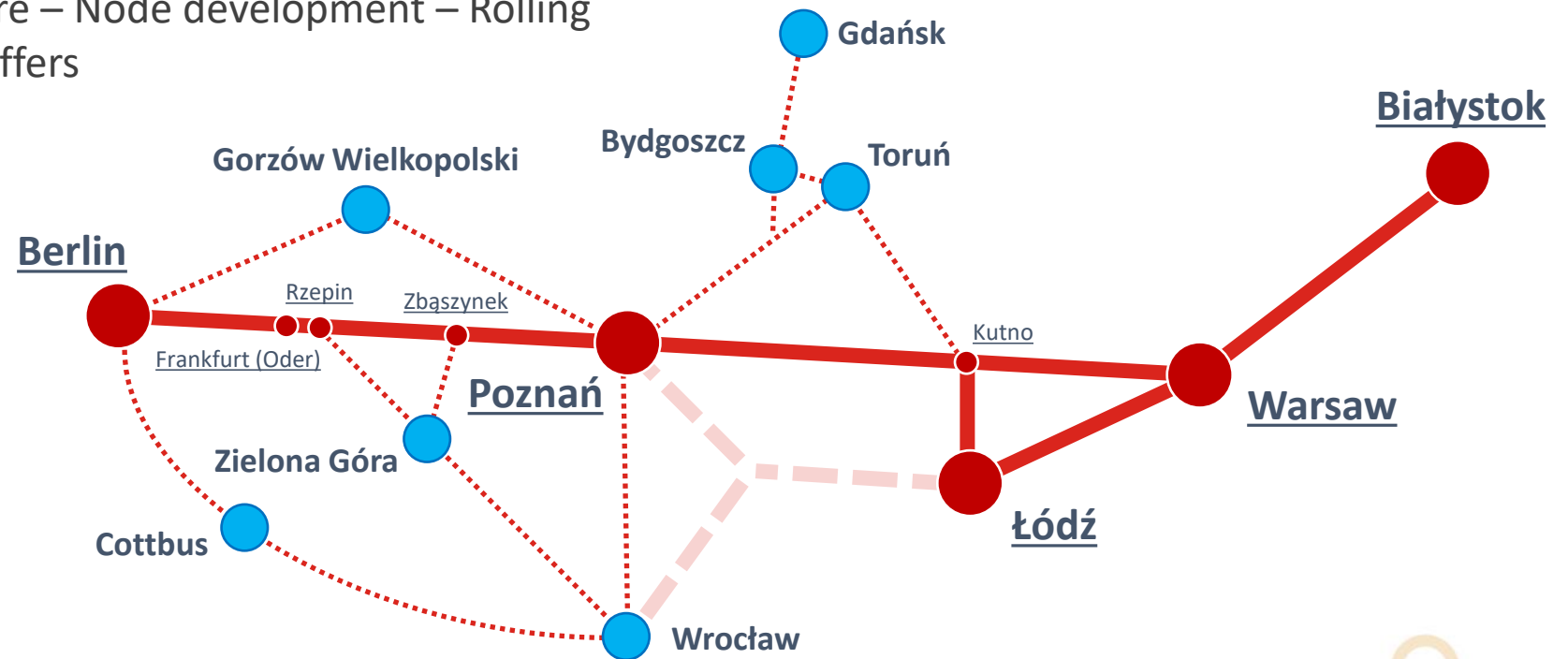

BACKGROUND AND AIMS OF THE STRATEGY PAPER

- The strategy paper summarises the results and findings of works and studies on long-distance passenger rail transport between Berlin, Poznań, Warsaw and Białystok
- It is based on a comprehensive analysis of infrastructure development, connecting functions of urban nodes and travel offers along the corridor Berlin – Białystok and the continuous monitoring of developments in the field of railway transport between Germany and Poland
- Additionally, two supporting expert studies have been prepared:
 - Feasibility study for an eligible model for sustainable and operator-neutral provision of cross-border rolling stock (ETC Transport Consultants GmbH, February 2018)
 - Analysis of potentials for capacity optimization of the railway line Berlin – Frankfurt (Oder) – Rzepin to meet the growing needs of regional, long-distance and rail freight transport along the TEN-T Core Network Corridor (CNC) North Sea – Baltic (Ramboll GmbH, August 2019)
- The aim of the strategy paper is to provide incentives and inspiration for the improvement of passenger rail transport between Germany and Poland, taking advantage of synergies between regional and long-distance transport

CHALLENGES AND NEEDS FOR DEVELOPMENT

- Infrastructure upgrades (160-200 km/h) are being prepared or in process of implementation. The results will be increased capacity and reduced travel times
- Growing demand for regional transport, in particular in metropolitan areas (Berlin, Poznań, Łódź, Warsaw). Need for more capacity of railway infrastructure in urban nodes
- Limited availability of cross-border rolling stock for long-distance passenger rail services (lack of multi-system locomotives). Lack of multi-system electric multiple units for cross-border regional transport
- Different approaches towards design of travel offers (interval timetable vs. point-to-point connections and different funding systems for regional and long-distance transport in Germany and Poland)



*Urgent need for substantial
modal shift in passenger
and freight transport*

STRATEGY ELEMENTS

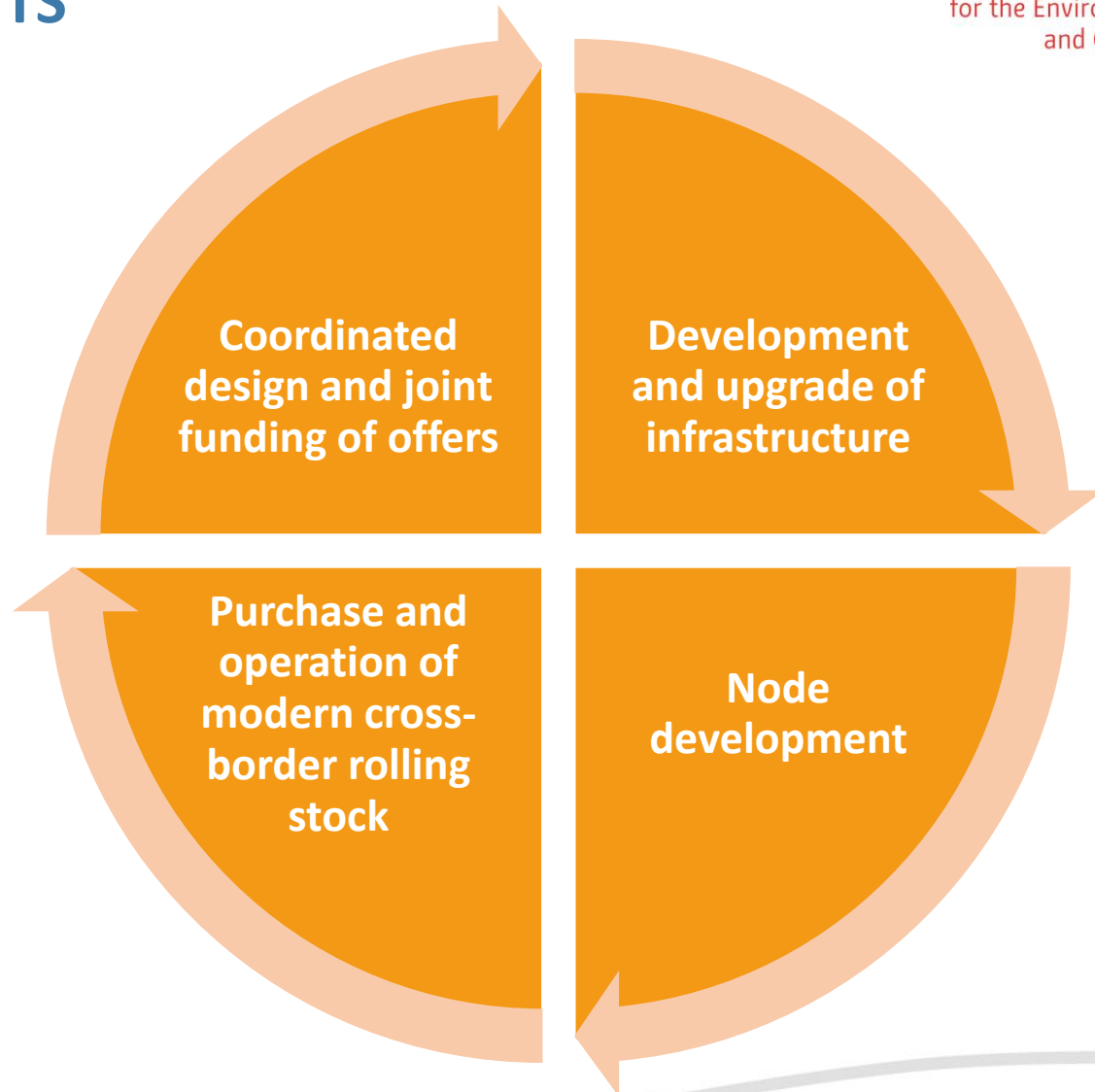

DEVELOPMENT AND UPGRADE OF INFRASTRUCTURE

- Warsaw – Białystok: Upgrade of railway line for 200 km/h (removal of level crossings), increase of axle load to 22,5 t
 - 1st stage: Warszawa Rembertów – Tłuszcz (Sadowne), nearly finalised
 - 2nd stage: Sadowne – Czyżew, under construction
 - 3rd stage: Czyżew – Białystok, in process of preparation
- Warsaw – Poznań (Sochaczew – Swarzędz): Upgrade of railway line for 160 km/h, increase of axle load to 22,5 t
 - 1st stage: Closure of the railway line Września – Barłogi (2017-2019)
 - Finalisation of works planned until the end of 2020
- Poznań – State border D/PL: Feasibility study for upgrade in preparation, considering the following issues:
 - Upgrade of railway line for 200 km/h between Poznań Górczyń and Szczaniec
 - Feasibility of railway bypass near Zbąszynek
 - Construction of additional tracks Poznań – Opalenica

DEVELOPMENT AND UPGRADE OF INFRASTRUCTURE

- Situation analysis of railway lines in the German-Polish border area, prepared by the Transport Working Group of the Committee for Cross-border Cooperation of the German-Polish Intergovernmental Commission (05/2018)
- Directions of development: Construction of 2nd track and electrification of cross-border railway lines

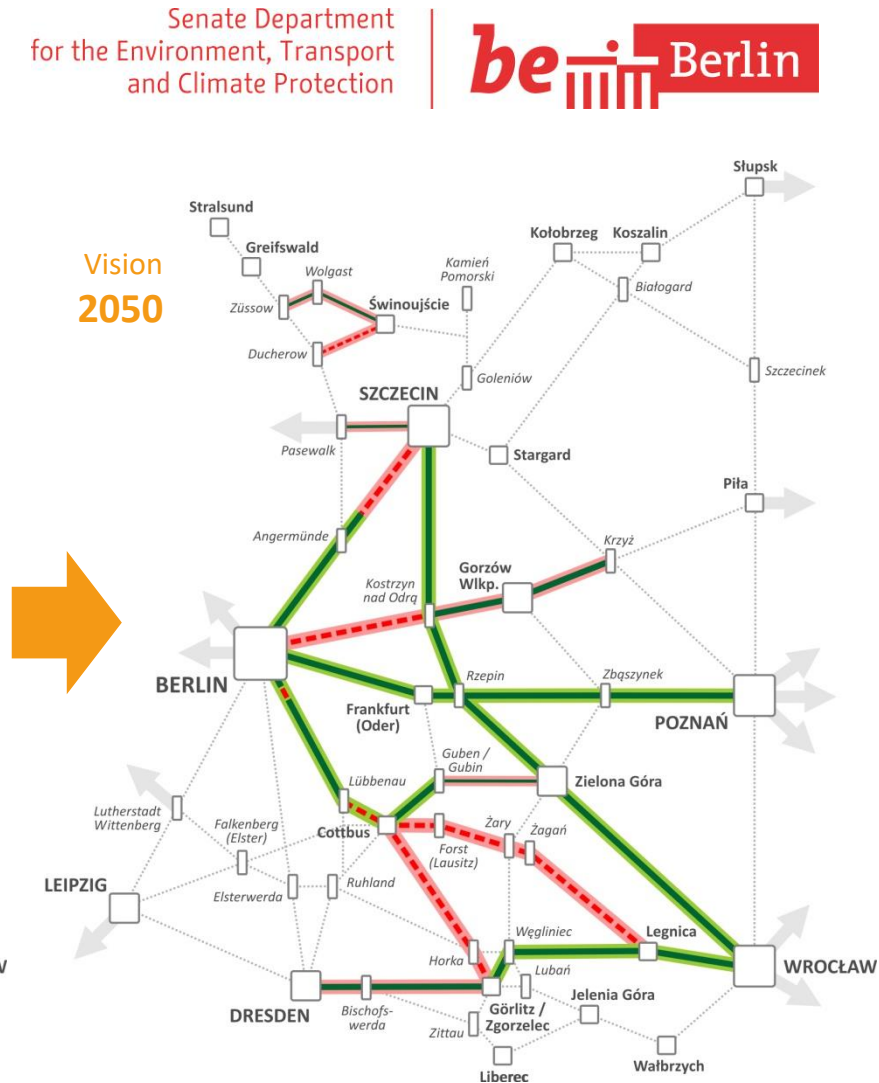
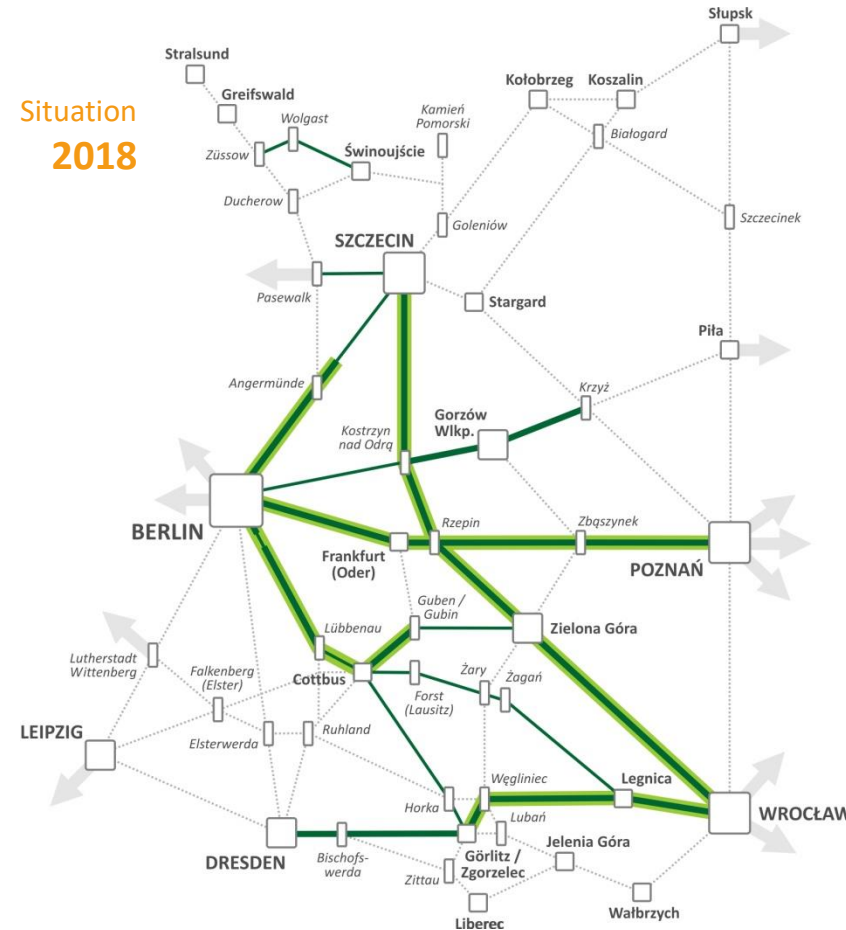

DEVELOPMENT AND UPGRADE OF INFRASTRUCTURE

- New impulses through structural change in former coal regions in Germany – additional infrastructure investments planned in the Lusatia region, including crucial cross-border relations
- Investments to be implemented until 2038, most interesting projects:
 - Berlin – Cottbus – Görlitz: Construction of 2nd track and electrification, 160-200 km/h
 - Dresden – Görlitz: Electrification, with priority electrification of the Görlitz railway station (until 2026)
- Planned upgrades between Leipzig, Dresden and Cottbus and Guben and Zielona Góra facilitate the development of long-distance services between Leipzig, Dresden and Poznań (relief of the Berlin node)
- Yet unclear perspective of implementation:
 - Cross-border links between Mecklenburg-Vorpommern and the Western Pomeranian Voivodship
 - Berlin – Kostrzyn – Gorzów Wlkp. – Krzyż („Prussian Eastern Railway”)
 - Forst (Lausitz) – Żary – Żagań – Legnica

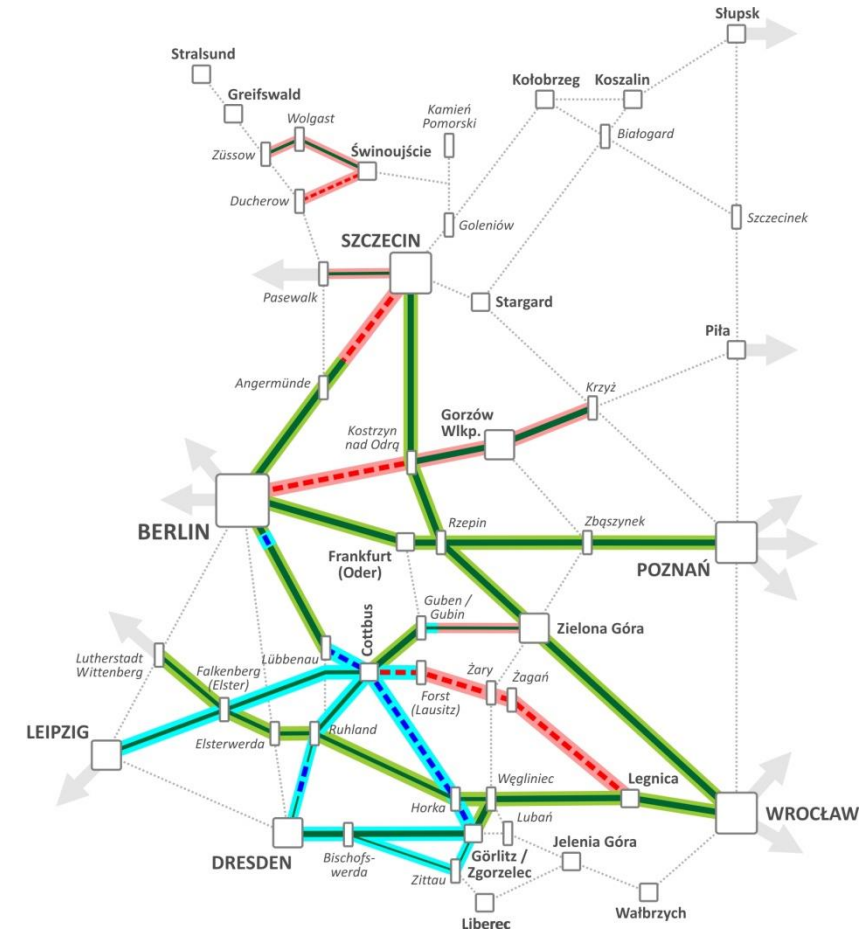

DEVELOPMENT AND UPGRADE OF INFRASTRUCTURE

- Berlin – Frankfurt (Oder) – State border D/PL: Upgrade for 120-160 km/h nearly finalised, ETCS to be installed until 2023
- Upgrade of the junction with Berlin freight ring through construction of 3rd track in Berlin-Köpenick (more efficient operation of freight trains) to be finalised until 2026
- Recommendations from analysis of potentials for capacity optimization:
 - Need for precise and capacity-oriented scheduling and operation of trains; track speed should not increase beyond 160 km/h
 - Further increase of capacity of junction with the Berlin freight ring possible (construction of 2nd track on the junction)
 - Additional overhaul track near Hangelsberg useful (in case of delays)
 - Need for upgrade of Oderbrücke station (740 m tracks, additional tracks) for efficient operation of trains
 - If number of freight trains increases: upgrade for railway line Berlin – Kostrzyn – Krzyż before construction of 3rd track

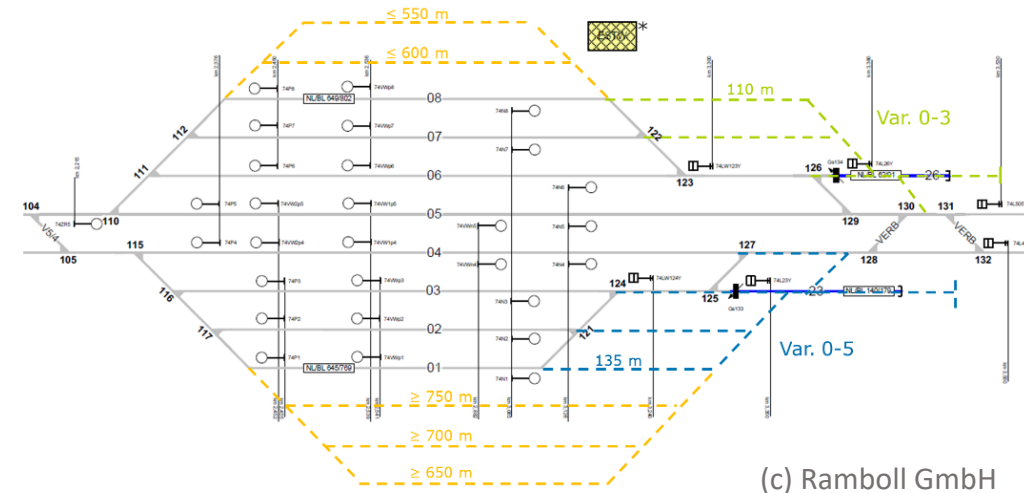

DEVELOPMENT AND UPGRADE OF INFRASTRUCTURE

- „Roadmap” for upgrade and operation of the railway lines Berlin – Frankfurt (Oder) – State border D/PL and Berlin – Kostrzyn – Gorzów Wlkp. – Krzyż

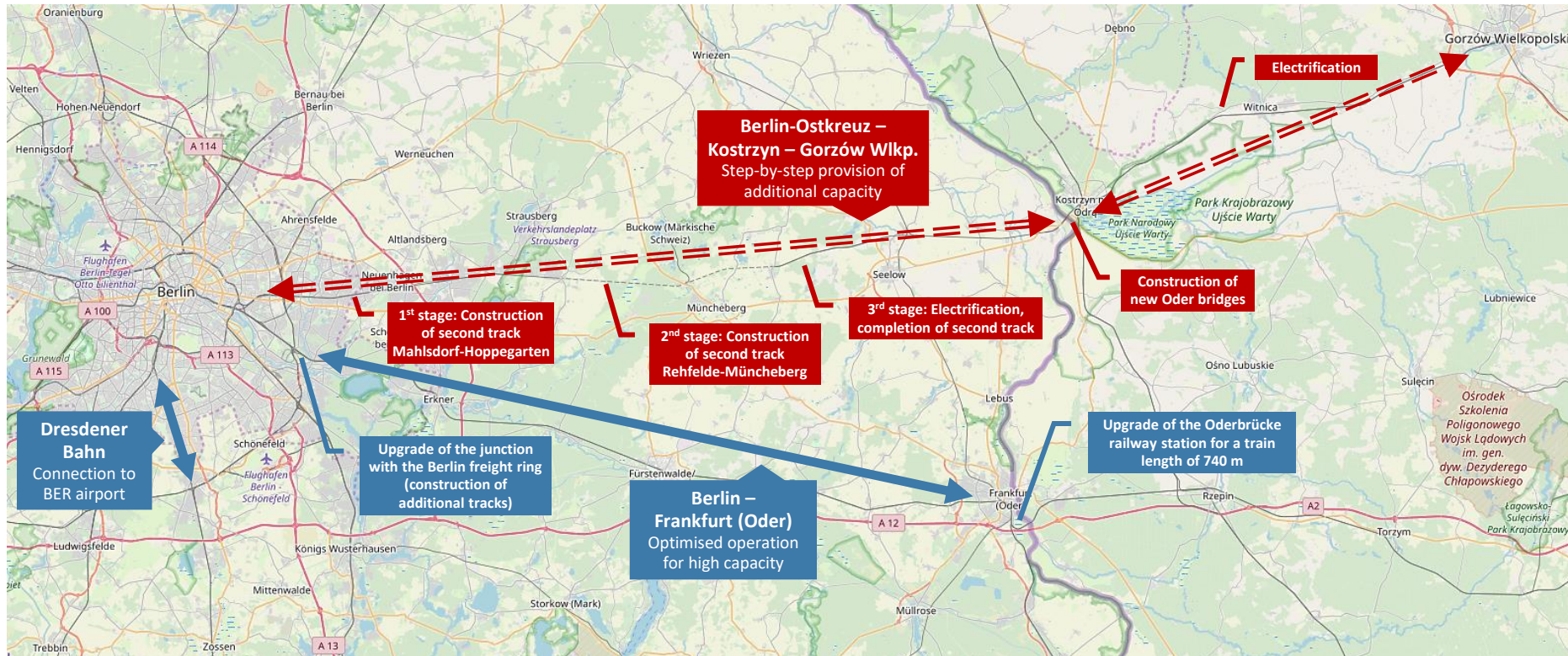

DEVELOPMENT AND UPGRADE OF INFRASTRUCTURE

- Renaissance of the discussion on high-speed railway lines in Poland through development of the Central Communication Hub (Centralny Port Komunikacyjny, CPK) between Warsaw and Łódź
- Key elements („hub and spoke”):
 - Relocation of the Warsaw airport and development as trans-European airport hub
 - Construction of complementary network of high-speed railway lines (upgrade of existing and construction of new railway lines)
- 1st stage: New high-speed railway line Łódź – Warsaw
- 2nd and further stages: Construction of the Y project and further railway lines, particular focus on the modernisation of railway lines (revised Y project)
- New perspectives for high-speed services between Germany and Poland, further development needs to be observed

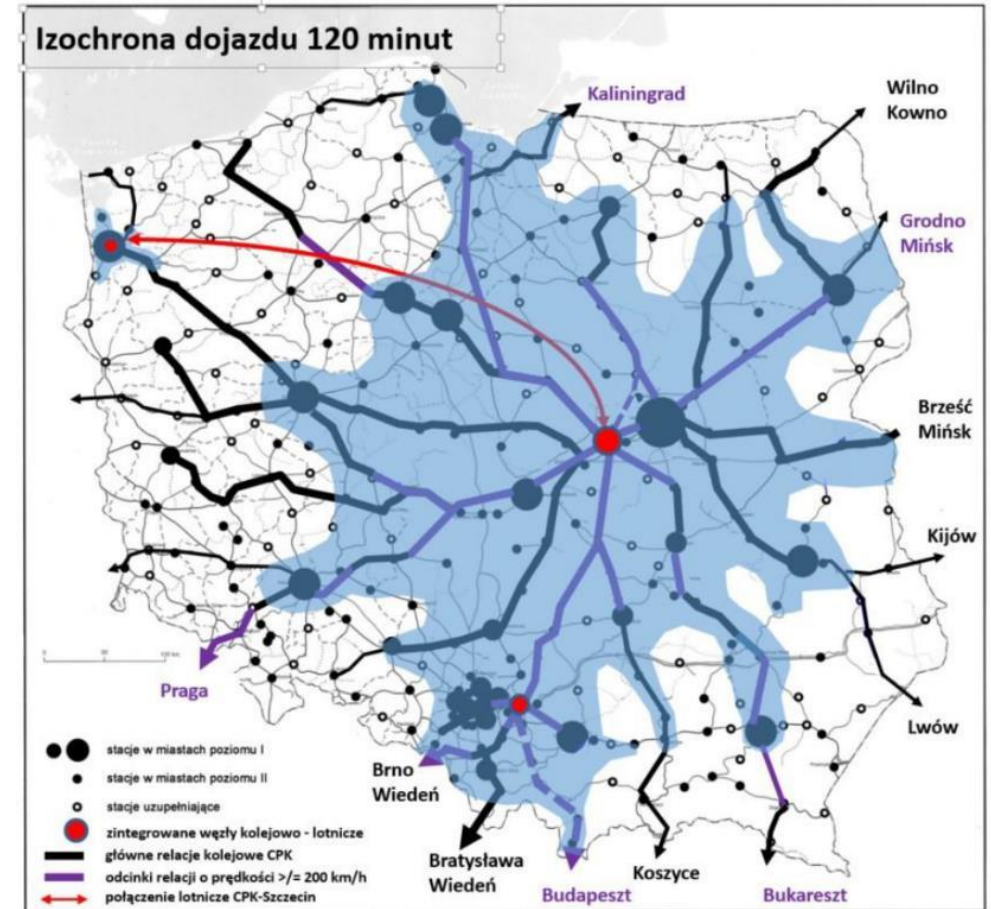

(c) CPK

NODE DEVELOPMENT – BERLIN

- To upgrade the railway infrastructure in the Berlin node for growing demand in regional and urban transport, currently the i2030 project is in process of realisation
- Within the i2030 project, infrastructure improvements are being prepared along 7 growth corridors in the Berlin metropolitan area and in the urban railway system (S-Bahn)
- Main focus is the realisation of planning processes for the preparation of investment measures
- Along the railway line Berlin – Frankfurt (Oder) railway stations need to be prepared for a train length of 210 m
- Additionally, 3 trains / hour will be offered between Berlin and Frankfurt (Oder) during peak hours beginning in 12/2022

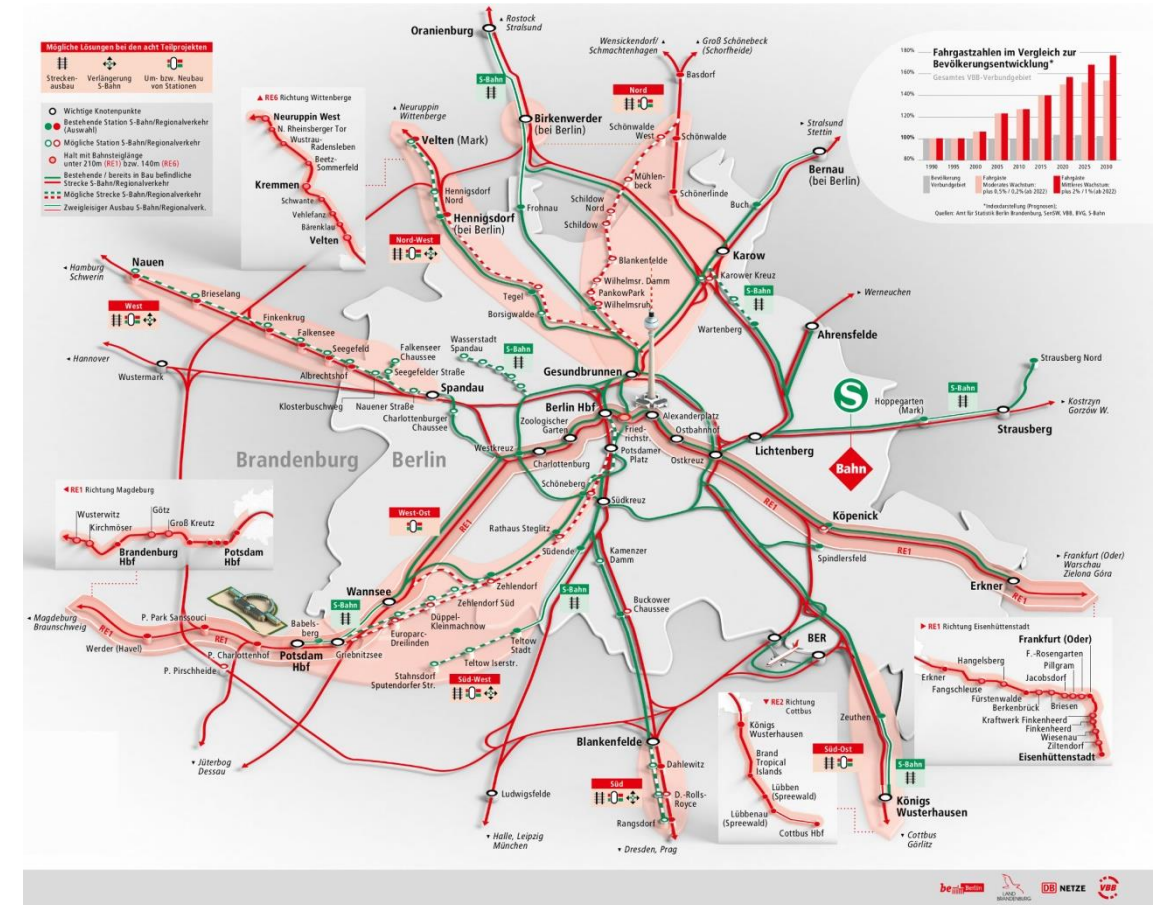

(c) i2030

NODE DEVELOPMENT – POZNAŃ

- Poznań main station is the most important interchange station in Poland with connections to all parts of Poland
- Need for extension of infrastructure capacity in the railway node due to growing transport volumes and development of the Poznań Metropolitan Railway (Poznańska Kolej Metropolitalna, PKM)
- Currently a feasibility study for extension of the railway node is being prepared. Selected issues:
 - Construction of additional tracks for metropolitan transport, improvement of track layout of several railway stations
 - Activation of the Poznań freight bypass for regional transport
- Additionally, there is need to find suitable solutions for the handling of passengers, since the size and capacity of the new station building does not correspond to the importance of the railway station

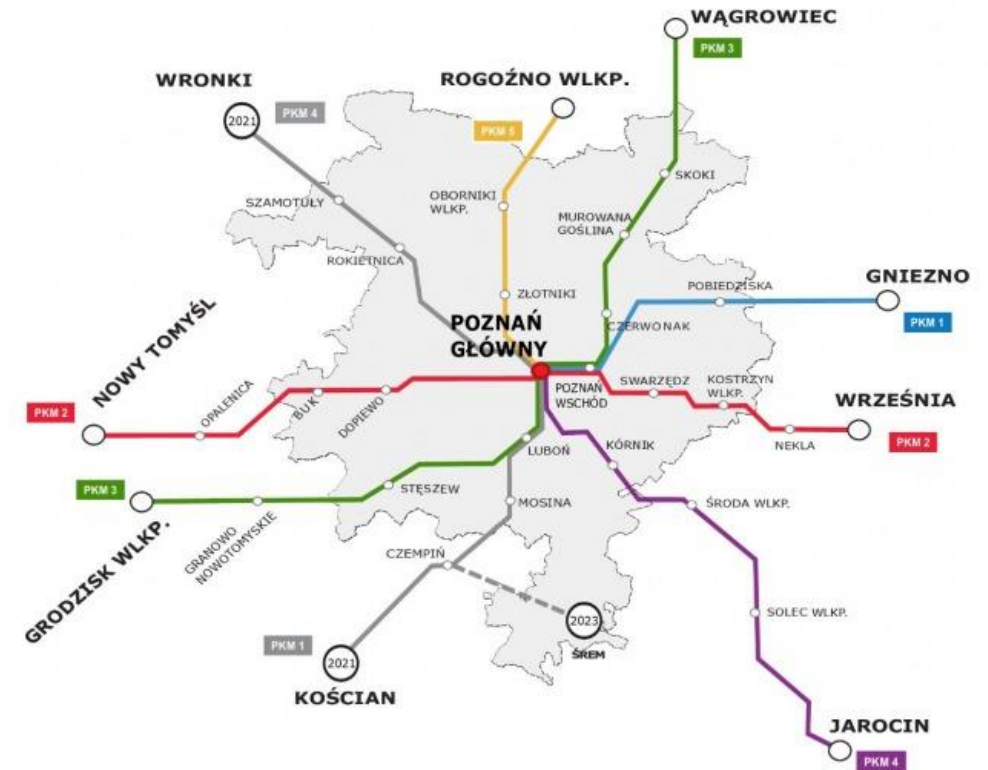

(c) PKM

NODE DEVELOPMENT – ŁÓDŹ

- The Łódź railway node will be re-shaped through the construction of the city tunnel
- Instead of several „main” stations, the Łódź Fabryczna station will become the main station of Łódź, and the operation of the railway system will be much more efficient than today
- To capitalise the effects of the city tunnel, the feeder lines of the Łódź Agglomeration Railway (Łódzka Kolej Aglomeracyjna, ŁKA) need to be upgraded (ongoing)
- Until 2023, the railway line Łódź – Kutno will be revitalised and modernised (100-120 km/h). Subsequently, it is planned to increase the speed level to 160 km/h and to add a 2nd track between Zgierz and Kutno
- It is expected that the construction of the Central Communication Hub (Centralny Port Komunikacyjny, CPK) will boost urban development in the Łódź agglomeration

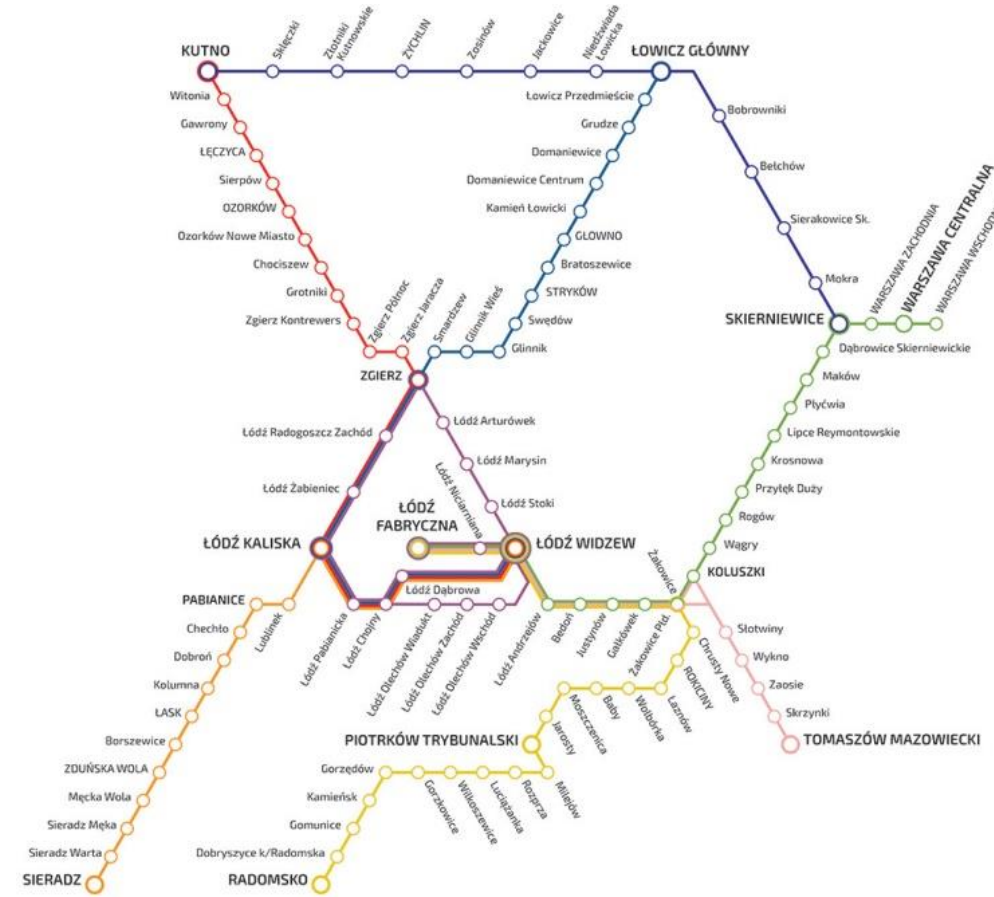

(c) ŁKA

NODE DEVELOPMENT – WARSAW

- The Warsaw railway node is the most important railway node for regional and long-distance transport in Poland
- The Warsaw cross-city line („linia średnicowa”) Warszawa Zachodnia – Warszawa Wschodnia is the backbone of the railway node and a crucial bottleneck
- The complex modernisation of the cross-city line is currently being prepared, leading to a long-term investment process. Selected elements are:
 - Reconstruction (revitalisation) of Warszawa Główna station
 - Removal of stations and construction of additional stations
 - Significant increase of capacity of all railway lines, check of feasibility of extension of WKD railway line
- To prepare further development of the Warsaw railway node, a Master Plan for the development of the railway transport in the Warsaw agglomeration has been elaborated (05/2019)



PURCHASE AND OPERATION OF MODERN CROSS-BORDER ROLLING STOCK

- Available cross-border rolling stock, which is suitable for long-distance connections between Germany and Poland:
 - PKP Intercity: 10 Siemens Husarz EU44 multi-system locomotives (purchase of additional multi-system locomotives planned), 20 Alstom Pendolino ED250 high-speed trains (approval for operation in Germany in process)
 - DB Fernverkehr: Lack of suitable rolling stock
- Besides these railcars, only diesel multiple units (DMU) are available, which are not suitable for long-distance connections
- Locomotive-hauled trains are most efficient on long-distance connections with few stops and high demand
- There is lack of multi-system electric multiple units (EMU) for regional and long-distance connections with more frequent connections and lower demand

PURCHASE AND OPERATION OF MODERN CROSS-BORDER ROLLING STOCK

- Multi-system electric multiple units could be operated by long-distance operators as well as operators of regional transport
- Most efficient solution would be to create a pool of cross-border railcars, which could be managed flexibly according to needs of long-distance and regional transport, taking into account progress of electrification of cross-border lines

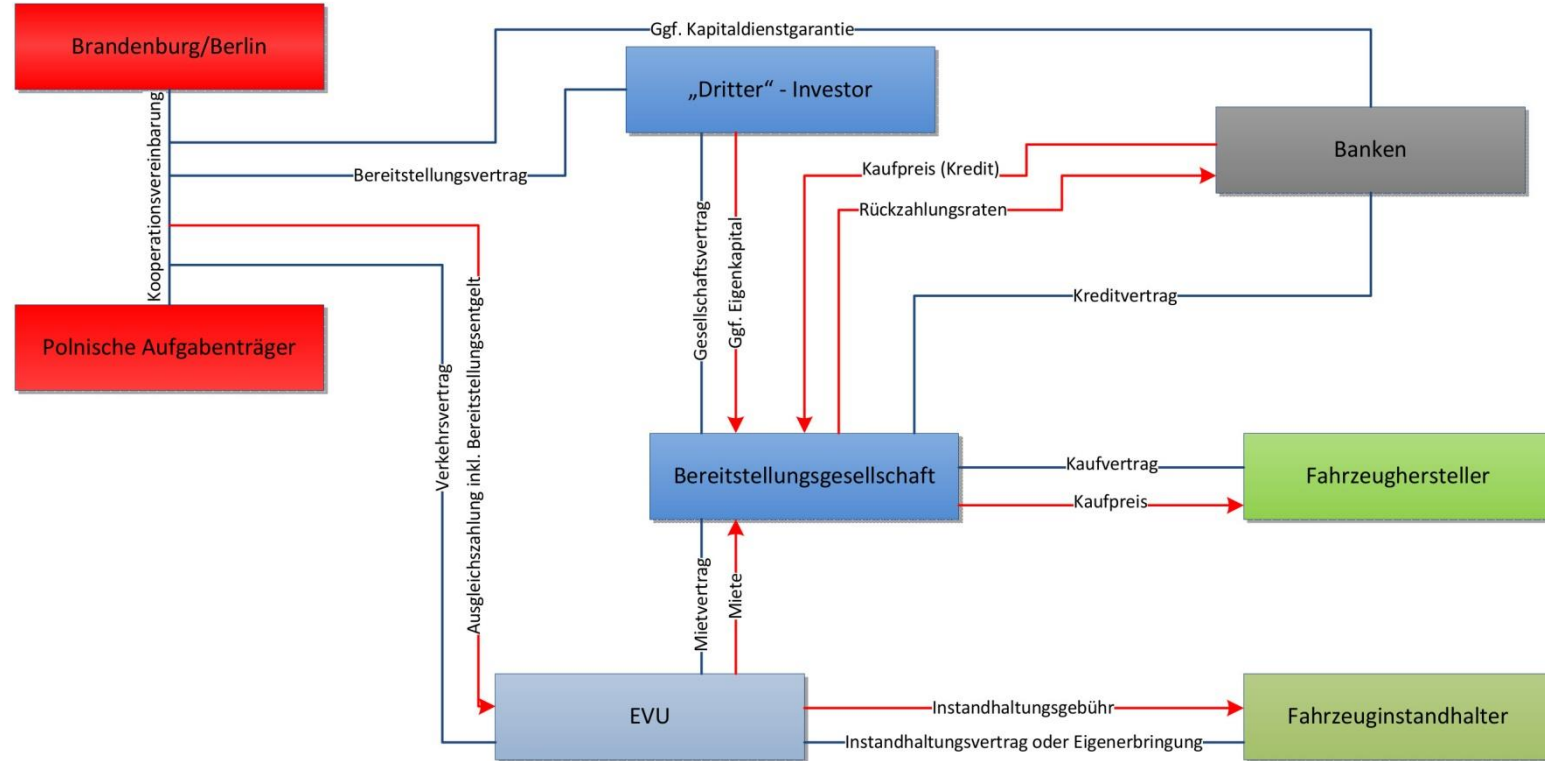

(c) ETC Transport Consultants GmbH

COORDINATED DESIGN AND JOINT FUNDING OF OFFERS

- According to different scenarios and time horizons, up to 30 multi-system electric multiple-units might be needed until 2030
- New possibilities for attractive cross-border offers, including offers between Berlin, Poznań and Warsaw

Abschnitt / Odcinek	Angebot / Oferta				Fahrzeugbedarf / Liczby pojazdów				Fahrzeug / Tabor	
	2023		2030		2023		2030			
	Min	Max	Min	Max	Min	Max	Min	Max		
Angermünde - Szczecin	RB: 4h	RB: 2h	RB: 2h	RB: 2h	1	1	1	1	EMU-3/EMU-5	
Berlin Hbf - Szczecin	RE: 4h	RE/IC: 2h	RE/IC: 2h	RE/IC: 1h	1	2	2	4	EMU-5	
Szczecin - Świnoujście	-	RE: 2 ZP	RE: 2 ZP	RE: 4h	-	1	1	1	EMU-3/EMU-5	
Szczecin - Gdańsk	-	IC: 2 ZP	IC: 2 ZP	IC: 4h	-	2	2	2	EMU-5	
Berlin - Warszawa	BWE: 2-4h	ED 250: 4h	ED 250: 4h	ED 250:2 h	-	-	-	-	-	
Berlin – Poznań	RE: 2 ZP	RE/IC: 4h	RE/IC: 4h	RE/IC:2 h	1	2	2	3	EMU-5	
Berlin – Wrocław	IC/RE: 1 ZP	IC: 2 ZP	IC: 2 ZP	IC: 4h	1	2	2	3	EMU-5	
Berlin – Wrocław	IC/RE: 2 ZP	IC: 4h	IC: 4h	IC: 4h	2	3	3	3	EMU-5	
Dresden – Wrocław	-	-	IC/RE: 4h	IC/RE: 2h	0	0	2	4	EMU-5	
(c) ETC Transport Consultants GmbH					Umläufe		6	13	15	21
					Reserve		2	2	3	3
					Gesamt		8	15	18	24
Zusatzbedarf/Risiken (Fpl-Zwänge)										
					RE8 BER		1	1	1	1
					RE8 (IC)		1	1	1	1
					BlN - Poz		0	1	1	1
					BLN - ZIG - WRO		0	0	0	1
					BLN - CB - WRO		0	1	1	1
					Max		10	19	22	29

COORDINATED DESIGN AND JOINT FUNDING OF OFFERS

- Possible cross-border offers with a pool of 20 railcars
- Frequency of offers:
 - thick line: 2 h
 - thin line: 4 h
 - dashed line: single trains

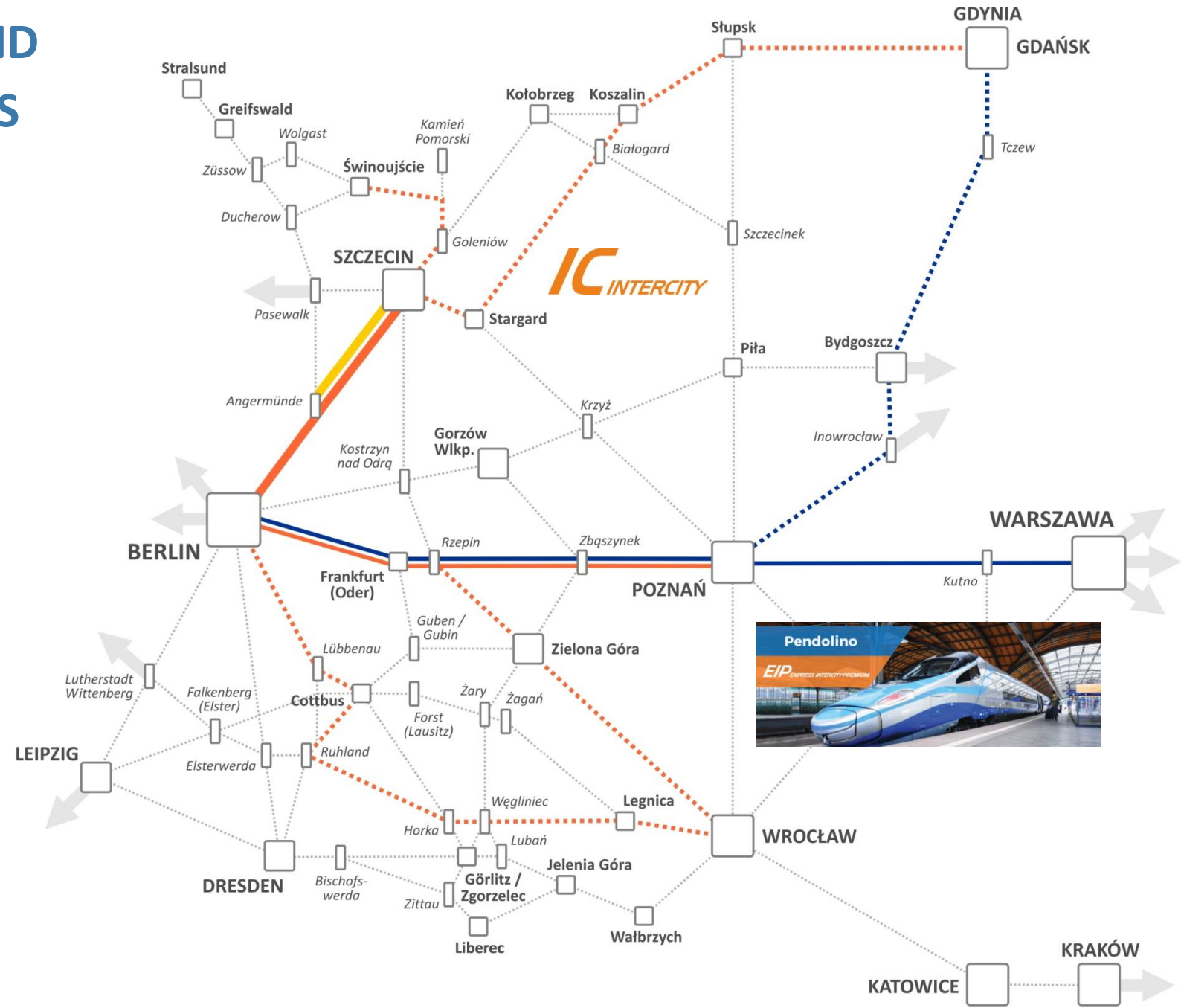

COORDINATED DESIGN AND JOINT FUNDING OF OFFERS

- Possible cross-border offers with a pool of 30 railcars
- Frequency of offers:
 - thick line: 2 h
 - thin line: 4 h
 - dashed line: single trains

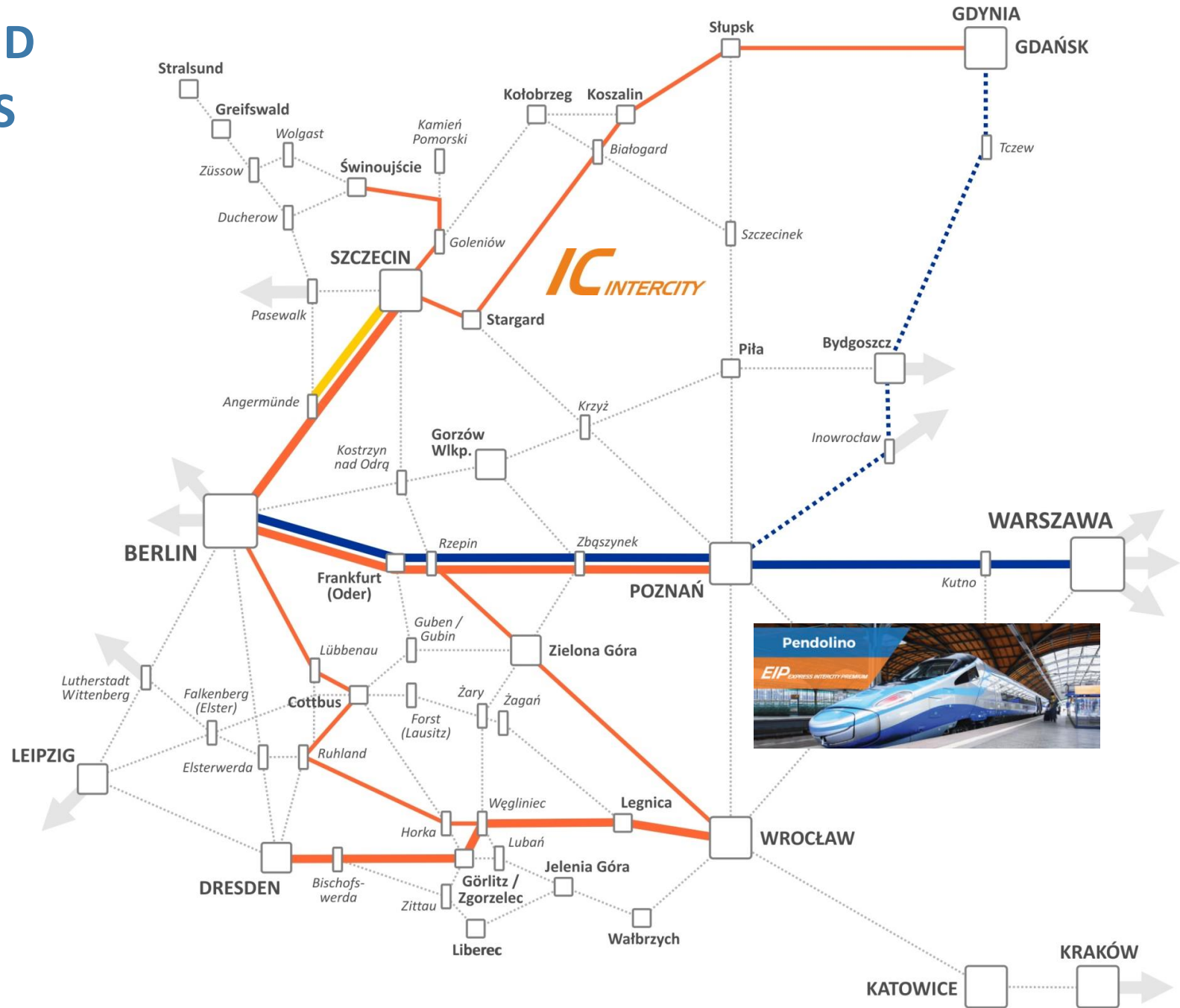

CONCLUSIONS

- Continuous upgrade of infrastructure along the Berlin – Poznań – Warsaw – Białystok Commuting Growth Corridor
- Promising developments in urban nodes, leading to more capacity for regional and urban transport
- Need for joint design of offers, leading to the definition of needs for modern and comfortable cross-border rolling stock
- Key challenges:
 - Identification of commercial long-distance offers, which might be operated without subsidy
 - Joint financing of non-commercial long-distance offers through combination of public funds for the contracting of subsidised long-distance transport (PL) and regional transport (DE)
 - Flexible provision of modern and comfortable cross-border rolling stock to operators of long-distance and regional transport



Prepared for:

Senate Department
for the Environment, Transport
and Climate Protection



by:

 **INFRASTRUKTUR & UMWELT**
Professor Böhm und Partner

Julius-Reiber-Straße 17
D-64293 Darmstadt
Telefon +49 (0) 61 51/81 30-0
Telefax +49 (0) 61 51/81 30-20

Niederlassung Potsdam

Gregor-Mendel-Straße 9
D-14469 Potsdam
Telefon +49 (0) 3 31/5 05 81-0
Telefax +49 (0) 3 31/5 05 81-20

E-Mail: mail@iu-info.de
Internet: www.iu-info.de

November 2019



EUROPEAN UNION

EUROPEAN
REGIONAL
DEVELOPMENT
FUND