



## Integrated and Sustainable Transport in Efficient Network - ISTEN

### DT1.3.6 - ISTEN Toolbox

WP no. and title	WPT1 - Activity T1.3 - Transnational Cooperation Network
WP leader	UNIMED
Responsible Author(s)	Domenico Gattuso
Contributor(s)	Gian Carla Cassone
Planned delivery date	November 2018
Actual delivery date	December 2019
Reporting period	RP 4.1

Dissemination Level		
PU	Public	X
PP	Restricted to other program participants (including the Commission Services)	
RE	Restricted to a group specified by the consortium (including the Commission Services)	
CO	Confidential, only for members of the consortium (including the Commission Services)	

*This document has been produced with the financial assistance of the European Union. The content of the document is the sole responsibility of UNIMED and can under no circumstances be regarded as reflecting the position of the European Union and/or ADRION programme authorities.*

## Document information

### Abstract

The document aims to provide a methodology, guidelines and criteria for defining the technical, operational and technological conditions that make the port and its hinterland an efficient hub.

### Keywords

methodology, guidelines, criteria, port, hinterland, efficient hub

### Authors

<b>Editor(s)</b>	Gian Carla Cassone
<b>Contributors</b>	Gian Carla Cassone Domenico Gattuso
<b>Peer Reviewers</b>	Domenico Gattuso

### Document history

Version	Date	Reviewed paragraphs	Short description
01	20.03.2019	All	First draft
02	05.04.2019	All	Second draft
03	09.12.2019	All	Final Version

\* Abbreviations of editor/contributor name

## Table of contents

1	INTRODUCTION .....	6
2	PORT-HINTERLAND CONCEPT .....	7
2.1	Methods for identifying a port's hinterland .....	10
2.2	Port-hinterland connectivity.....	13
2.3	Port-hinterland indicators.....	17
2.3.1	Port system .....	21
2.3.2	Port-hinterland connections.....	23
2.4	Port-hinterland problems .....	26
3	INTEGRATED PORT-HINTERLAND HUB CRITERIA.....	29
3.1	Infrastructures .....	30
3.2	Operations.....	31
3.3	Market.....	33
3.4	Innovation .....	34
3.4.1	Monitoring.....	35
3.4.2	Information flows management.....	38
3.4.3	Road traffic management.....	39
3.4.4	Automation .....	40
3.5	Institutions .....	47
4	METHODOLOGY FOR INTEGRATED PORT-HINTERLAND HUB.....	48
4.1	Phase 1: Local Analysis .....	49
4.2	Phase 2: Local Action Plan .....	50
4.2.1	Identification and characterization of actions.....	51
4.2.2	Evaluation of actions .....	52
5	CONCLUSIONS.....	54
	BIBLIOGRAPHY .....	55

## List of figures

<i>Figure 1: Port-hinterland concept</i> .....	7
<i>Figure 2: Continuous and discontinuous hinterland</i> .....	8
<i>Figure 3: Graphic representation of transport cost</i> .....	11
<i>Figure 4: Connection between O and D using different transport modes</i> .....	12
<i>Figure 5: Graphical representation of road transport and combined transport costs</i> .....	12
<i>Figure 6: Equitable cost curves</i> .....	13
<i>Figure 7: Dimensions of trade connectivity</i> .....	14
<i>Figure 8: Hinterland setting and major economic regions</i> .....	15
<i>Figure 9: Typology of port connectivity</i> .....	16
<i>Figure 10: Railway hinterland chain</i> .....	17
<i>Figure 11: Truck hinterland chain</i> .....	17
<i>Figure 12: Port-hinterland performance continuous</i> .....	18
<i>Figure 13: Scheme to evaluate performance of port-hinterland integrated hub</i> .....	20
<i>Figure 14: Levels of analysis</i> .....	30
<i>Figure 15: Cost-distance diagram</i> .....	33
<i>Figure 16: MONI.C.A. Platform</i> .....	36
<i>Figure 17: MONI.C.A. Structure</i> .....	37
<i>Figure 18: PCS advantages in information flows</i> .....	38
<i>Figure 19: Global Port Community System</i> .....	39
<i>Figure 20: Automation levels</i> .....	40
<i>Figure 21: Automated Guided Vehicle in Rotterdam port</i> .....	41
<i>Figure 22: Intelligent Autonomous Vehicle</i> .....	41
<i>Figure 23: Automated Straddle Carrier</i> .....	42
<i>Figure 24: Automated Transtainer</i> .....	42
<i>Figure 25: Potential changes resulting from the use of automatic trucks</i> .....	43
<i>Figure 26: Automated railway transport</i> .....	44
<i>Figure 27: Benefit of FlexCargoRail</i> .....	45
<i>Figure 28: Methodological approach</i> .....	48
<i>Figure 29: CANVAS Approach</i> .....	51

## List of tables

<i>Table 1: Sub-component of port hinterland</i> .....	9
<i>Table 2: Interest in a port</i> .....	19
<i>Table 3: Resources measures</i> .....	21
<i>Table 4: Examples of performance indicators</i> .....	22
<i>Table 5: Examples of risk type and connected adverse events</i> .....	53

## List of abbreviations and definitions

GDP - Gross Domestic Product

ICT - Information Communication Technologies

ADRION - ADRIatic IONian

TEN-T - Trans-European Networks - Transport

Ro-Ro - Roll-on Roll-off

SEZ - Special Economic Zone

MONI.C.A. - MONItoring & Control Application

PCS - Port Community System

AGV - Automated Guided Vehicle

IAV - Intelligent Autonomous Vehicle

ASC - Automated Straddle Carrier

ATT - Automated Transtainer

LCC - Life Cycle Costing

# 1 INTRODUCTION

The hinterland is a crucial part of the port composition. Most ports have a certain percentage of transit gateways, i.e. the containers are unloaded from the container ship to the yard, therefore through the gate they are conveyed towards the hinterland by land transport vehicles (truck and/or train). In this sense, transport in the hinterland is a fundamental component for ports. In their research, Horst and De Langen (2008) stressed the need to analyse inland transport systems because inland transport costs are, in general, higher than maritime costs. Furthermore, the problems of congestion and bottlenecks, in the door-to-door service and in the handling of rails, barges and trucks, take place in the hinterland networks. The development of any container port and its expansion depend on good transport for the hinterland, for which sufficient provisions should be prepared for road and rail capacity to help the terminal operate with high added value services. Many authors have expounded the topic of hinterland transport; some reasoned that the liner shipping challenge has shifted from the sea to ports and then to the hinterlands (Guthed, 2005; Notteboom, 2002).

Since the late 1990s ports are no longer seen as a kind of special places but as elements in supply chains/value chains. This new paradigm of 'ports as elements in value-driven chain systems' stresses that you can only understand a port if you take into account its place and function in the supply chain, i.e. a port is a node in a network that connects different production and/or consumer locations in different regions (Vanoutrive, 2011). Given the strong linkages between ports and their hinterlands, port throughput is often modelled as a function of the economic situation in the hinterland using GDP or trade figures.

The Deliverable consists of three chapters in addition to the introduction and conclusions. The concept of port hinterland is defined and analysed in chapter 2. Specifically, the question related to the determination of the hinterland dimensions is discussed and the methods useful for defining a hinterland and its boundaries are analysed. The characteristics relating to the connections between the port and its hinterland are also analysed and a series of specific indicators are proposed for the evaluation of the integrated port-hinterland system performance. Finally, some problems related to port-hinterland connectivity are analysed. Chapter 3 illustrates the main characteristics of an integrated port-hinterland hub and a series of infrastructural, operational, market, innovation and institutional indications are proposed to concretize the idea of an integrated port-hinterland hub. Finally, a methodological approach for the structuring of a procedure aimed at the realization of an integrated port-hinterland hub is proposed in chapter 4.

## 2 PORT-HINTERLAND CONCEPT

The port hinterland is one of the most important concepts in transport geography. In the sector literature there are different definitions that are very different from one another. Some authors define the hinterland as a land space on which a port sells its services (Slack, 1993; van Klink and van den Berg, 1998) and interacts with its customers or the market area served by a port and from where a port takes its load; others, define the hinterland as the area in which a port has a monopolistic position or area of origin and destination of a port, i.e. the inner region provided by a port (Fageda, 2005).

In general some ports have a hinterland that extends over vast areas, while other ports will have a smaller hinterland in relation to the characteristics of the port and the reference market. During the last few decades the role and functions ports and the services they provide have undergone significant changes, with greater emphasis being placed on port hinterland development. Today, with the development and affirmation of intermodality, several ports share the same hinterland, whose boundaries depend on the development of intermodal transport corridors and not on the exclusive market areas of each port. This creates a direct competition between ports very far from each other.

Figure 1 shows the port-hinterland concept of Rodrigue (Rodrigue, 2005). The port hinterlands are composed of two kinds of hinterland, the main hinterland and competition margin hinterland:

- the main hinterland (or prisoner) refers to the market area for which a terminal is the closest or easiest to access. It is assumed that most traffic will pass through the terminal, due to proximity and lack of competitive alternatives;
- the competitive hinterland (or competitive edge because it is commonly on the edge of the fundamental hinterland) is used to describe the market areas in which the terminal must compete more closely with the others for the companies.

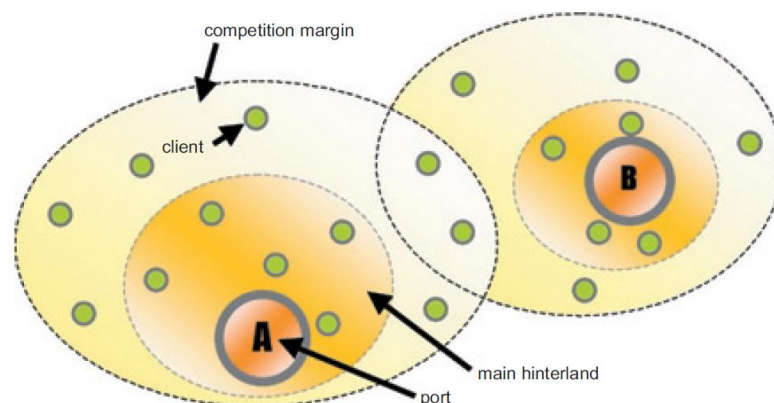

Figure 1: Port-hinterland concept  
Source: Rodrigue, 2005

So it is possible to affirm that the hinterland is a terrestrial space on which a transport terminal, like a port, sells its services and interacts with its users. It represents the regional market share that a terminal has compared to a series of other terminals that serve a region. It brings together all the customers directly connected to the terminal and the land areas from which it draws and distributes traffic. The terminal, depending on its nature, acts as a place of convergence for traffic coming from roads, railways or by sea/river.

In the contemporary setting where inland transportation is getting more efficient, the fundamental hinterland is being challenged by intense port competition, implying that competition margins are expanding, particularly in areas where several ports are present.

The mobility provided by the container has greatly facilitated hinterland penetration, so that many ports compete over the same market areas. The notion of discrete hinterlands with well-defined boundaries is questionable since many hinterlands have become discontinuous, a process facilitated by the development of corridors and inland intermodal terminals (Figure 2).

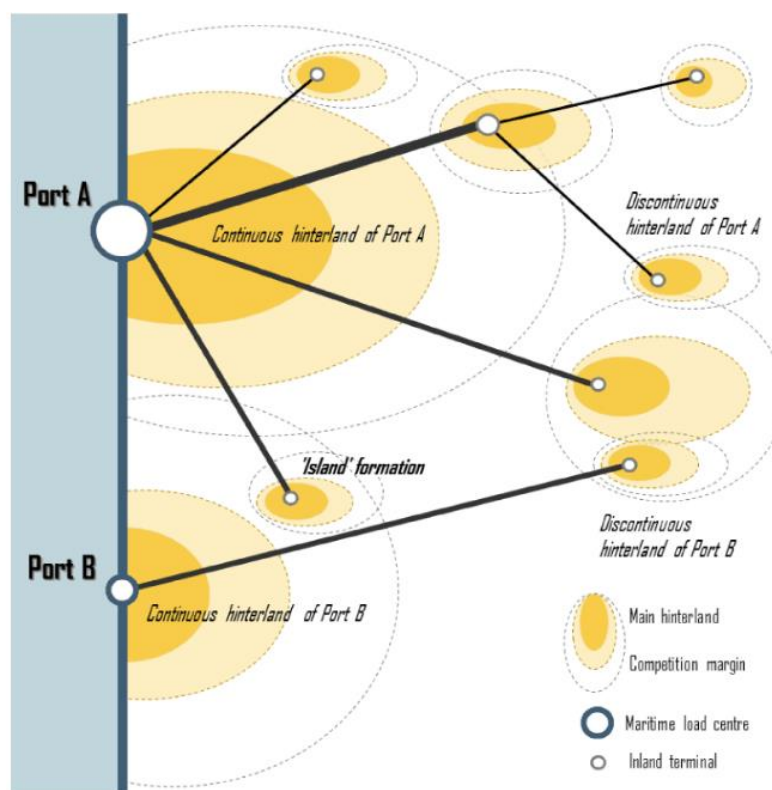

Figure 2: Continuous and discontinuous hinterland  
Source: Rodrigue, 2005

The direct hinterland of a port is continuous. The more distant hinterland features tend to be discontinuous in nature, since the density of hinterland origins or destination of port cargo is lower and because of the accessibility effect of transport corridors and inland terminals. “Islands” in the distant hinterland are created in which the load centre achieves a comparative cost and service advantage vis-à-vis rival seaports. This observation increases competition among ports of the same port system as the competitive margins of hinterlands become increasingly blurred.



Rodrigue and Notteboom (2007) proposed a new partition of the hinterland in relation to the transport system and to the connections that develop between the port and its hinterland. According to this logic it is possible to identify three basic sub-components of a hinterland: the macro-economic, physical and logistical hinterland. The macro-economic hinterland tries to identify which factors are shaping transport demand, particularly in a global setting. The physical hinterland considers the nature and extent of the transport supply, both from a modal and intermodal perspective. Finally, the logistical hinterland is concerned by the organization of flows as they reconcile transport demand and supply. Although the rationale behind these components appears simple, the shape they take is subject to complex spatial and functional structures. Table 1 summarizes the main characteristics of the three sub-components of a hinterland in terms of concept, elements, attributes and challenges.

*Table 1: Sub-component of hinterland*

Concept	Hinterland		
	Macro-economic	Physical	Logistical
Concept	Transport Demand	Transport Supply	Flows
Element	Logistical sites as part of Global Commodity Chains	<ul style="list-style-type: none"> <li>• Transport links</li> <li>• Terminals</li> </ul>	<ul style="list-style-type: none"> <li>• Modes</li> <li>• Timing</li> <li>• Punctuality</li> <li>• Frequency</li> </ul>
Attributes	<ul style="list-style-type: none"> <li>• Interest rates</li> <li>• Exchange rates</li> <li>• Prices</li> <li>• Savings</li> <li>• Production</li> <li>• Debt</li> </ul>	<ul style="list-style-type: none"> <li>• Capacity</li> <li>• Corridors</li> <li>• Terminals</li> <li>• Physical assets (fixed and mobile)</li> </ul>	<ul style="list-style-type: none"> <li>• Added value</li> <li>• Tons km</li> <li>• TEU</li> <li>• Added value</li> <li>• ICT</li> </ul>
Challenge	International division of production and consumption	Additional capacity (modal and intermodal)	Supply chain management

*(Source: Rodrigue and Notteboom, 2007)*

The three sub-components are highly interrelated: changes in one of the attributes will have a ripple effect on the macro-economic, physical and logistical hinterlands. For instance, exchange rate mechanisms can result in shifts in the trade balance between nations. Shipping lines might react by adjusting freight rates on both legs of the trade route, while logistics service providers might take decisions ranging from simple routing actions up to the complete reconfiguration of logistics networks. The changing trade balance might also have an impact on the capacity utilization of terminals, corridor infrastructures and physical assets.

## 2.1 Methods for identifying a port's hinterland

A theoretically complex question concerns the dimensions of the hinterland of a port, this due to a series of reasons:

- the hinterland can be evaluated only in relation to other ports since the hinterland is made up of all the areas in which a port has competitive generalized transport costs compared to competing ports;
- the hinterland differs by type of cargo, type of actor and destination abroad;
- the hinterland is not stable over time.

Some authors (Arvis et al., 2019; Meng et al., 2013; Hintjens, 2018) propose models for defining the hinterland of a port.

In particular, the model proposed by Arvis et alii (2019) provides a first indication of the hinterland of a port based on three variables: the road distance, the sea distance and the maritime connectivity with the reference region. This variable are evaluated in relation to the same distances for competing ports.

The model propose the evaluation of utility ( $U_{p,os,h}$ ) connected to the use of a port  $p$  for goods that must be transferred from region  $os$  (overseas region) to region  $h$  (hinterland region):

$$U_{p,os,h} = \alpha_0^{p,h} + \alpha_1 \cdot RD_{p,h} + \alpha_2 \cdot MD_{p,os} + \alpha_3 \cdot MC_p$$

where

- $RD_{p,h}$  is the road distance between port  $p$  and hinterland region  $h$ ,
- $MD_{p,os}$  is the maritime distance between port  $p$  and a certain world region,
- $MC_p$  is the maritime connectivity of port  $p$ ,
- $a_1, a_2$  and  $a_3$  are models' parameters;
- $\alpha_0^{p,h}$  is an error term.

Hintjens (2018), instead, defines the attractiveness of a port  $A$  ( $P_A$ ) from a hinterland connectivity as follows:

$$P_A = \frac{e^{-\alpha(HC_A + OC_A)}}{\sum_i e^{-\alpha(HC_i + OC_i)}}$$

$HC_A$  represents the connection cost to the hinterland,  $OC_A$  is the cost of foreland connection and the cost of port operations,  $HC_i$  e  $OC_i$  are the corresponding costs related to the port  $i$  in competition with the port  $A$ ,  $a$  is a parameter of the model.

To carry out the shipment it is possible to use a single-mode or multimodal transport; in the second case it is necessary to consider the costs of transshipment of the loading units. So  $HC_i$  is the sum of the cost of all used hinterland transport modes  $c^k$  and the transshipment costs  $c_t^{k-1}$  from each mode

$$HC_i = \sum_k c^k + c_t^{k-1}$$

It is possible to identify the hinterland that a port can potentially serve by using the theory of areas of influence.

This theory is an approach to the choice of location of a terminal and involves the analysis of the considered area to identify specific areas of influence within which there is convenience, in terms of lower overall transport cost, to use that particular terminal instead another.

In general, the procedure to identify the area of influence can be divided into three phases:

- development of decision-making processes that lead freight transport operators to choice of combined transport;
- identification of the savings obtainable from the choice of combined transport;
- comparison of the different alternatives through the use of multi-objective procedures.

The larger the area of influence, the greater the number of users potentially attracted by the node, in this case the port, through the use of certain modes of transport.

The representation of the area of influence can be performed graphically, adopting a procedure that involves the use of calculation methods and tools specific of analytical geometry. Assuming that the cost of transport can be expressed as a function of distance (calculated as the crow flies), but not of the direction of displacement, this cost can be represented in  $XYC$  space by a conical surface turned upside down with vertex  $O$  coinciding with the origin of displacement. Each point of the conical surface has as its position in the  $XY$  plane the destination ( $D_1$ ,  $D_2$ , etc.) and as coordinate  $C$  the entity of the transport cost ( $C_1$ ,  $C_2$ , etc.) of the connection from the origin  $O$  to the considered destination. The opening of the cone is inversely proportional to the kilometre cost of transport (Figure 3).

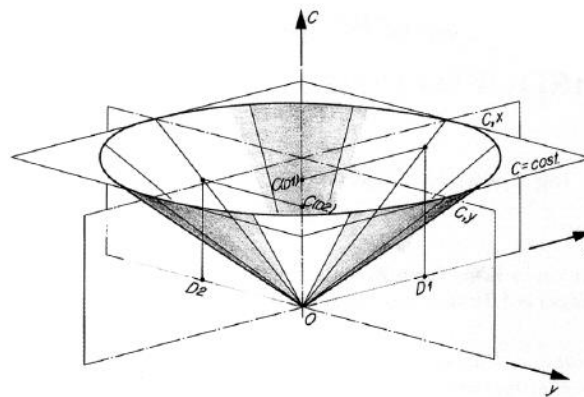

Figure 3: Graphic representation of transport cost

Suppose it is necessary to freight forwarding from  $O$  to  $D$  (Figure 4), assuming that the origin coincides with port  $A$  and that destination  $D$  can be reached using road transport or combined road-rail transport through the intermodal terminal  $B$ .

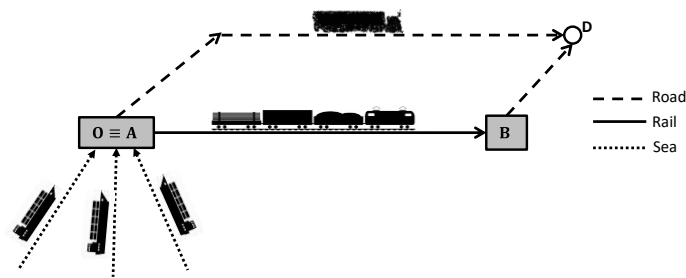

Figure 4: Connection between O and D using different transport modes

The situation can be represented graphically, assuming that the X axis coincides with the line joining the origin O with the terminal B (Figure 5).

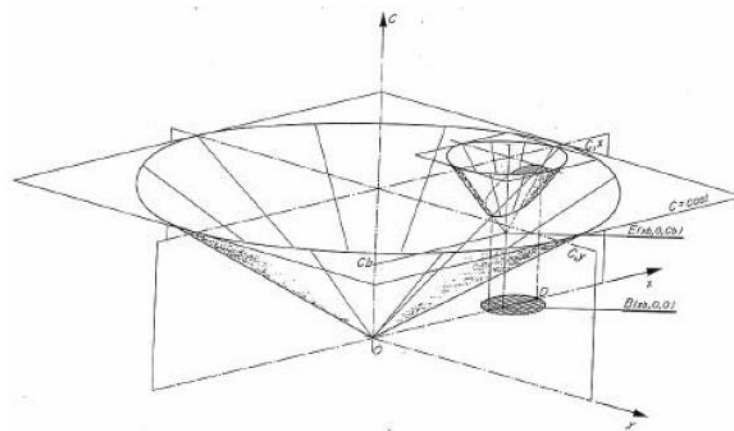

Figure 5: Graphical representation of road transport and combined transport costs

For road transport, the cost function is represented by the cone with vertex in O ( $O \equiv A$ ) and opening inversely proportional to the road kilometre cost (cone with the largest base in Figure 5).

The combined transport cost  $C_{C-OD}$  can be evaluated as sum of two components:

$$C_{C-AD} = C_{AB} + C_{BD}$$

where  $C_{AB}$  is the cost to go from the origin to terminal B, while  $C_{BD}$  is the cost to reach the final destination D from B. In particular the cost  $C_{OB}$  can be evaluated as:

$$C_{AB} = C_T + C_{AB}^*$$

where  $C_T$  is the cost of terminal operation in port A and in rail-road terminal B and  $C_{AB}^*$  is the cost associated with the railway distance.

If the position of the origin is fixed and the position of the destination D is variable, the combined transport cost function is represented, for the first term ( $C_{AB}$ ), by a vertical segment BE and for the second term ( $C_{BD}$ ) by a cone with vertex at point E opening inversely proportional to the road kilometre cost.

The intersection of the two conical figures forms closed or open surfaces whose projections in the displacement plane (XY) define the areas of convenience of the

combined transport with respect to the road transport for the connection of the port A with the destination D located in the port hinterland.

The destination nodes (industrial establishments, interchange centers, end customers, etc.) located within these areas of influence represent the range of users potentially attracted by combined transport.

A contribution to the synthetic evaluation can be provided by the representation in the displacement plane XY from the equitable cost curves (Figure 6).

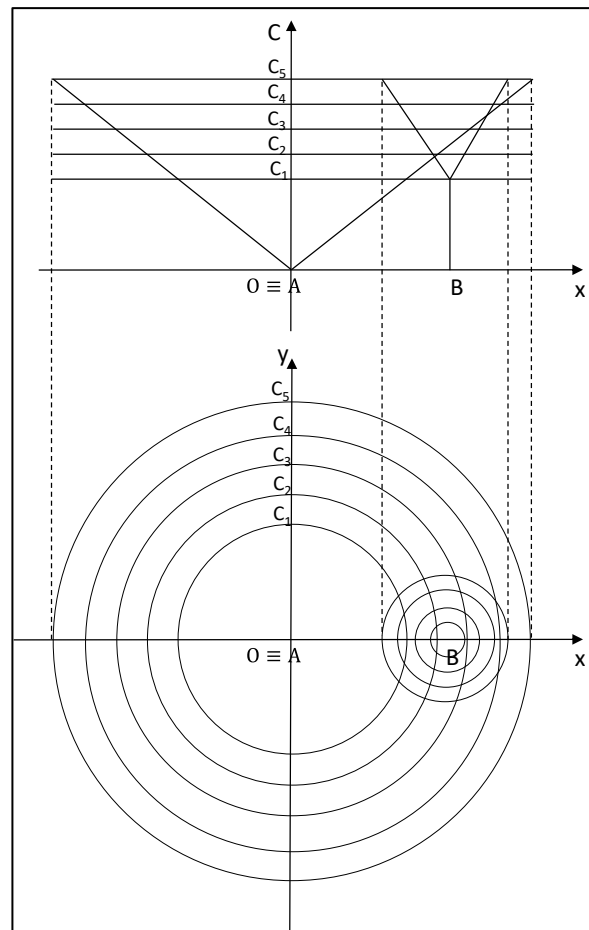

Figure 6: Equitable cost curves

## 2.2 Port-hinterland connectivity

Trade connectivity has three interdependent dimensions - maritime connectivity (also referred to as shipping networks), which refer to the structure and performance of shipping before the port; port efficiency, which refers to the performance of the port (or group of ports sharing the same hinterland); and hinterland connectivity, which involves multiple players and institutions contributing to economic development and exploiting maritime supply chains (Figure 7). All three dimensions explain how economies take advantage of their position in global and regional networks.

Maritime shipping has achieved remarkable economies of scale, underlining its ability to transport cargo over long distances and at a low unit cost. Economies of scale are

much more difficult to achieve over the hinterland and as traffic increases, transport networks near ports are getting increasingly congested. Hinterland transportation accounts for a dominant share (about 80%) of the transport cost while maritime shipping accounts for the remaining 20%. Therefore, hinterland transportation remains one of the most salient issues in long distance freight distribution.

Guaranteeing efficient connections (fast times and low costs) is essential to obtain effective port-hinterland integration.

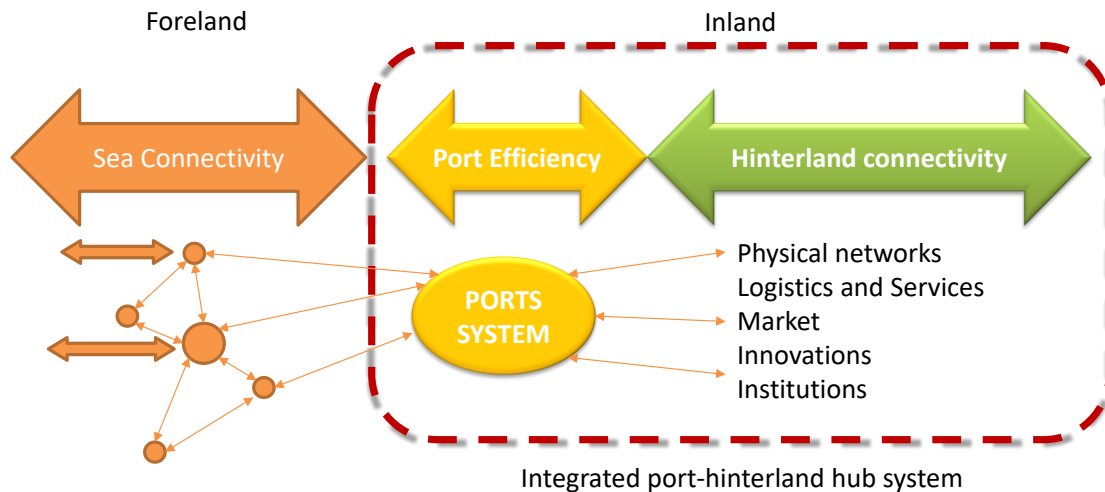

Figure 7: Dimensions of trade connectivity

The port-hinterland corridors can develop differently depending on the regional economic conditions and their intensity on the territory, on the importance of ports at regional level and on the characteristics of the freight corridors that guarantee the connection on a local, regional or national/transnational scale. For example, with reference to the three most important economic regions in the world (Figure 8) we can see that (Lee et alii, 2008):

- in North America, there is a high level of concentration of economic activities along the coastal areas with significant resource and manufacturing hinterlands. From coastal gateways long distance rail corridors, often taking the form of a landbridge, are servicing a continental hinterland. This hinterland is articulated by major transportation and industrial hubs such as Chicago;
- in Western Europe, the hinterland is the most intense in the interior, notably along the Rhine river system. This hinterland is accessed from coastal gateways, such as Rotterdam, Antwerp, Hamburg and Le Havre, through medium distance corridors involving a variety of combinations of road, barge and rail services. Almost all the major European capitals are interior cities located along rivers;
- in East and Southeast Asia, a significant share of the economic activity takes place along the coast, with a few high population density interior hinterlands, such as in China. Hinterland access is commonly problematic, linked to the fact that a large share of the accumulation of new economic activities has taken place in the vicinity of major gateways. There is thus a strong contrast

between coastal gateways equipped with modern (container) terminals and hinterlands usually poorly serviced by rail freight services.

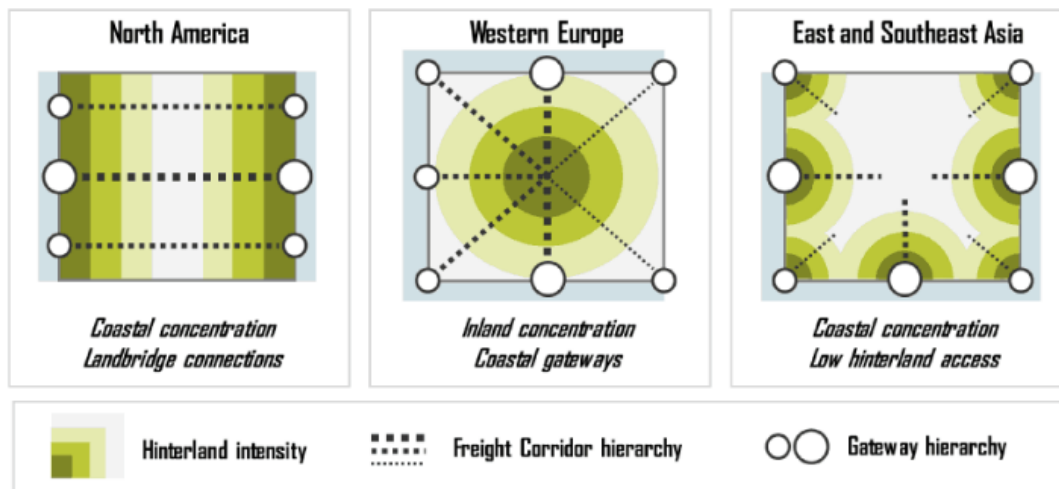

Figure 8: Hinterland setting and major economic regions

Source: Lee et alii, 2008

An inland centre is fulfilling three main types of connectivity (Arvis, 2019):

- **Gateway connectivity.** Represents the array of transport infrastructure and logistics services that enable an inland centre to be connected to a maritime trade gateway. This is particularly the case of rail and river barge services. Such connectivity has been actively pursued by ports that have developed hinterland accessibility strategies to expand their market and secure their traffic.
- **Regional connectivity.** Since an inland centre is based on servicing its regional market and resources, the strengthening of its regional connectivity is a core economic development strategy. This particularly involves road connectivity and logistics activities interacting between regional, national and global supply chains. This connectivity embeds the inland centre within its regional economic system.
- **Landbridge connectivity.** A form of connectivity that involves long distance inland corridors and where the inland centre acts as a connector between inland systems of circulation. This form of long distance connectivity almost exclusively covers rail transportation.

The development of a port depends on the connectivity that the same has both sea side and land side. The growth of one or both connectivity sizes leads to an increase in traffic. In the figure 9, for example, cell A represents a typical load-based port, with a brief connection to the hinterland (indicated by the dotted line on the left side of the cell) and only secondary maritime services to other ports, some of which are feeder services to hub ports. This type of port represents many ports that have a long history based on serving only the city and the metropolitan area in which they are located. Path A → B2 → C3 shows a strategy for developing connections at the local level focused exclusively on maritime services (A - direct and feeder services; B2 - addition of transshipment services; C3 addition of own feeder and transshipment services). Instead, the path A → B1 → C1 shows a development path focused exclusively on the connections with the hinterland passing from a local scale to a national /



transnational one. Type E can be considered the last stage of development for any port, but many factors come into play which can, after reaching a critical mass, cause loss of connectivity on the inland or sea side (such as congestion, handling costs, lack of space, competition and port selection).

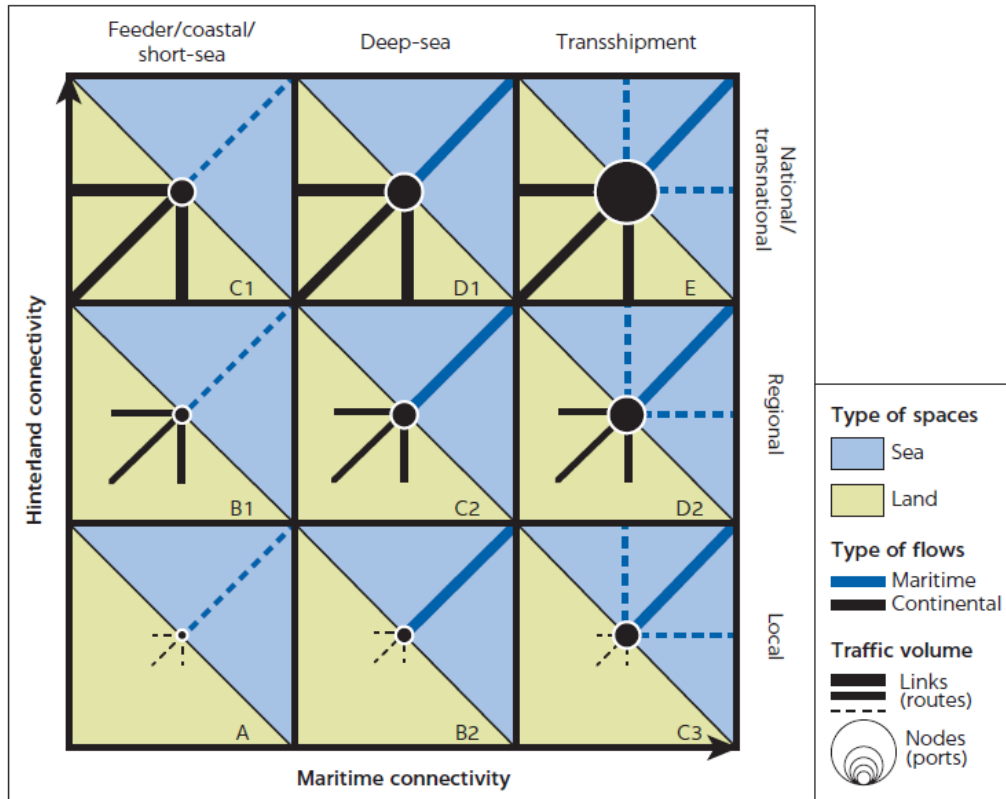

Figure 9: Typology of port connectivity  
Source: Arvis et alii, 2019

Setting the attention on port-hinterland connectivity, it should be noted that it involves numerous actors; in fact, apart from the private actors who provide transport and terminal services, several public actors are involved, such as customs, port authority, inspection services, infrastructure providers. Furthermore, port-hinterland connectivity does not only concern physical flows, but also information flows.

The structure of the hinterland chain is diversified in relation to the type of intermodal transport adopted for connections with the hinterland. Figures 10 and 11 show an example of how physical and information flows develop within a railway hinterland chain and a truck hinterland chain (van der Horst, 2016).



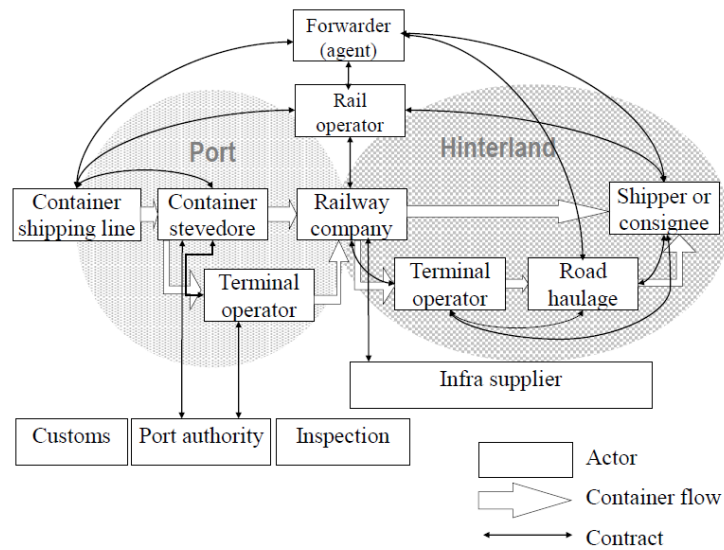

Figure 10: Railway hinterland chain  
Source: van der Horst, 2016

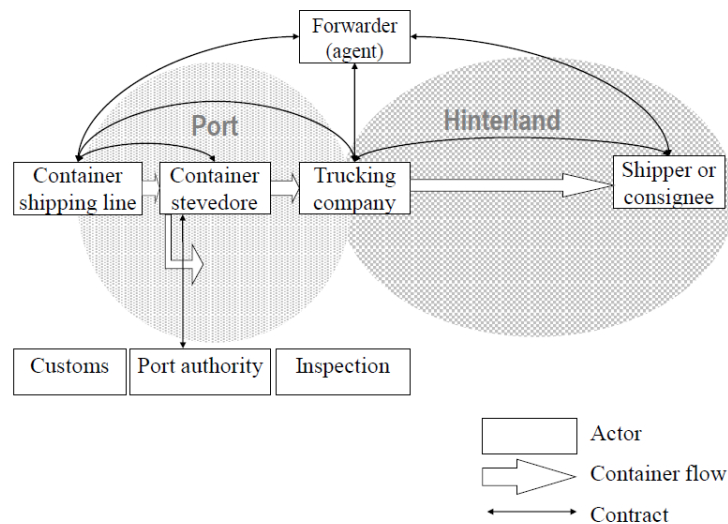

Figure 11: Truck hinterland chain  
Source: van der Horst, 2016

### 2.3 Port-hinterland indicators

The efficiency of an integrated port-hinterland hub system is the last link in the value chain that also includes the performance of the port node and the maritime connections with the foreland (Figure 12). These dimensions are interrelated since inefficiencies in one dimension are likely to impact the others. For instance, issues in terminal operations are most likely to negatively impact maritime and hinterland operations with delays.

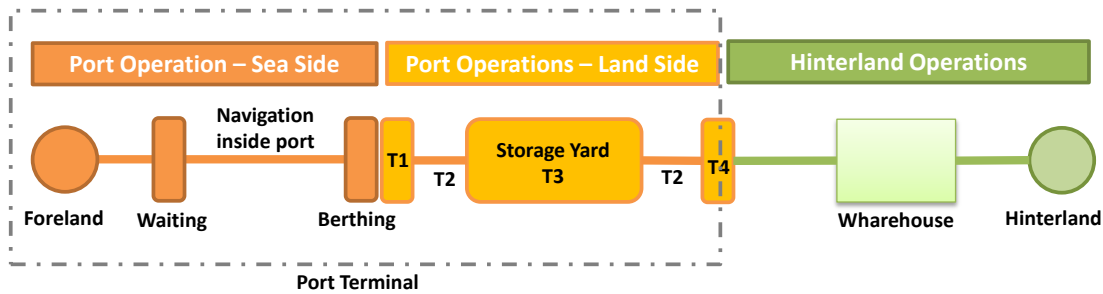

Figure 12: Port-hinterland performance continuous

The efficiency of maritime access (port operations - sea side) is a component of the port's performance, which includes waiting for an available mooring space, navigation inside the port and mooring. Navigation within the port may require towing and piloting activities (this depends on the site and its configuration) through access channels and turning basins. Long access times can be the result of a lack of mooring places and of terminal productivity problems.

Land-side operations at the port include a series of related activities with specific performances that influence the operation and productivity of the entire node:

- crane performance (T1) is a common bottleneck in terms of the number of crane movements per hour and the number of cranes available to serve a ship. For shipping companies, this is a crucial factor as it depends on the time that ships remain in port;
- the handling system (T2) is crucial in defining the performance of the port. The best performance of this system corresponds to greater efficiency in handling containers between the different areas of the terminal (quay-yard, yard-area truck; yard-train area for indirect transfers). For terminals equipped with on-dock rail services, the performance of the rail loading / unloading equipment is an important component of the terminal's performance;
- the storage yard management and organization determines storage capacity (T3);
- the gate services (T4) concern the efficiency of the activities related to the processing of documents and security inspections.

Hinterland operations can involve all transportation and distribution activities serving port customers. However, for practical purposes, to evaluate the efficiency of these operations, reference is generally made to internal operations adjacent to the port area. The key factor in background operations is the capacity of networks in areas adjacent to the port.

While terminal operations are usually given to private operators, port authorities tend to have a direct oversight of maritime operations and several elements of hinterland operations. Although community is not directly involved in port operations it commonly provides and maintains crucial infrastructure connecting the port with its hinterland. It also bears many of the externalities of port operations, namely local congestion, emissions. Therefore, the port authority and the community are important stakeholders in the port-hinterland performance continuum.

The methods to analyse the performance of the port-hinterland system can be classified in two different ways:

- parametric methods (stochastic frontiers and econometric models);
- non-parametric methods (data envelopment analysis and analysis through indicators).

The “analysis through indicators” is based on a set of indicators. It is important the identification of the indicators based on smart criteria in order to avoid redundancy, to assure clear means, to calculate them easily. The most current indicators in the field literature are efficiency and effectiveness. Ordinarily, the term efficiency refers to the ability to produce the desired output with the minimum input level or the maximum output for a given input (the best use of resources). Effectiveness is a measure of the capability to achieve predetermined targets that have to concern service consumption.

It is possible to define three sets of indicators related to different points of view: user, operators, community (Table 2).

In particular, for the service provider’s point of view it is essential to define efficiency indicators, to describe the services and processes carried out. From the user’s perspective, it is important to define a set of efficiency, quality and reliability indicators that describe the service level of the node and its connections with the hinterland also in terms of time and costs. Finally, for a community point of view it is necessary to define indicators able to assess the economic, social and environmental sustainability of the integrated port-hinterland system (indicators of efficiency, quality, etc.).

*Table 2: Interest in a port*

	Actors	Objectives	Type of indicator	
Provider	<ul style="list-style-type: none"> <li>– Terminal owner/manager</li> <li>– Terminal operators</li> <li>– Handling companies</li> </ul>	– Maximize system capacity	<ul style="list-style-type: none"> <li>– Efficiency</li> <li>– Effectiveness</li> </ul>	
		– Maximize system productivity		
		– Minimize management costs		
		– Service efficiency		
		– Service effectiveness		
User	<ul style="list-style-type: none"> <li>– Transportation operators</li> <li>– Freight forwarder</li> <li>– MTO</li> <li>– Shipping line companies &amp; Shipping Agents</li> <li>– 3PL &amp; Container depot companies</li> <li>– Export and Import companies (broker)</li> <li>– Industries</li> <li>– Wholesaler</li> <li>– SMEs</li> </ul>	– Minimize freight charge	<ul style="list-style-type: none"> <li>– Efficiency</li> <li>– Level of service (Costs and times)</li> <li>– Service reliability</li> <li>– Quality</li> </ul>	
		– Reliability and service frequency		
		– Slot availability		
		– Optimum accessibility		
		– Intermodal transport		
		– Cargo safety		
		– Environmental impacts		<ul style="list-style-type: none"> <li>– Efficiency</li> <li>– Quality/Safety</li> <li>– Environmental Emissions</li> </ul>
		– Trade impacts		
		– Economic impacts		

Some classes of indicators are important for all actors within the port-hinterland logistics system. For example, service providers are interested in measurements of user service level, because the operator tries to satisfy demand in order to guarantee high-level and competitive services. Users in turn are interested in the efficiency of the system and therefore in its ability to respond to specific needs. The community also carefully observes the efficiency of the system as it depends on the ability to attract investments and to produce positive economic effects on the territory.

Figure 13 proposes an organic and ordered scheme for evaluating the performance of a port-hinterland integrated hub.

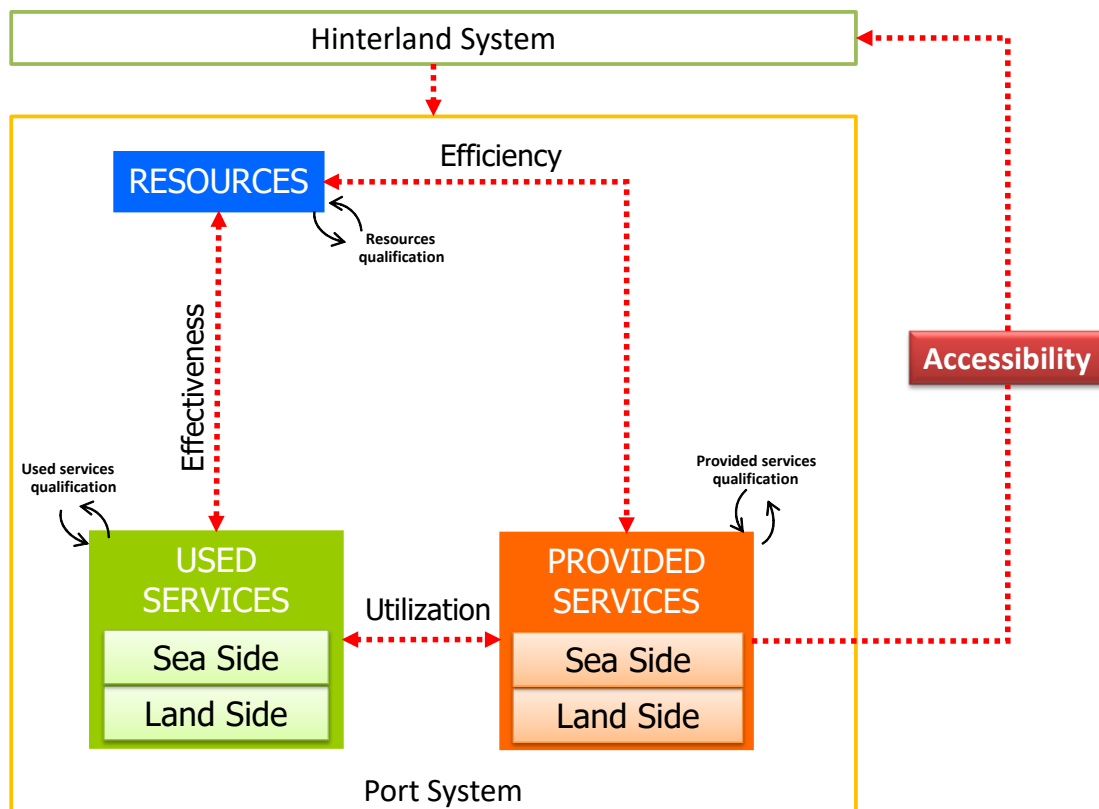

Figure 13: Scheme to evaluate performance of port-hinterland integrated hub

The scheme is derived by some studies Gattuso et alii (2009; 2019) applied to the public transport context. In order to define clearly a set of indicators useful to assess the performance of a complex port-hinterland system from the service provider's point of view, four groups of variables are identified: resources, used services, delivered services, planned services. The relationship between the measures grouped in the identified clusters allows to obtain the following 4 categories of indicators: efficiency (real and expected), effectiveness, utilization degree (real and expected), reliability. The scheme also shows three other classes of indicators called "qualification indicators" expressed as ratio between service (or resources) with a specific quality and the total of the corresponding services (or resources). On the other hand, accessibility represents a tool capable of expressing the level of connectivity between the port system and the surrounding region; therefore it can be considered a synthetic indicator for the evaluation of the organization and connection of the complex port-hinterland system characterized by the combination of geographical elements and anthropic activities.

### 2.3.1 Port system

To assess the performance of the port system, in the service provider's point of view, it is necessary to quantify three different aspects: system productivity; level of demand satisfaction; service reliability. The first aspect is evaluated by efficiency indicators (that describe relations among provided service and resources). The level of demand satisfaction is related to appropriate effectiveness indicators (in terms of a ratio between utilized services and resources spent to realize the same service) and utilization degree indicators (in terms of ratio between provided service and utilized service).

Resources can be differentiated in three categories: infrastructural resources, handling resources and human resources (Table 3).

Table 3: Resources measures

Category	Resource	Symbol	Unit of measure
Infrastructures	Terminal surface	$S$	$[m^2]$
	Yard surface	$S_y$	$[m^2]$
	Slots number	$N_s$	-
	Berths number	$N_b$	-
	Berth length	$L_b$	$[m]$
	Tracks number	$N_t$	-
	Track length	$L_t$	$[m]$
	Input/output road gates	$G_r$	-
Handling means	Quay cranes number	$N_{qc}$	-
	Yard means number <sup>(1)</sup>	$N_{Ey}$	-
Staff	Employees number	$A$	-
	Terminal operators number	$I_T$	-

<sup>(1)</sup> Yard equipment = straddle carrier, fork lift, reach stacker, multi-trailer

For a port container the typical cargo unit is the TEU (Twenty-foot Equivalent Unit); it is the standard measure of 1 reference container. Provided service can be measured in terms of: TEUs handling ( $N_{TEU}$ ) among different terminal areas, number of called and worked ships in a reference period ( $N_{ship}$ ), length of ships moored at the quay ( $L_{tship}$ ), number of trucks and trains charged/discharged in a reference period ( $N_{Truck}$ ,  $N_{Train}$ ); storage yard capacity ( $C_{y-max}$ ), potentiality of rail/truck area ( $P_{Truck}$ ,  $P_{Train}$ ).

Utilized services represents the demand, the quantity of freight moved through the port and making use of provided services in a reference unit of time. They can be defined in terms of: number of cargo units (TEU) handled, number of cargo units handled by ship/truck/train ( $N_{TEU}^{Ship}$ ,  $N_{TEU}^{Truck}$ ,  $N_{TEU}^{train}$ ), number of cargo units allocated in the yard at the same time (DTEU), number of ships called (SHIP), number of trucks and trains arrived (TIR, TRAIN).

Relating to the above-mentioned measures, it is possible to define the following categories of indicators:

- *efficiency*: provided services/resources;
- *effectiveness*: utilized services/resources;

- *utilization*: provided services/ utilized services;
- *reliability*: provided services/ planned services.

It is possible, consequently, to define a large set of performance indicators. In the table 4 some significant indicators are proposed.

Table 4: Examples of performance indicators

Class	Indicator	Definition	Unit of measure
Efficiency	Handling berth sea-side	$N^{ship} / N_b$	vessels/berth
		$L_{tship} / L_b * 100$	%
		$N^{ship} / N_{qc}$	vessels/crane
		$N^{ship} / A$	vessels/employee
	Handling berth land-side	$N_{TEU} / L_b$	handlings/berth m
		$N_{TEU} / N_b$	handlings/berth
		$N_{TEU} / N_{qc}$	handlings/crane
	Handling yard area	$N_{TEU} / S_p$	handlings/m <sup>2</sup>
		$N_{TEU} / N_s$	handlings/slot
		$N_{TEU} / A$	handlings/employee
		$N_{TEU} / N_{Ey}$	handling/equipment
	Handling train-side area	$N^{train} / L_t$	trains/berth m
		$N^{train} / N_t$	trains/track
		$N^{train} / A$	trains/employee
Handling truck-side area	$N^{truck} / G_r$	trucks/road gate	
	$N^{truck} / A$	trucks/employee	
Effectiveness	Demand berth	$TEU / L_b$	TEUs/berth m
		$TEU / N_b$	TEUs/berth
		$TEU / N_{qc}$	TEUs/crane
	Demand yard	$TEU / S_p$	TEUs/m <sup>2</sup>
		$TEU / N_s$	TEUs/slot
		$TEU / N_{Ey}$	TEUs/equipment
		$TEU / A$	TEUs/employee
	Demand train area	$N_{TEU}^{Ship} / L_t$	TEUs/berth m
		$N_{TEU}^{train} / N_t$	TEUs/track
	Demand truck area	$N_{TEU}^{Truck} / G_r$	TEUs/road gate
Utilization degree	Yard utilization	$D_{TEU} / C_{v-max} * 100$	%
	Truck area utilization	$TRUCK / P_{Truck} * 100$	%
	Train area utilization	$TRAIN / P_{Train} * 100$	%
Reliability	Reliability of berth	$N^{TEU} / N^{PTEU} * 100$	%
		$N^{ship} / N^{Pship} * 100$	%
	Reliability of truck area	$N^{truck} / N^{Ptruck} * 100$	%
	Reliability of train area	$N^{train} / N^{Ptrain} * 100$	%

In the user's perspective, the evaluation of a port's performance can be carried out by using the efficiency indicators described above, but also considering the port's service level in terms of crossing times and costs. In fact, the costs and times at the port node represent an important component of the total transport cost. These costs are dependent of the cargo moving length and significantly variable in relation to the modes of transport involved (sea-road, sea-railway) and any storage and handling carried out on goods in transit. Naturally, the costs are reduced by improving the operation and efficiency of the port, therefore the indicators of efficiency and level of service are interrelated.

In the perspective of the community, the indicators that express the efficiency and effectiveness of the port are very important; in fact, they determine economic impacts on the territory and new scenarios of market structure.

### 2.3.2 Port-hinterland connections

Accessibility indicators can be used to evaluate performance related to the connections between the port system and its hinterland. These indicators arise from the relationship between the service offered (land side) from the port system and the land use parameters (infrastructures, activities, etc.) of the hinterland.

The definitions of the accessibility term in the literature can be divided into four macro-groups in relation to the considered context: geographic, spatial, micro-economic interaction, space-temporal interaction.

Referring to the geographical context, accessibility is understood as a measure of the “ease” with which one site can be reached by another, measured as time or average travel cost. In a context of spatial interaction, accessibility can be used as a measure of the potential of social and economic interaction, function of the distribution of potential destinations, the ease of reaching each destination and the quality and character of the activities in each destination. At the micro-economic level, accessibility can be expressed in terms of social benefits associated with a specific territorial structure. On the time-space dimension, accessibility can be seen as the potential of interaction, taking into account the constraints (temporal, spatial, physiological, information) that can affect the choices of operators involved in the supply chain.

The conceptual differences emerging from the different accessibility definitions are reflected on the formulations that can refer to a single transport component, or to the land component such as the result of the spatial distribution of the different human activities, to join also the temporal distribution of land activities and gradually other constraints.

In the specialised literature related to the performance of a port-hinterland transport system, accessibility is rarely considered, but it represents a fundamental measure to express how much the port system is integrated in a territory and how much it is able to respond to the commercial needs of the territory. Accessibility measures express the relationship between the transport service offered and the port hinterland; three different types of indicators can be defined: land coverage; geographic accessibility.

In terms of land coverage, it is possible to express a series of topological indicators starting from the network graph. These indicators can be assessed at the node and at the network level.

Node-level indicators allow to evaluate the node connection degree; these indicators can be assessed considering the maritime connections (foreland) and the land connections (hinterland). It is possible to consider:

- Centrality Degree of a node, representing the number of direct connections starting from the node:



$$C_D(i) = \sum_j n_{ij}$$

where  $n_{ij}$  is the generic element of the adjacency matrix between nodes that is equal 1 if the nodes  $i$  and  $j$  are connected to each other by a link, 0 otherwise. the higher the value of this index, the more important a node is within a network since many connections converge on it.

- Eccentricity (or Koenig number) indicating the topological proximity of the network nodes; in the specific case of the port, the proximity of other significant inland terminals (hinterland) and / or ports (foreland):

$$E(i) = \max_{j \in X} d_{ij}$$

with  $i, j$  nodes of the network,  $X$  set of nodes connected to  $i$ ,  $d_{ij}$  topological distance between nodes  $i$  and  $j$ . Low values indicate a poorly connected network.

- Shimbel Index which represents a measure of the accessibility assessable as the sum of the length of all the shortest paths that connect the node to the other nodes of the graph:

$$SI_i = \sum_j dm_{ij}$$

with  $dm_{ij}$  minimum distance between nodes  $i$  and  $j$ .

- Betweenness centrality (or shorter path betweenness) which represents the number of times a node is crossed by the shortest paths in the graph:

$$C_B(i) = \sum_{j>k} \frac{g_{jk}(i)}{g_{jk}}$$

where  $g_{jk}$  is the number of shorter paths that connect the nodes  $j$  and  $k$ ;  $g_{jk}(i)$  is the number of times node  $i$  is crossed by these paths.

At network level, some reference accessibility indices are the following:

- Density of the network, as measure of the territorial extension of a transport network in terms of connections length ( $L$ ) per land surface extension ( $S$ ). The higher it is, the more a network is developed:

$$K = L/S$$

- Gamma Index, indicating the degree of connection of the network to which the port node belongs and assessable as a ratio between the number of effective connections and the number of possible connections on the reference network:

$$GI = \frac{N_c}{[3 \cdot (n - 2)]}$$

$N_c$  being the number of connections and  $n$  the number of nodes in the graph; low values of the index indicate that the network is poorly connected, while higher values suggest a densely connected network therefore favourable to the development of an integrated port-hinterland system.

- Clustering coefficient explains extent to which the network is centralized:

$$CC_i = \frac{N_{pc}(i)}{N_p(i)}$$



where  $N_{pc}(i)$  is the number of pairs of neighbours of node  $i$  that are connected and  $N_p(i)$  is the number of pairs of neighbours of node  $i$ . Lower values suggest the presence of hub-and-spoke structures; higher values suggest a more homogenous configuration

- Average length of the shortest routes (or the average topological length) of all the shortest routes existing in the network:

$$L_G = \frac{\sum_{ij} d_{ij}}{[n \cdot (n - 1)]}$$

with  $n$  the number of nodes in the graph and  $d_{ij}$  the distance between nodes  $i$  e  $j$ ; this measure allows to evaluate the ease of circulation in the network: lower values suggest less deviations and longer efficient routes.

The most known geographic accessibility indicators rely on the cost functions associated with a transport network. Given a land system, subdivided into  $n$  zones, and the relative road network, the matrix of minimum paths can be considered the starting point for accessibility measures. The rows of this matrix correspond to the set of origin nodes and the columns to the set of destination nodes; the matrix elements, expression of the impedance function  $c_{ij}$ , constitute the indices of relative accessibility, that is the measure of the cost to overcome the spatial separation between each pair of nodes  $i$  and  $j$  on the land:

$$a_{ij} = c_{ij}$$

where  $c_{ij}$  can indicate the distance or travel time or the transportation cost from the zone  $i$  to the zone  $j$ .

The sum of the elements of the  $i$  line of the minimum path matrix provides the value of nodal accessibility relative to the zone  $i$ . It constitutes the minimum total impedance for the movements from the zone  $i$  to all the other zones, i.e. the integral accessibility index referring to the zone  $i$ , which expresses the connection of the zone  $i$  with the surrounding land (zones  $j$ ):

$$A_i = \sum_j a_{ij} \quad j \in J$$

where  $J$  represents the set of the destination zones of the trips.

Other indicators for assessing accessibility on a geographical basis are the following two:

- geographic accessibility:

$$G = \frac{1}{n \cdot (n - 1)} \sum_{i=1}^n \sum_{j=1}^n g_{ij}$$

- global standardised accessibility:

$$E = \frac{1}{n \cdot (n - 1)} \sum_{i=1}^n \sum_{j=1}^n t_{ij}$$

where  $n$  is the number of nodes in the reference land,  $g_{ij}$  is the distance of minimum path between  $i$  and  $j$ ,  $t_{ij}$  is the travel time along the minimum path between  $i$  and  $j$ .

The accessibility indicators seen above are functions only of the travel cost variable. In reality, experience shows that other factors contribute to determining the possibility to travel from the  $i$  zone to the  $j$  zone; these factors are linked to the system of local activities such as population, job opportunities, accommodation, factors that can act in defining the impedance function. Beyond the different theoretical formulations, an aggregate measure can be summarized with a single formulation:

$$A_i = \sum_j K_j^\beta \cdot \phi(c_{ij})$$

where:

- $A_i$  is the weighted accessibility for people living in zone  $i$  related to the zones  $j$  in a given region;
- $K_j$  is a measure of activities and services located in zone  $j$ ;
- $\beta$  is a calibration parameter;
- $\Phi(c_{ij})$  is an impedance function (Table 5), usually decreasing with the cost  $c_{ij}$ , which over the years has assumed different expressions, depending on the authors.

*Table 1: Impedance functions*

Source	Expression	Variables
Hansen (1959)	$\phi(c_{ij}) = c_{ij}^{-\beta}$	$c_{ij}$ distance between the zones $i$ and $j$
Wilson (1967)	$\phi(c_{ij}) = \exp[-(\beta_1 \cdot t_{ij} + \beta_2 \cdot c_{ij})]$	$t_{ij}$ time to reach the zone $j$ starting from the zone $i$ ; $c_{ij}$ cost to reach the zone $j$ starting from the zone $i$ ; $\beta_1$ e $\beta_2$ parameters of the model.
Ingram (1971)	$\phi(c_{ij}) = \exp(-d_{ij} / \gamma)$	$d_{ij}$ distance between the zones $i$ and $j$ ; $\gamma$ parameter of the model.

In all these expressions the problem is the attribution of values to the different parameters, because accessibility cannot be measured experimentally, i.e. the parameters cannot be calibrated on the basis of real observations.

## 2.4 Port-hinterland problems

Connectivity problems between the port and its hinterland must be assessed at different levels. It is necessary to evaluate the difficulties linked to the infrastructure system, to the supply chain operation that guarantees the connectivity between port and hinterland without underestimating the problems related to the market, innovation and the institutional framework.

Infrastructural problems affect the efficiency of hinterland penetration by creating material bottlenecks to the physical flow of goods between the port and its hinterland, and vice versa.

The operational problems concern above all the provided services, that are the transport, the transfer, the possible handling of the goods.

The lack of innovation often leads to a series of problems that affect the operation of the port and make relations with the hinterland more complicated. For example, some studies show that trucks that arrive at the port to unload and / or load goods often have inappropriate documents (Wada and Tsuchida, 2013; Motono et al., 2014): this causes an increase in congestion at road gates and an increase in truck service time.

Many of the problems relating to the connections between the port and the hinterland arise from the lack of coordination and cooperation between the actors in the logistic chain. In fact, a wide variety of stakeholders is engaged in hinterland transport, such as private companies, shipping lines, terminal operators, freight forwarders, clearing agents, hinterland transport providers e.g. trucking, rail, and barge companies, in addition to public authorities such as customs, port authorities, inspection services, and infrastructure managers.

Businesses often focus on internal issues and devote less effort to solving chain coordination problems as a whole. This attitude is more marked if the actors expect cooperation to be difficult to achieve.

Horst and De Langen (2008) stated that the development might be hampered by the lack of motivation and incentives for further cooperation, e.g. free-riding problems, information irregularity, and the requirement for contractual obligations, which stem from an imbalance between the costs and benefits and the lack of eagerness to invest. On a general level, the problems of coordination and cooperation concern:

- the inadequate exchange of information between the container shipping line, the terminal operator and the transport companies;
- the lack of commitment on the part of the companies that control the goods to guarantee the volumes for newly-built hinterland services; the introduction of a new hinterland service (e.g. a container shuttle) requires a basic volume. However, shippers and container shipping companies are often not willing to commit to new services, either for opportunism or concerns over the benefits for competitors;
- the planning of empty containers; coordination among the terminal, hinterland terminals and container shipping lines could reduce empty movements;
- the lack of coordination between hinterland transport companies and organizations such as customs and inspection services.

For example, looking at the railway sector and intermodal transport for port-hinterland connections it should be noted that the European rail freight market has been liberalized, resulting in the separation of infrastructure from the provision of services.

The assignment of railway tracks creates problems of coordination between the infrastructure manager and the railway companies. Coordination problems also occur in railway terminals in ports. Terminal operators elaborate a management plan of the facilities with time intervals for each train on the terminal. However, due to the lack of contractual ties between the operators of the railway terminals and the railway companies, it is difficult to obtain the coordination level needed for a terminal planning to be able to maximize the chain's efficiency.

Moreover, the exchange of traction (for example, through a group of locomotives) would increase the efficiency, since the use of the locomotives could increase considerably. Coordination is particularly crucial in the last kilometres of the track, due to the numerous small sorting activities that lead to downtime for the locomotives. Another coordination problem is the limited exchange of goods between railway operators and/or shippers. This cooperation could generate economies of scale and higher equipment utilization rates, but does not develop spontaneously.

### 3 INTEGRATED PORT-HINTERLAND HUB CRITERIA

The main properties of an ‘integrated port-inland hub’ can be summarized as follows:

- efficient physical transfer processes between modes;
- efficient administrative processes (i.e. customs) inland;
- two-way data sharing between operational actors and between operational and public actors (compliance);
- visibility of the port-hinterland available to the operational actors and the shippers;
- existence of regular ecological services (fixed hours, at least 1/week) (rail/barge) inland;
- a considerable proportion of railways (for example > 10%) in the international hinterland throughput;
- information on environmental sustainability shared with the local community.

The problem of making the port-hinterland system an efficient and integrated hub must be tackled on different levels by analysing the infrastructural, operational, institutional, market and innovation prospects.

From an infrastructural point of view, it can be argued that a good network of roads, railways and rivers/canals, together with efficient interconnection systems, is a first requirement for the easy multimodal accessibility of the hinterland. The infrastructural system must be planned, designed and built in order to achieve a real integration between port and hinterland with fast and efficient connections capable of satisfying the territory and market demands. In the sector literature there are many studies on optimal network design and the development of seamless interfaces between chain links (Koning, 2009).

From the operational point of view, it is necessary to guarantee a hinterland transport and logistics system that is operationally efficient able to offer fast, frequent and reliable transport, value-added services for goods and based on effective cooperation and real coordination between the actors involved in the logistic chain.

As far as the institutional framework is concerned, it is necessary that the administrative processes are streamlined and the management of the entire system is coordinated in order to guarantee and sustain the overall efficiency. The port-hinterland system must have a management structure capable of enhancing resources, putting them into a system with the aim of strengthening existing activities and attracting new ones.

From the market point of view, it can be argued that efficient and effective companies must exist that provide customers with various land transport services allowing the attraction of traffic to/from the port. The paradigm is that these companies thrive most in a liberalized and competitive environment.

From the innovation point of view, it must be emphasized that ICT solutions are very important to simplify both the administrative procedures related to multimodal transport and to efficiently manage the information flows that are generated between the actors in the logistic chain. So real-time ICT information initiatives can also be

implemented between nodes to monitor and increase the effectiveness and efficiency of the supply chain and its basic operations.

Although separate, these aspects are highly interdependent. The five components need to be developed simultaneously to insure the overall efficiency and effectiveness of the system (Figure 14).

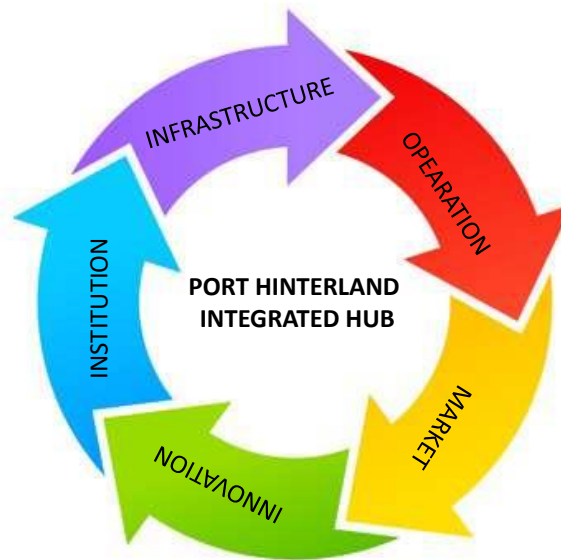

Figure 14: Levels of analysis

### 3.1 Infrastructures

The infrastructure requirement responds to the need to meet the mobility demand: not only the current one but also the future one, expected in relation to the evolution of the demographic and socio-economic context, at national and international level.

The “unsatisfied demand” or the demand increase requires an adjustment of the capacity of the existing infrastructures, where they are congested or they do not guarantee an adequate level of service, through the construction of new infrastructures or the technological and management actions (for example, the speeding up of a railway section, the rationalization of port connections, the increase in services, etc.).

The choice to improve the infrastructure system around a port node is oriented, in addition to satisfying the freight demand, to enhance services in order to improve accessibility and make the node more attractive by increasing the extension of its catchment area.

Certainly, the digital transformation of infrastructures represents a fundamental factor for the sustainable, intelligent and integrated growth of port systems and their hinterland. In fact, digital transformation allows to create new, light, quality, safer, cheaper infrastructures, which generate data and services for a more efficient freight logistics.

The creation of an integrated port-hinterland hub requires integrated transport infrastructures that allow a reduction of transport times and costs, enhanced accessibility, energy savings and a minimal impact on the environment.

The competitiveness of port-hinterland systems in the ADRION area is related to adequate connections and fast and reliable transport and logistics services with Europe and the Mediterranean. As regards the European TEN-T networks, it is necessary to envisage the improvement of the rail and road links connecting to the Core and Comprehensive network and the improvement of the last mile connections. With regard to accessibility to the Mediterranean basin, an area rich in economic opportunities especially in terms of commercial exchange, the strengthening and improvement of the feeder and Ro-Ro maritime connections to the countries of the Mediterranean area is important.

To ensure complete integration of ports with their hinterland, it is necessary to operate on two levels:

- on the port infrastructure with particular reference to the interface between the port and the nearest main transport network (railway and road gates, barge);
- on the infrastructures that guarantee connections with the largest hinterland (road network, external railway networks).

In the first case, the problem concerns the separation of freight traffic from local traffic both within the port area and on the last mile routes.

In the second case, it is important to guarantee the characteristics of the railway infrastructures that allow the transport of loading units on international standards (High Cube, Rolling Road, ...), with suitable modules (550-750 m) in order to connect the territories at regional, national and transnational level ensuring the sustainability of freight transport.

## 3.2 Operations

Ensuring integration between ports and hinterlands requires:

- the design of transport system otherwise of connection efficiently system;
- value-added services along the logistic chain;
- coordination and organization of the activities and actors involved.

Transportation is a fundamental component of the logistics cycle; in fact one of the primary objectives of companies is to move input and output of production cycles quickly, safely and economically. The design of a transport system aims to match the demand (material flows) with the supply (infrastructure). The choice of the most suitable mode of transport or combination of modes for inland penetration is based on many factors such as transport volumes, distance, time restrictions, product value, availability of services, etc.

Different transport modes are characterized by different operating conditions and have different capacity limitations, also in relation to interchange terminals.

In particular it is necessary to consider some characteristics of transport services, as:

- *capacity*: the amount of goods that can be shipped over a period of time;

- *capability*: the range of skills and abilities of the transport provider, e.g. available modes of transport, customs clearance, access to inland clearance depots, handling possibilities for load units such as refrigerated containers, bulky shipments, etc.;
- *transit time*: the total time taken to send the goods to the final destination, which is calculated from the order until the completion of the transport activity;
- *frequency*: the number of services offered in the unit of time (e.g. number of trains departing in a day or a week);
- *reliability*: the ability to respond to demand needs on the base of planned services.

It is important to note that the transit time is a key component since it affects the overall delivery time, and therefore also the costs (fixed assets, etc.) and helps to determine customer satisfaction. Instead, the frequency determines the overall availability of the service. The frequency, in combination with transit time and reliability, is often of particular interest, since it influences the turn-around time for products and load units, and therefore the quantity of load units required and the products connected in the transport .

In the design of the transport system the consideration of intermodal transport becomes fundamental. Intermodality arises from the use of several basic transport modes to perform a transport on a predefined relationship. The crucial element, to which roles and functions of intermodal transport are strictly connected, is given by dividing the total distance into partial sections, each to be covered with a specific carrier, so as to minimize the costs associated with the transfer of goods from origin to destination. From this point of view, looking at the port-hinterland connection, the port and the inland intermediate terminals play a crucial role and the advantage of making the transfer by using a specific chain of basic modes depends on their efficiency. Therefore the competitiveness of the basic modes (road, sea and rail) is mainly a function of the distance to be covered and the efficiency of the freight interchange nodes. As an example, consider road transport, rail transport and combined road-rail transport and proceed to the construction of a generalized cost - distance diagram as shown in Figure 15. In the case of road transport, the cost associated with shipping increases linearly in proportion to the distance; where the railway modality is considered, after an elevated cost of access (due to the fact that the railway is not able to ensure capillarity in the territory), the cost of transport grows linearly with the distance, but in a more contained way than what happens for the road mode; if a combined transport is considered, in which the access section to the railway is guaranteed by a road transport, the costs of the entire transport are lowered considerably as long as the cost associated with the transit of the goods at the node (in Figure 15 this cost is represented by the discontinuity  $K_t$  in the combined curve) they remain below a certain threshold. Ultimately, the costs at the node represent an important component of the total transport cost; these are costs that are independent of the length of the trip and vary significantly in relation to the “involved” transport methods and any storage and treatment carried out on the goods in transit to the node itself.



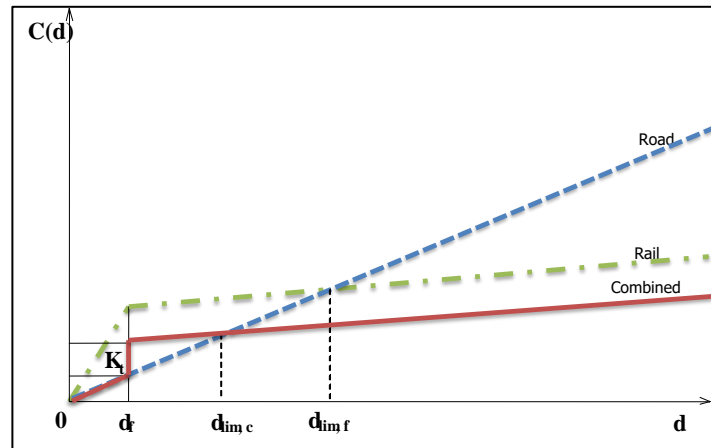

Figure 15: Cost-distance diagram

This type of analysis, known as break-even analysis, makes possible to obtain information to support decisions regarding the transport mode, or the combination of transport modes, which is more advantageous, in monetary and temporal terms, for the execution of a shipment.

In terms of value-added services in port-hinterland connections, it is necessary to guarantee the presence of activities along the supply chain, which allow to increase the efficiency and effectiveness of the system and the satisfaction of the end customers. For example, we need to provide inventory management, storage, pre-assembly, production, packaging, maintenance and repair services, reverse logistics, etc., always ensuring quick and functional decisions.

The strategic component in the hinterland logistics system is characterized by the actors involved in the system and the logistics services they provide; for this reason, it is fundamental an operational cooperation and coordination. It is necessary to guarantee processes and procedures in the firms' boundaries activities, which allow to improve the performance of the operators involved in the supply chain, through constant connections and relationships among all partners in the supply chain. To achieve this goal you need: a collaboration with channel members, a benchmark of logistics management options, integrated promotion activities, the sharing of risks, costs and benefits, the creation of long-term relationships among stakeholders, joint research for end customer satisfaction, teamwork, the use of common performance indicators.

### 3.3 Market

The shipping market is influenced by many factors such as the trend of the global economy, international trade, geopolitical strategies, environmental regulations, the characteristics of the fleets. Ports, together with their hinterland, as key systems of international trade and critical nodes in global logistics chains, must face the challenges deriving from the changing dynamics of the markets, from the need to catch the technological progress determined by digitalization, by a global sustainability agenda, while seeking to remain competitive and meet the needs of the world economy and commerce. Port hinterland systems that want to present themselves to markets as efficient, integrated and sustainable hubs must reassess

their role in global logistics chains and prepare for the impacts related to the accelerated growth of technological advances. The improvement of port performance and the ability to effectively integrate with the hinterland in all market segments is increasingly recognized as a fundamental element for port planning, investments and strategic positioning, as well as to achieve benchmarks and sustainability objectives at global level.

In this context, the analysis of the impact of the market concentration of an integrated port-hinterland system is relevant. This analysis requires considering the markets in relation to different aspects such as:

- the commodity profile and related segments as well as the relative weight of the port for a given commodity category;
- the profile of the types of transport services (containers, ro-ro; etc.);
- the size of the reference hinterland; in particular, as regards the land hinterland, its extension (local, national, international) and as regards the maritime hinterland, the relevance of the connections with the main intercontinental, Mediterranean and / or national economic areas;
- the distribution on the territory.

The combination of this information allows to frame the port and its hinterland in a system vision, not limited to simply observing the volumes handled, but investigating roles and functions performed in the reference markets. In this context, even the so-called “minor” ports can play an important role, both in terms of specialization of traffic, markets served, geographic position, and because, although operating within the same market, they tend to integrate in the system.

A complete market analysis that takes these aspects into account must lead to the definition of:

- marketing policies to enhance the image of the port and encourage the opportunities for setting up production and commercial activities in adjacent areas, also aiming to attract domestic and foreign capital;
- incentives for the use of rail transport as an alternative to road transport (iron bonus);
- creation of Special Economic Zones (SEZ) which are a free port paradigm that has been particularly applied as a tool to promote foreign direct investment in well-defined areas;
- local and international promotional initiatives (for example, trade fairs such as the one organized in Padua - exhibition of international sustainable logistics titled “Green Logistics Expo - Where efficiency meets environment”).

### 3.4 Innovation

The modern trend of freight transport leads to greater attention towards ICT solutions in order to make transport logistics chains efficient and reliable. The technological standards are constantly evolving and offer solutions aimed at streamlining procedures, reducing transport times and costs, saving energy, respecting the environment in a 360-degrees sustainability perspective.

Digitalization, sensors, telematics, cloud computing and, more generally, the technological innovation of material and immaterial processes, make the port system a true “smart community”, able to catch the development opportunities generated by the “logistics 4.0” which imposes a new approach and a new governance model, not only in technological and industrial terms, but also in economic and social terms. Intelligent and digitally interconnected systems ensure direct communication between operators, equipment, plants, logistics and products, and consequently allow an improvement in productivity, visibility, tracking and safety/security. These systems allow safety in transport planning, better exploitation of fleets and reduced waiting times for freight loading/unloading.

This phenomenon affects directly the port nodes, it deeply influences the choices in both public infrastructure and private investments, and it changes the nature of cargo ports.

The use of ICT makes it possible to improve the port-hinterland system on different fronts: monitoring, information flows management, road traffic management, automation in port and in the port-hinterland connections.

### 3.4.1 Monitoring

Ports are complex environments characterized by a variety of activities aimed at handling different types of goods, both containerized and non-containerized. Numerous public and private actors, specialized in production, packaging, shipping and transport activities, operate and interact in them. In this scenario, advanced monitoring systems become essential for the control of processes, activities and material and immaterial flows. The variables and events of interest for the complex port system are countless: boarding presences, weather data, pollution sensors, surveillance, info-mobility, etc.

An advanced monitoring and control system is MONI.C.A., active in the port of Livorno (Port System Authority of the Northern Tyrrhenian Sea, 2018; Pagano, 2019). The MONI.C.A. platform (Figure 16) is characterized by a multilevel architecture capable of integrating, aggregating and processing information deriving from multiple sources (field sensors, embedded sensors, Internet of Things, HW/SW middleware systems, vertical or specialized information systems, etc. ...). The information is presented to the user through a representation in Virtual Reality of the port system, with photorealistic and geo-referenced 3D graphics, and with real-time updating of the global information framework.

MONI.C.A. allows to:

- monitor and control in real time the port, peripheral port and dry-port areas through the integration and display of data collected by the networks of cameras (visible, OCR, infrared, ...), sensors (environmental parameters, sensors on systems and infrastructures), transmitters and receivers (UHF / RFID, AIS, radar, etc.);
- connect middleware systems for data transformation and translation;
- acquire data from specialized information systems for the management and integration of complex processes.



Figure 16: MONI.C.A. Platform

The functional areas of the MONI.C.A. platform can be summarized in the following points:

- **Safety** (work and dangerous goods) guaranteed through sensors for the detection of chemical substances; sensors on board the handling means, both for anti-collision purposes (man-vehicle and vehicle-vehicle), and for the purpose of monitoring the goods transported; OCR systems for the recognition of dangerous goods plates; “thermal” video surveillance systems; drones and services for integration with IT systems responsible for the management of dangerous goods and their traceability;
- **Security** (personal safety) guaranteed with the use of OCR vehicle plate recognition systems; “optical” video surveillance systems at gates and parking areas and integration services with IT systems of the security forces;
- **Traceability** in the logistical processes, freight handling and vehicles movements , guaranteed with the use of passive and active on-board-units (OBUs), with radio frequency transmission (RFID, Bluetooth 4) or over-IP (networks 2G, 3G, 4G) and related reception devices; OCR systems for the recognition of vehicle number plates at gates and internal and external communication routes; sensors for railway traceability;

- *Navigation* for the monitoring of navigation in port waters and, for ships in the intersection points between commercial and private traffic through the use of AIS transducers; on-board-units (OBU) both passive and active, with radio frequency transmission (RFID, Bluetooth 4) or over-IP (2G, 3G, 4G networks) and related reception devices; berth sensors; “thermal” video surveillance systems;
- *Environment* for monitoring environmental parameters (marine weather data, air and water quality, spills, fumes, noise pollution, etc. ...) with the use of weather stations; anemometers; tide gauges; environmental sensors; drones;
- *Infomobility* to provide users with real-time information on the weather, traffic situation, forecast arrivals and departures of ships with the use of stations for detecting traffic; license plate recognition OCR systems; weather stations; drones;
- *Maintenance* for the monitoring and control, for maintenance purposes, of port and logistics infrastructures, subsystems and sub-services through bathymetric sensors, in fixed and mobile locations; sensors for structural monitoring of docks; sensors for monitoring water pipes, gases, chemicals; drones.

MONI.C.A. platform is composed by three levels (Figure 17):

- *IaaS (Infrastructure as a Services)*: this level includes the network infrastructures used for connectivity within and between nodes and also includes the network devices for collecting and acquiring data;
- *PaaS (Platform as a Services)*: the standard digital platform used for the collection, historization and aggregation of data from intelligent devices and other connected legacy IT devices;
- *SaaS (Software as a Services)*: this level includes the set of applications and services that allow the use of information through appropriate graphic interfaces; this level includes the tracking, monitoring, control, risk assessment, rendering, big data, parking management, etc. services.

MONI.C.A. platform proposes interfaces for IoT and 5G sensors.



Figure 17: MONI.C.A. Structure

(Source: Port System Authority of the Northern Tyrrhenian Sea, 2018)



### 3.4.2 Information flows management

The evolution of ICT has allowed the development of fast systems for the exchange of information and data, favouring the management of information flows related to the transport of goods. In the port area, the so-called PCS - Port Community Systems, have been developed.

The PCS is an ICT platform that can play a key role to integrate the electronic flow of information between all the port community partners involved in the maritime transport chain, including Shipping Agents, Freight Forwarders, Customs Brokers, Terminal Operators, Health and Safety Authorities, Inland Transport Operators, etc. The main purpose of the PCS is sharing information between all actors involved in port operations, facilitating the streamlining of import/export processes and offering instant access to information that can be used to handle port operations in a more efficient way.

Figure 18 shows the improvements that can be achieved with the use of a PCS.

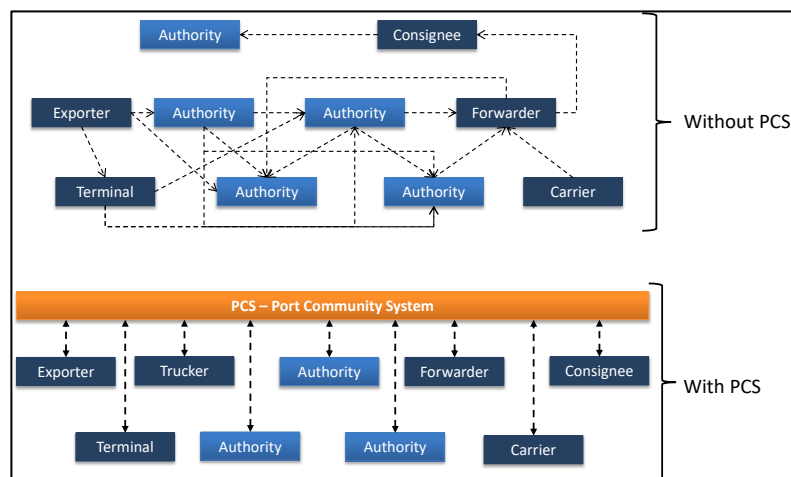

Figure 18: PCS advantages in information flows

In the absence of a PCS, the information system is based on a complex and expensive peer-to-peer messaging which often involves the use of paper documents, slow and expensive manual information management processes with consequent delays in transport and logistics. Moreover, inconsistent information across organizational boundaries and “blind spots” throughout the supply chain hinder the efficient flow of goods and consequently the administrative cost of handling a container shipment is comparable to the cost of the actual physical transport.

Instead, a PCS:

- allows instant and secure access to end-to-end supply chain information;
- guarantees the authenticity and immutability of digital documents with reliable inter-organic workflows;
- provides better risk assessments and less unnecessary interventions;
- allows to have much lower administrative costs and the elimination of costs to move the physical card beyond international borders;
- allows to obtain a global savings resulting from a more efficient sharing of information.

Figure 19 shows in detail the information and physical flows that can potentially develop with the use of a PCS.

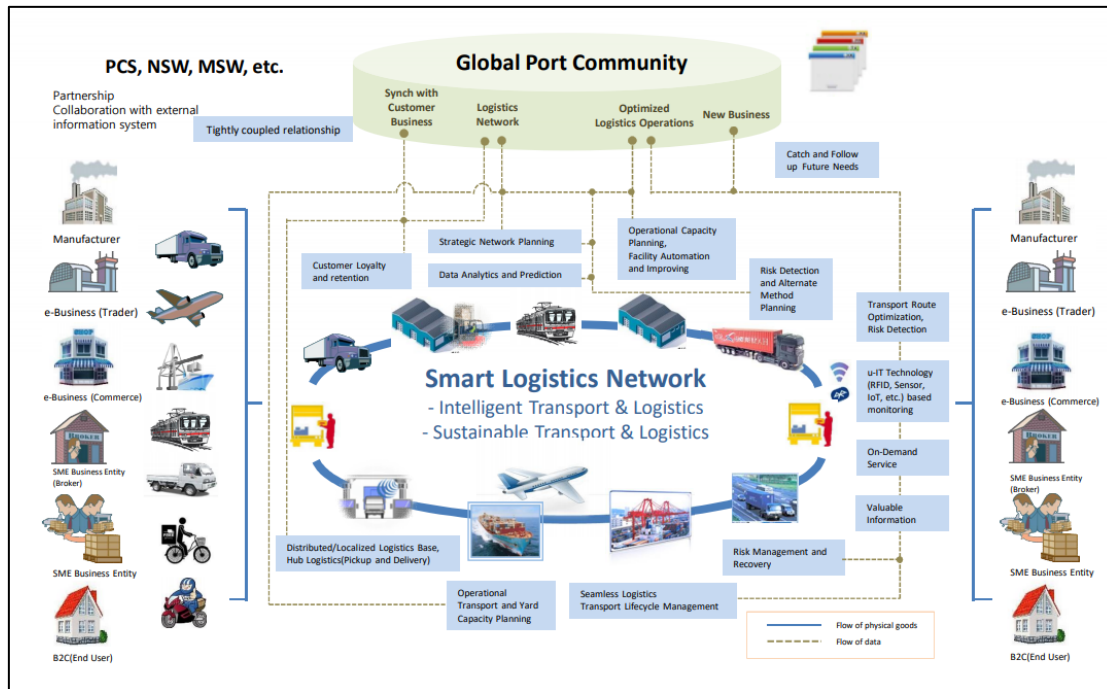

Figure 19: Global Port Community System  
Source: Ahn, 2018

In Europe and in the world there are numerous examples of PCS operating in the ports of Hamburg and Rotterdam (PORTBASE), in the port of Antwerp (APCS), in China (LoginK - National PCS), in Japan (Collins - National PCS). There is an international association (IPCSA - International Port Community System Association) whose mission is to “influence public policy at the international level, principally by lobbying, in order to promote the adoption of e-logistics as the key element in the development of international maritime, shipping and logistics sectors.”

### 3.4.3 Road traffic management

In many ports and ports cities, the port gate strategy was launched to reduce idle trucks in ports and mitigate the traffic so as to reduce urban congestion and environmental impacts. The major policy instrument in this regard is terminal appointment system. The main aim of the appointment system is to decrease congestion on the roads to ports or at ports by granting special treatment to trucks that schedule themselves in the appointment system. The feature of this system is that terminals allocate timeslots for trucks to come to ports, which enables them to spread truck flow more uniformly throughout the day. The system typically utilizes the internet, where an application is submitted providing information to gain clearance before the truck’s call at the port. These applications have developed the flow of trucks, increased terminal throughput and improved productivity for trucking companies and terminals. In addition, truck turnaround time was reduced by 30% on average, as in the case of Georgia Ports Authority (Merk and Notteboom, 2015).

### 3.4.4 Automation

In the last years an increasing interest is addressed to the technologically advanced vehicles with high levels of automation. In the sector literature (SAE International, 2014; Keese et al., 2016; VDA,2018), five different levels associated with the development of automation are identified (Figure 20):

- Level 0 - No Automated Driving: the driver is fully responsible for driving;
- Level 1 - Assisted: system assists with speed, braking and steering, while the driver remains fully responsible;
- Level 2 - Partial Automation: driver can hand over to the system in specific applications, but must remain able to take over control again immediately;
- Level 3 - High Automation: system performs driving tasks in defined use cases, but return control to driver beyond defined parameters;
- Level 4 - Full Automation: driver can hand over the entire task of driving to the system in specific use cases;
- Level 5 - Autonomous driving: system can handle all driving situations without driver.

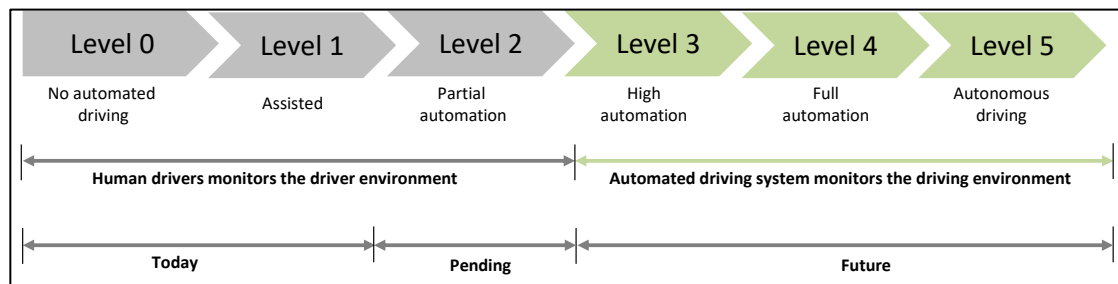

Figure 20: Automation levels

The interest for automation is on the rise; there are many benefits in automation, such as lower labour cost, all day operations and higher reliability.

In many ports, technological innovation has made it possible to automate goods handling activities. Container handling can be carried out by highly automated vehicles such as the Automated Guided Vehicle - AGV, the Intelligent Autonomous Vehicle - IAV, the Automated Straddle Carrier - ASC, the Automated Transtainer - ATT (Gattuso and Cassone, 2018).

AGVs, presently used in the ports of Rotterdam (Figure 21), Hamburg and Singapore, allow horizontal cargo handling; a specific version is called Lift-AGV because load lifting occurs thanks to special mobile platforms placed in correspondence to the loading platform. In both cases, they are simple, flexible vehicles, with a reduced mass, low consumption, and high loading capacity (about 60 t). An AGV is generally used instead of the straddle carrier for transfers to and from the quay and the loading yard. It is placed at the buffer crane and when the container has been loaded, it moves along guides traced on the terminal surface, until it reaches the pre-defined position where a gantry crane retrieves and stores the container. At the yard blocks there are racks where the automated vehicle can deposit the container without waiting for the crane to pick it up; in this way downtime is avoided, and the vehicle's productivity is enhanced. AGVs are controlled and supplied with data and orders by management and navigation software.



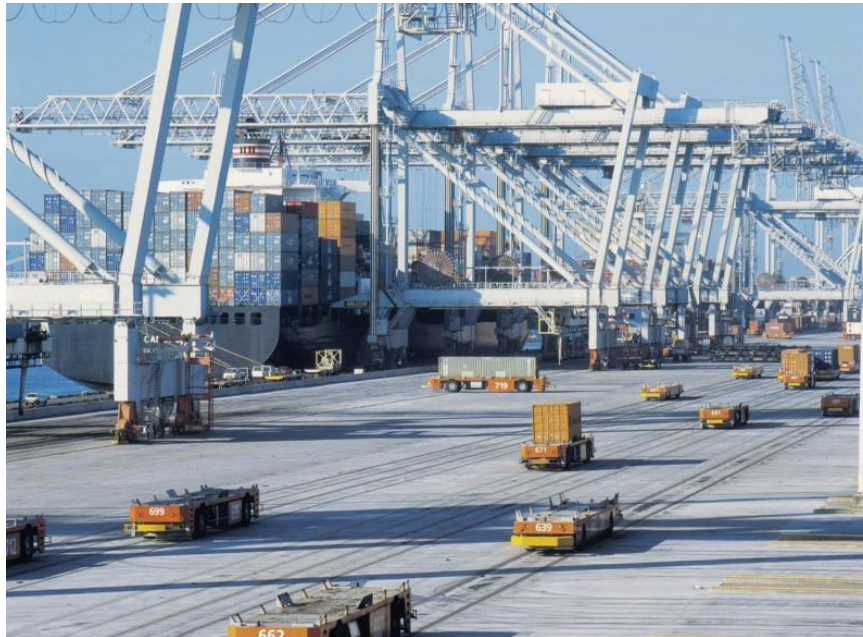

Figure 21: Automated Guided Vehicle in Rotterdam port

An interesting type of handling unit in loading areas is the IAV (Figure 22); it is still a prototype and it was developed in the European Project INTRADE (Intelligent Transportation for Dynamic Environment) coordinated by Lille Polytechnic (Merzouki, 2014). It is like the AGV but, instead of moving along a fixed track on the yard surface thanks to an incorporated transponder, GPS systems and other sensors allow it to move freely. The remote navigation system operates in a virtual environment, therefore the vehicle can move in any direction within a defined area; so it is possible to form self-driven or tractor-driven ‘trains’. The connection between the two IAVs is not physical, it is virtual and works via specific sensors placed on the vehicles.



Figure 22: Intelligent Autonomous Vehicle

There are also cases of ASC (Figure 23) and ATR (Figure 24), controlled by advanced computer systems; their unit cost increases considerably (about 2.2M€ for ATR), but the driverless activity gives interesting lower management costs.



*Figure 23: Automated Straddle Carrier*



*Figure 24: Automated Transtainer*

The automated transport of goods to the hinterland is still in an embryonic stage, even though many researchers are working in this direction, taking inspiration from the automatic systems used in the collective transport of people. Visser et alii (2007) provide a framework of possible innovative technologies to be used in transport from ports to their hinterland in a range of 50-150 km. Among the identified technologies there are:

- automated truck and multi-trailer systems;
- automated trains;
- automated barge handling systems;
- automatic systems of alternative railway capsules.

Automated trucks can be operated in any weather conditions without the driver behind the wheel ensuring a transport service over medium-long distances. Their performance and potentiality can be significant when considering multi-trailer automated systems or an automated truck combined with multiple trailers. This type of vehicle can operate 24 hours a day, providing a maximum capacity of around 1,000 TEU/h at relatively low speeds (11 km/h). The use of automated trucks requires dedicated roads (or road lanes), completely reserved also for legal and safety issues. Therefore the initial investment cost is high and justified only by a high use of the system.

The use of these vehicles for freight transport on medium-long distance allows to:

- increase safety and reliability by reducing drivers' workload and human errors;
- increase productivity;

- enable platooning to reduce energy consumption and emissions due to aerodynamic drag reduction;
- decrease distance between trucks reducing road area used and improving the use of groups of trucks;
- reduce operative costs (driver, maintenance, fuel, etc.) with a reduction of transport and goods costs.

Also, the benefits for the community in economic and environmental terms are remarkable, the use of these vehicles in fact allows a reduction of polluting emissions, accidents and road congestion with an increase in transport safety.

Figure 25 shows the results of a study conducted by EIA - NHTSA - BLS - Roland Berger in 2016. Specifically, it should be noted that the use of automated TIRs for the transport of goods lead to a progressive reduction in fuel consumption and an increase of road safety.

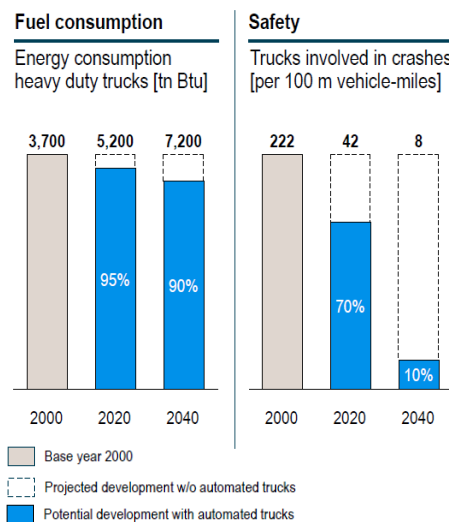

Figure 25: Potential changes resulting from the use of automatic trucks  
Source: Keese et alii, 2016

Automated trucks can be used to transport containers and could be applied in a relatively short time. Demonstrations have shown the technical feasibility.

Autonomous systems save time, costs and personnel - and are not strictly limited to the road. A lot is currently being written about self-driving trucks, but there are similar developments for rail transport.

The research on freight train automation can basically be classified into two categories:

- automation technologies aimed at improving train performance;
- autonomous train (driverless).

In the second case, the attention is focused on driving control technologies; the problems are numerous and range from motorization to autonomous driving, from the control system architecture to the aspects of vehicle safety management and the surrounding environment. In both cases, the technological solutions differ according to the type of transport (Figure 26).

Freight can be moved by rail using two different types of transport: single wagon or shuttle train. Single wagon transport bases its strength on the presence of an intermediate sorting plant within the transport chain. Between the origin and the destination, the railway wagon can travel on different trains in order to optimize its circulation both from the productive and economic point of view. The most suitable transports for this typology are those to low frequency or that have a seasonality. Instead, a shuttle train is a freight train that travels from the loading point to the unloading point without intermediate stops; in this case we speak of a point-to-point traction service.

For single wagon transport, research is moving towards the construction of automatic railway wagons, while in the logic of shuttle trains, transport experiences have already been carried out with automated and autonomous locomotives.

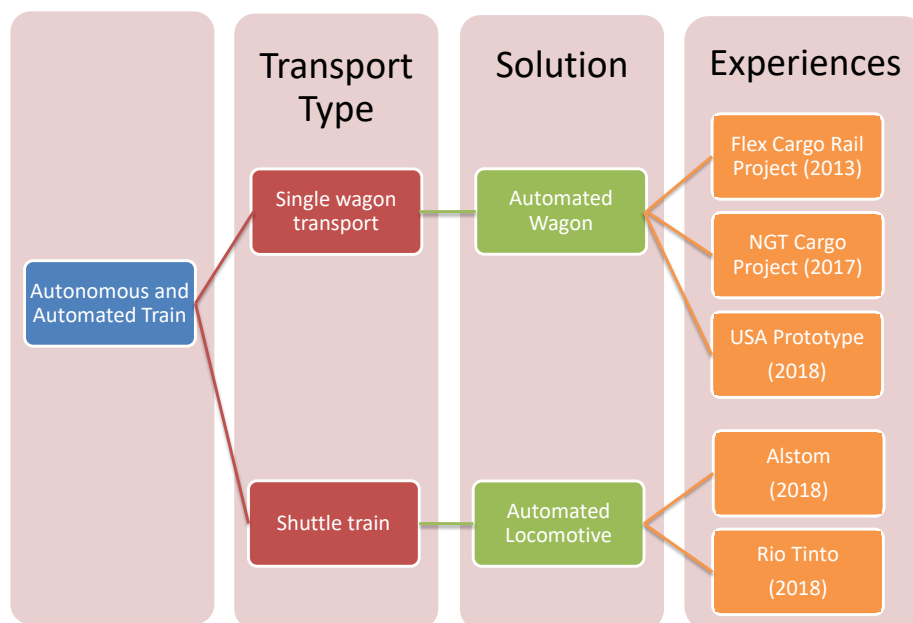

Figure 26: Automated railway transport

The FlexCargoRail system focuses on electrical powered, radio controlled freight wagons to raise movement flexibility of the wagons for shunting operations and to grow efficiency of the single wagon load traffic. The single wagons are electrically self-propelled and are operated via radio remote control by personnel in the yard. FlexCargoRail (Dickenbrock et al. 2009; Jeschke, 2011) is not an autonomously driven and self-organizing rail freight wagon system. The idea is to accelerate the shunting processes and to bring in more flexibility. As each FlexCargoRail wagon is equipped with an electric drivetrain and a battery, distributed traction for freight trains - as already applied to modern passenger trains - could be a future extension of the system. Unlike the initial situation in which all wagons have to be pulled by a locomotive, the main advantage of FlexCargoRail is that every single payload carrier equipped with FlexCargoRail technology can be moved independently from the switcher/locomotive during shunting (Figure 27).

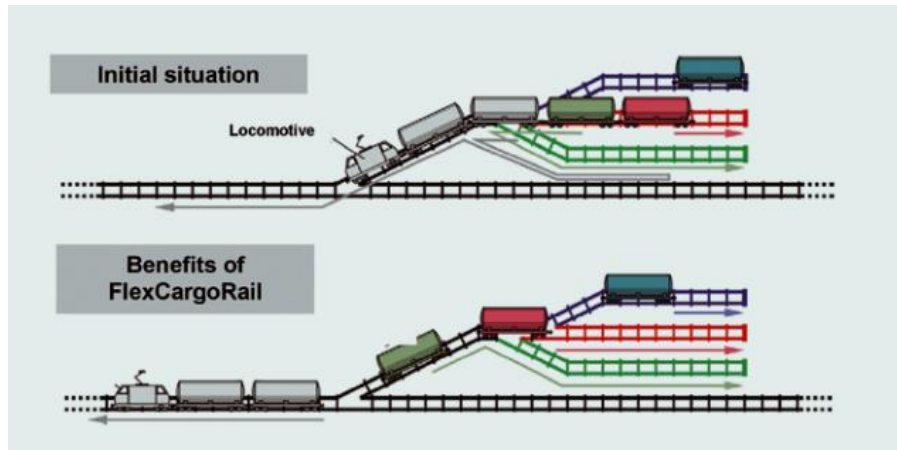

Figure 27: Benefit of FlexCargoRail  
 Source: Dickenbrock et alii, 2009

A concept for the next-generation transport of cargo by rail - NGT CARGO - is proposed by German Aerospace Center (Deutsches Zentrum für Luft- und Raumfahrt-DLR, 2017; Himmelstein, 2017; Malzacher et al., 2018) to broaden the market share of European rail freight. Combining a high level of automation, intelligent handling and high speeds should render rail freight transportation more flexible and increase system capacity. Currently, an elaborate process using rigid operating procedures underlies single wagon transport. Coupling and uncoupling wagons, picking them up and delivering them is very time- and resource-intensive and accounts for 30-40 percent of overall costs. Manual coupling processes lead to long idle periods for individual wagons and an average system speed of just 18 km/h for single-wagon transport. A lead time of approximately five days is required to make the personnel, material and routes available. Intelligent freight wagons in the NGT CARGO concept have a separate drive based on electric motors and a battery that stores energy recovered during braking. Single wagons shunt autonomously, without the need for staff, locomotives or overhead lines. Each wagon is equipped with sensors that enable travel of the last kilometres to the respective customer automatically and autonomously. The wagons can also be driven directly into ports, transshipment stations or logistics terminals, right up to the high level racks, where they are also loaded or unloaded automatically. For operation at high speeds, the NGT CARGO single wagons form a unit and are combined with one or two end cars, which provide the necessary drive. With the appropriate infrastructure, up to 400 km/h is conceivable. Speeds of up to 160 or 200 km/h are attainable on existing lines.

Meanwhile, tests have been operated in Europe and Australia to assess the possibility of freight trains driven by an autonomous and automated locomotive. In 2012 TU Dresden - Institute of Railway System, Public and Urban Transport and TU Berlin - Rail Vehicles Department published the White paper "Innovative rail freight wagon 2030" (König and Hecht, 2012). The paper represents a collection of proposal for coordinated implementation and for further developments of innovative freight rail wagon. The central idea consists on overall technical and operational concept for the design and use of rail freight wagon. The paper refers to the "5L future initiative" as the basis for the new growth in rail freight transport. This initiative creates a framework for five growth factors that have been identified for successful introduction of the innovative freight wagon: low noise, light weight, long running,



logistic capable, LCC oriented (Life Cycle Costing). These factors include the following essential properties:

- low noise: reduction of noise emissions;
- light weight: higher payload, less net mass;
- long running: reduction of downtimes and unproductive times, increases average annual mileage, higher reliability;
- logistics capable: possibility of integration into the supply chain, service quality better than/equal to road and air transport;
- LCC oriented: integration of LCC oriented components, with procurement costs rapidly amortised over product lifetime and more than compensate for by cost reduction in operation and maintenance.

An autonomous freight train was tested in the Netherlands by the railway engineering Alstom in November 2018 (van Gompel, 2018). The prototype of the train travelled for about 100 km without driver. Automation allows the driver to focus on supervising train progress. The purpose of the test was to provide a live demonstration that the train and the signal system can communicate effectively to guide the train. Alstom has signed an agreement with the Dutch infrastructure operator ProRail and Rotterdam Rail Feeding (RRF) to carry out the test along the Betuweroute, a 150 km double-track railway line that connects Rotterdam to Germany. The experimentation has been made with a freight train BR203. The tests concerned the Automatic Operation of the Train (ATO), where the automation level 2 was tested. The train operates completely autonomously in level 4. This will not happen in the Netherlands in the short term. The trains equipped with ATO can operate at closer intervals, which increases the capacity of the railway network and allows for reduced energy consumption, because trains operate more uniformly. Automated operation can therefore be an added value for operators facing increasing traffic on the current railway networks without making expensive changes to the infrastructure.

In Australia, in July 2018 a freight train, hauled by three locomotives and carrying around 28.000 tons of iron, travelled more than 280 km from Rio Tinto's Tom Price mine to the port of Cape Lambert without a driver in the cab (Railway Gazette International, 2019). It was monitored remotely by operators from Rio Tinto's Operations Centre in Perth more than 1500 km away. The cost of Rio Tinto's AutoHaul operation (Ansaldo STS, 2018) of heavy-haul trains in Australia's Pilbara region exceeds \$900 million.

In 2018 the DB Cargo/VTG started with tests on new wagon types. The research project "Development and testing of innovative freight wagons" has been subsidized by Germany's Federal Ministry of Transport. The innovations range from the use of lightweight components to energy savings and noise reduction, from customized wagon adjustments to accommodate freight to new digital modules that optimize freight wagon handling.

There is still much to do in this field and it is necessary to proceed gradually. The progress also moves through applications of advanced technologies relating to some components of freight train. Some research are aimed at improving the train performance by means of automation and they appear promising.

Currently, studies of pre-engineering are in progress towards the automation of the wagon (self-propelled drive, predictive maintenance, self-contained auxiliary power, technical specifications of the control algorithm). A specific attention is addressed here to an innovative freight wagon mainly based on a specific technology related to railway bogies.

### 3.5 Institutions

Social, economic and political factors that include government policies, financial and educational institutions are fundamental for the realization of an integrated port-hinterland system.

At institutional level, at local, regional and national level, initiatives should be promoted to:

- support the logistics providers financially;
- approve commercial loans and / or microcredit services;
- facilitate lease agreements;
- evaluate the interrelationships between the logistic functions;
- provide professional education;
- organize, invite and attend participation in training, seminars and conferences.

Also at an institutional level, it should be promoted the collaboration based on trust and the dependence among supply chain partners involving the supply chain stakeholders in the decision-making process.

Last but not least, the port governance which must be efficient and above all cooperative ensuring the involvement of all operational, administrative and bureaucratic components with the aim of streamlining the processes (physical and information flows) in order to increase the competitiveness of the complex port-hinterland system.

## 4 METHODOLOGY FOR INTEGRATED PORT-HINTERLAND HUB

Figure 28 summarizes the proposed methodological approach for the creation of an integrated port-hinterland hub. The methodology traces the path followed for the development of the ISTEN project.

After identifying the study area, it is necessary to proceed with the context analysis aimed at identifying the bottlenecks (concerning infrastructure, operations, market, institutions and innovation) that prevent the full realization of an integrated port-hinterland hub. The context analysis also provides the definition of plausible medium-term scenarios such as an internally consistent view of what the future might turn out to be - not a forecast, but possible future outcome.

The analysis phase is followed by the elaboration phase which provides the identification, punctual characterization and evaluation of a series of actions aimed at overcoming bottlenecks in order to promote and create a port system integrated with its hinterland in the perspective of efficiency and sustainability. This phase is supported through the analysis and study of best practices that present solutions to port-hinterland integration problems; which promote the attributes of port-hinterland integration (efficiency, sustainability, innovation, cooperation and coordination) through innovative ideas with respect to current practices and which can be easily transferred in other contexts.

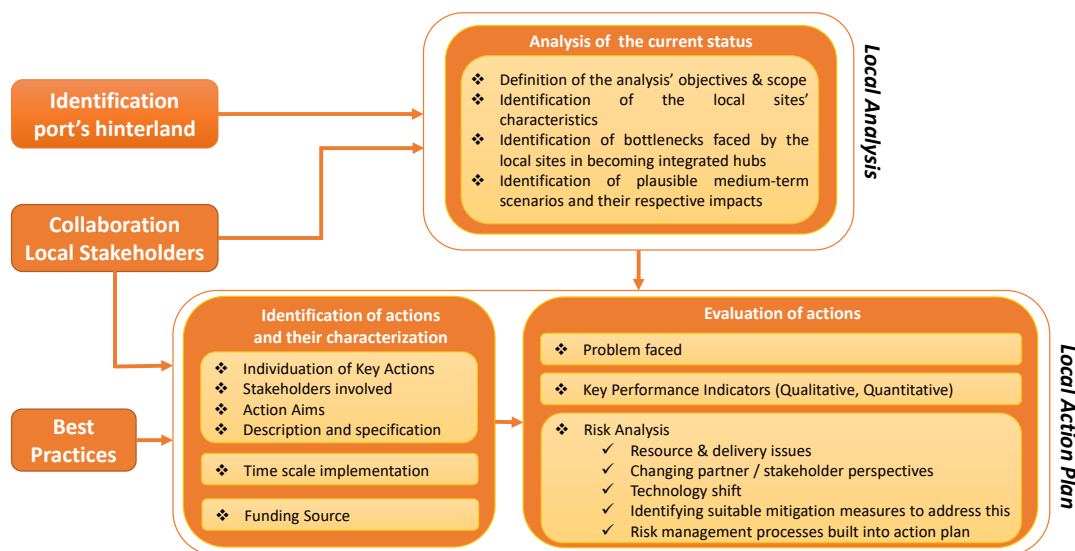

Figure 28: Methodological approach

The whole process must be supported by a continuous interface with local stakeholders, which are an expression of the difficulties and needs of making the logistics chain more efficient, effective and sustainable within the hinterland port system.

The detailed description of the individual phases of the methodological approach is proposed below.



## 4.1 Phase 1: Local Analysis

Similarly to most of the modern industry systems, freight transport and logistics systems are multi-governance ones. This requires the setting up and functioning of inter-institutional cooperation processes and agreements, i.e. the coordination and integration of different stakeholders, their competences and skills in a single logistic chain, whose operation is determined by the availability of infrastructure components as well as machinery, productive as well as procedural and administrative elements.

For this reason, the scope of the analysis of the current status of a port-hinterland system is defined by: the main questions to be addressed; the operational components to be included; and the entities to be involved.

Therefore, the analysis of the current status of the identified hinterland port system provides:

- identification of the local sites' characteristics;
- identification of bottlenecks faced by the local sites in becoming integrated hubs;
- identification of plausible medium-term scenarios and their respective impacts.

The characteristics of each local site will be defined in terms of its:

- port-hinterland chain overview: geography, main markets served and main actors involved (private and public);
- port-hinterland chain operations: cargo served (types, shares, trends), services provided (by each of the main actors involved);
- port-hinterland chain governance: responsibilities of each port-hinterland actor, coordination among port-hinterland actors; networking initiatives with other ports.

The identification of bottlenecks that create problems within the logistics and transport chain and in the relations between ports and hinterland is fundamental because only by overcoming them can an efficient and integrated port-hinterland hub can be created.

The bottlenecks faced at local sites towards realising an 'integrated port-hinterland hub' can be: market bottlenecks, infrastructural bottlenecks, operational bottlenecks, institutional bottlenecks and innovation bottlenecks.

These bottlenecks present in the port-hinterland systems must be identified and analysed through the contribution of the interested parties. Stakeholders have different opinions and perspectives depending on their specific business environment and the level of integration in the port-hinterland system.

The last step for the realization of the context analysis requires the identification of a set of plausible medium-term scenarios and their respective impacts. The scenarios are an internally coherent view of what the future may prove to be - not a prediction, but possible future outcomes. Therefore, their emphasis falls on possibility rather than prediction.

The design of the scenarios depends on the development strategies at different scales. In particular, plan and program tools, community projects and other tools that could influence the scenario structure should be considered. It is possible to distinguish these elements on three geographical scales: transnational, national, regional and local.

The development of alternative scenarios can be achieved with the use of morphological analysis, which includes the following steps:

- the main factors (wildcard, i.e. high impact events / problems) that influence future development are identified;
- for each factor, some conceivable development variants (states) are defined;
- the main factors and the corresponding development variations are inserted in a table called “morphological box” or “Zwicky box” (after its inventor Fritz Zwicky);
- the development variations are combined in plausible filaments;
- each wire constitutes the main cell for a scenario.

## 4.2 Phase 2: Local Action Plan

The second phase of the methodological approach involves the creation of an action plan aimed at creating an integrated and efficient port-hinterland system that is economically, socially and environmentally sustainable.

The action plan is a planning document which contains a detailed description of a series of individual actions aimed at a general common objective, the “framework objective”.

The Action Plan (AP) must be subject to an evaluation, to understand the effectiveness of the actions implemented and to define their impact on the current situation. To make this possible, every action in the AP must be adequately analysed and described, according to a series of principles and must be properly assessed.

For this reason, the second phase of the methodology foresees two sub-phases:

- identification of actions and their characterization;
- evaluation of the actions.

The definition, characterization and evaluation of the actions can be carried out following a CANVAS approach (Figure 29).

Stakeholders involved	Key Actions	Aims	Problems faced	Timescale implementation
Which are the main stakeholders identified and engaged you consider important to reach your objective	Main steps to solve the problem and to reach your objectives	The value proposition of your action. In this section you may list the main objectives and why you are considering this action so important	List here the main problems you encountered during the definition of this action plan	Steps and actions linked to a timeframe important to estimate when the action will be implemented.
1	2	3	4	5
<b>Funding sources</b> Source of funding: EU grants / subsidies National and regional government subsidies Revenue funding from public sector activities Private sector operators, developers, industry Other sources such bank loans & private investment		<b>Risk analysis</b> Understanding why actions fail to deliver? Doesn't achieve required outcome Resource & delivery issues Changing partner / stakeholder perspectives Technology shift Identifying suitable mitigation measures to address this Risk management processes built into action plan		
7		6		

Figure 29: CANVAS Approach

The Business Model Canvas is a strategic Business Design tool that uses visual language to create and develop innovative, high-value business models. It is a summary document that includes the fundamental elements for structuring an idea / action in a coherent way.

#### 4.2.1 Identification and characterization of actions

The identification of the actions to be implemented must be carried out on the basis of the context analysis. The actions, in fact, must be aimed at overcoming the market, infrastructure, operational, innovation and institutional bottlenecks that obstruct the creation of an integrated and efficient port-hinterland system. The actions should be integrated and complementary so that each one can sustain the others and the final result can benefit from the combined effect of the different actions. The identification of actions must involve local stakeholders directly and collaboratively, who may have a different point of view on the same topic.

The characterization of each action requires:

- *the aim*: the value proposition of action.
- *the key actions*: main steps to solve the problem and to reach the objectives. The steps to carry out the action must be identified and listed in a sequence that starts from the beginning and ends with the overcoming of the bottleneck identified and specific for the relevant category.
- *the stakeholders involved*: the main stakeholders identified and committed considered important in order to respond to the main objectives of the action.
- *the timescale implementation*: steps and actions linked to a timeframe. All the key actions already identified must be entered within a period of time. The construction of a timescale is very important not only for the coordination of the implementation, but also for the monitoring process during a possible implementation. Adequate times must be foreseen for each phase (some phases require considerable times such as the development phase, which includes feasibility and implementation).

To make the action concrete, it should be linked to a specific available budget. There are several sources from which it is possible to apply, some of them are:

- European grants or Subsidies (e.g.: Connecting Europe Facility, European Territorial Cooperation, etc.);
- National and Regional Government Subsidies, e.g.: Regional Operational Programme Funds;
- Revenue funding from public sector activities;

- Private sector operators, developers, industry;
- Other sources such bank loans & private investment.

It could be useful also to add an estimation of the needed budget. Financial resources must keep into consideration the professional skills, instrumental resources, infrastructures, and other types required.

#### 4.2.2 Evaluation of actions

The evaluation of the actions can be carried out through:

- the identification of possible problems related to the implementation of the action;
- the risk analysis;
- the use of specific performance indicators (KPIs).

The existence of some specific requirements necessary for the implementation of the action must be underlined to assess the feasibility. In addition, drivers that could help the implementation process and obstacles that could threaten it must be analysed.

The risk analysis aims to examine the adverse events to which the implementation of the action is subject and to identify possible risk prevention or mitigation actions. The risk analysis must:

- explain the conditions of feasibility of the action;
- list the subjects involved in various ways in the process implementation with related responsibilities;
- identify the factors, events and situations that they can configure causes of criticality for the action;
- indicate actions to counteract the onset of critical issues;
- highlight financial, social and management risks, quantifying the possible consequences in terms of increased time, costs and changes in the implementation of the action.

Risk analysis should include:

- a list of adverse events or negative factors to which the action is subjected;
- a risk matrix that reports for each adverse event the possible causes that originate the event, the negative effects that would occur on the action, the classification levels of the probability of occurrence (i.e. very unlikely, unlikely, as likely as unlikely, probable, very probable), the severity of the impact and the level of risk, i.e. the combination of probability and impact;
- the identification of prevention and mitigation measures;
- the assessment of residual risks after the implementation of prevention and mitigation measures; a description of the mitigation and prevention measures of the main risks.

Table 5 shows some examples of risk type and the connected adverse events.

*Table 5: Examples of risk type and connected adverse events*

<b>Risk type</b>	<b>Adverse event</b>
Normative	Changes in the regulatory framework Changes to environmental requirements
Transport Demand	Traffics other than those foreseen
Transport Supply	Evolution of technology Increase in management / implementation costs
Planning	Inadequacy of analyses Inadequacy of the design and estimates of cost
Administrative	Bureaucratic delays
Social	Opposition from public opinion

In the risk analysis, all possible negative issues that may affect the implementation of the action must be listed. It is not only related to risks, but also to disruptive trends such as new technologies that can change the perception or way of managing entire supply chains.

Finally, to monitor and evaluate an action, some key performance indicators (KPIs) are required. During the implementation phase it is the only way to evaluate the individual action and find countermeasures if things do not go as planned. It is advisable to define a few simple indicators that start from the definition of the baseline. Some of these indicators are explicitly applied and analysed in the paragraph 2.3 of this report.

## 5 CONCLUSIONS

This document aims to provide a methodology, guidelines and criteria for defining the technical, operational and technological conditions that make the port and its hinterland an efficient hub.

Specifically, the toolbox provides a clear definition of the port hinterland concept and proposes a series of analytical tools, based on transport and logistic considerations, to identify the dimensions of the hinterland of a port.

The toolbox also provides a set of qualitative and quantitative indicators for assessing the efficiency and effectiveness of the port-hinterland system, with particular attention to accessibility and mutual connectivity between port and its hinterland.

The toolbox contains a series of criteria that must be followed for the creation of an integrated and sustainable port-hinterland hub. The criteria concern 5 areas of application: infrastructures, operations, market, innovation and institutions.

Finally, the toolbox proposes an organic and structured methodology that is configured as a path to follow to activate the process of creating an integrated port-hinterland hub.

## BIBLIOGRAPHY

Ahn K. (2018). Port Community System. Capacity Building Workshop on Strengthening Integrated Intermodal Transport Connectivity for Southeast and South-Southwest Asia. Bangkok, Thailand, 9, March. 2018.

Arvis J.F., Vesin V., Carruthers R., Ducruet C., de Langen P. (2019). Maritime Networks, Port Efficiency, and Hinterland Connectivity in the Mediterranean. International Bank for Reconstruction and Development / The World Bank. ISBN 978-1-4648-1274-3.

Bergqvist R. (2012). Hinterland Logistics and Global Supply Chains. In Song D-W., Panayides P (eds.), *Maritime Logistics: a complete guide to effective shipping and port management*, pp. 211-230. Kogan Page London ISBN-10: 9780749463694

Deutsches Zentrum für Luft- und Raumfahrt- DLR (2017) *NGT CARGO: What freight trains of the future will look like* (<https://verkehrsforschung.dlr.de/en/projects/ngt-cargo>)

Dickenbrok, B., Jugelt, R., Schröder, J., Stuhr, H. (2009), FlexCargoRail - a contribution to increase efficiency in wagonload traffic. ZEV-Rail, Heft 1-2, 2009

Fageda, X. (2005). Load centres in the Mediterranean port range: Ports hub and ports gateway. Public Policies and Economic Regulation Research Unit, University of Barcelona.

Gattuso D., Cassone G.C. (2018). AGW for efficient freight transport in container yard. Supply models and costs. *Transportation Research Procedia*, Volume 31 (18), pp. 108-120.

Gattuso D., Cassone G.C., Ferraro G. (2009). Container Port Performance Indicators: a Methodological Approach. NAV 2009, 16th International Conference of Ship and Shipping Research (Vol.II, pp 158-166). 25th-26th November 2009. Messina. ISBN 978-88-904394-0-7

Gattuso D., Cassone G.C., Malara M. (2019). Performance Measures and Accessibility Analysis in Public Transport Networks. Conference on Transport Sciences “Challenges of the future: Alternative - Autonomous - Cooperative - Comparative mobility”. Gyor 2019, 21-22 March. ISBN 978-963-8121-86-8

Guthed, A. (2005). Port Hinterland Connections, Licentiate thesis, Division of Logistics and Transportation, Chalmers University of Technology, Gothenburg.

Himmelstein S. (2017). The Automated Freight Train of the Future (<https://insights.globalspec.com/article/4754/the-automated-freight-train-of-the-future>).

Hintjens J. (2018). A conceptual framework for cooperation in hinterland development between neighboring seaport authorities. *Maritime Policy & Management*, 45:6, 819-836, DOI: 10.1080/03088839.2018.1495343

Horst M., De Langen P. (2008). Coordination in hinterland transport chains: a major challenge for seaport communities. *Maritime Economic & Logistics*, 10(1-2), 108- 129. doi:10.1057/palgrave.mel.9100194.

Jeschke, S. (2011) Global Trends in Transport Routes and Goods Transport: Influence on Future International Loading Units, *Discussion Paper - 16th ACEA SAG Meeting - June 2011*

Keese S., Bernhart W., Dressler N., Baum M., Rentzsch W. (2016). Automated Trucks. The next big disruptor in the automotive industry?. Roland Berger Study. Chicago / Munich.

König, R., Hecht, M. (2012) *White paper Innovative rail freight wagon 2030. The “5L” future initiative as a basis for growth in rail freight transportation*. TU Dresden - Institute of Railway System, Public and Urban Transport and TU Berlin - Rail Vehicles Department

Lee, S.W., D.W. Song and C. Ducruet (2008) “A tale of Asia’s world ports: the spatial evolution in global hub port cities”, *Geoforum*, Vol. 39, pp. 373-385.

Malzacher, G., Böhm, M., Krüger, D., Winter, J. (2018) NGT CARGO - Intelligent Automated Rail Freight for the Next Generation. *RAILcph Conference 2018. Conference Paper*

Meng Q., Wang X., Miao L. (2013). Boundary Estimation of Probabilistic Port Hinterland for Intermodal Freight Transportation Operations. Selected proceedings WCTR 2013, Rio de Janeiro (Brazil). ISBN: 978-85-285-0232-9.

Merk O., Notteboom T. (2015). Port Hinterland Connectivity. International Transport Forum Discussion Papers. doi:10.1787/5jrvzrm4t724-en.

Montono. I., Furuichi. M., Kimoto, H., Suzuki, S., (2014), A new concept of off-dock container traffic control for heavily congested ports, The Fifth International Conference on Transportation and Logistics (T-LOG), Bangkok.

Notteboom T., Rodrigue J-P. (2007). Re-assessing port-hinterland relationships in the context of global supply chains. In: Wang, J, Notteboom, T, Olivier, D and Slack, B (eds). *Ports, Cities, and Global Supply Chains*. Ashgate: Aldershot. pp. 51-68.

Notteboom, T. (2002). The interdependence between liner shipping networks and intermodal networks. IAME, Panama City, Panama.

Pagano P. (2019). Port of the Future 5G and IoT: the experience in Livorno. 5G Italy - The Global Meeting. Rome, 4/12/2019.

Pagano P. (2019). Roadmap and Progress for the Implementation of C-ITS Services at the Port of Livorno. ETSI 10th ITS Workshop Sophia-Antipolis (F), March, 4 - 6, 2019.

Port System Authority of the Northern Tyrrhenian Sea (2018). Livorno Digital Port: tools and services for the port Community ([https://www.portaltotirreno.it/wp-content/uploads/2018/03/DOC-INN-BROCHURE-APL\\_7.pdf](https://www.portaltotirreno.it/wp-content/uploads/2018/03/DOC-INN-BROCHURE-APL_7.pdf)).



Port System Authority of the Northern Tyrrhenian Sea (2018). Nota sintetica piattaforma MONI.C.A. ([https://www.portialtotirreno.it/wp-content/uploads/2018/03/AP-CNIT-Nota-Sintetica-MONICA\\_0.pdf](https://www.portialtotirreno.it/wp-content/uploads/2018/03/AP-CNIT-Nota-Sintetica-MONICA_0.pdf))

Rodrigue J. P. (2017). The Geography of Transport Systems FOURTH EDITION. Routledge New York. ISBN 978-1138669574 (<https://transportgeography.org/>).

Slack B. (1993) Pawns in the game: ports in global transportation systems, *Growth and Change*, 24, 379-388.

van der Horst M. (2016). Coordination in Hinterland Chains. An institutional analysis of port-related transport. TRAIL Thesis Series no. T2016/19, the Netherlands Research School TRAIL. Delft University of Technology.

van Gompel, M. (2018) *Alstom: Autonomous train test in Netherlands includes object sensors*. RailFreight.com

van Klink, H. A. and G. van den Berg (1998) Gateways and Intermodalism, *Journal of Transport Geography*, 6,(1), 1-9.

Vanoutrive T.(2011). Automatically generated port hinterlands. ERSA 2011 CONGRESS, Barcelona. New Challenges for European Regions and Urban Areas in a Globalised World.

Visser J., Konings R., Pielage B., Wiegman B. (2007). A new hinterland transport concept for the port of Rotterdam: Organizational and/or technological challenges. Transportation Research Forum, 48th Annual Forum, 2007. Boston:TRF.

Wada, N., and Tsuchida, M., (2013), Improvement of port logistics in Nagoya port - (in Japanese), Ministry of Land, Infrastructure and Transport.