

## DELIVERABLE D.T3.6.2

---

### Action plan for multipurpose charging infrastructure for multimodal PT e-services in Parma's FUA

Project index number and acronym	CE1100 LOW-CARB
Lead partner	PP1 - Leipzig Transport Company (LVB)
Deliverable number and title	D.T3.6.2, Action plan for multipurpose charging infrastructure for multimodal PT e-services in Parma's FUA
Responsible partner(s) (PP name and number)	PP8 - TEP spa
Project website	<a href="http://www.interreg-central.eu/low-carb">www.interreg-central.eu/low-carb</a>
Delivery date	11/2020
Status	Final
Dissemination level	Project



## Document history of revisions

Date	Name	Action	Status
04/2020	Ana-Maria Baston, Rupprecht Consult	Structure and brief content description	Template
06/2020	Davide Mezzadri, TEP spa; Daniele Villani, TEP spa	Input to template	Draft
10/2020	Ana-Maria Baston, Rupprecht Consult	Finalisation of draft version	Final draft
10/2020	Wolfgang Backhaus, trolley:motion	Quality review and finalisation	Final

## Executive Summary

Parma is a medium-sized city that lays in the middle of the Pianura Padana, which is the most industrialized - and therefore polluted - area of Italy. The city is struggling with air pollution. The local administration is fighting this battle also by promoting public transport and reducing its impact over the environment to increase the quality of life for citizens.

For this reason, the LOW-CARB partner TEP spa has studied the chance to reduce the impact of public transport in Parma. Over the last years, the company has fostered the renewal of its fleet purchasing new trolleybuses, methane buses and low-emissions Euro 6 diesel buses. The trolleybuses represent the main investment of TEP in electromobility. However, this kind of vehicle is strongly linked to the overhead infrastructure. The new full-electric trolleybuses have a battery that allows only a limited autonomy outside the network. That is why TEP is evaluating the opportunity to commute an urban line served by diesel buses into a line served by electric buses. The action plan studies all the aspects to be considered when a transport operator decides to commute a line this way: which is the most suitable recharging system to allow the necessary autonomy? Which electric buses should we purchased? Which technology fits best our project? How much must we invest?

Therefore, TEP developed an action plan for the implementation of a multi-purpose charging infrastructure for a multimodal electric mobility service combining trolley-/e-bus services with shared electric cars services. This allows PP8 TEP to combine the existing electric infrastructure, e.g. used by trolleybuses for charging of e buses and electric cars.

Within the development of the action plan, a survey was conducted to get information of user acceptance in terms of electric PT and shared e-car services. To decide which bus model should be deployed two different battery/ charging versions were analysed and one bus model was tested under real conditions. Also, layouts of routes and charging stations were developed. Additional, next steps of stakeholder engagement were defined and the energy market conditions and their effect on the implementation investigated.

Finally, TEP spa developed a measure implementation plan including an upscaling scenario for the bus line 8, and how to turn this line into an electric bus line and provide a multi-purpose charging infrastructure which could also be used by other electric mobility modes like e-cars or e-bikes.



## NUTS region(s) concerned by the strategy (relevant NUTS level)

### 1. Functional urban area of Parma

Country (NUTS 0)	IT
Region (NUTS 2)	Emilia-Romagna
Sub-region (NUTS 3)	Parma (ITH52)

### 1. Introduction to area - analysis of mobility related challenges for public transport

- ✓ Description of the pilot area, mobility challenges in relation to public transport, goals and next steps towards action plan development

As part of a larger European context, Italian cities continuously push towards the innovation of transportation in their urban mobility plans, aiming at a future of low emission.

Replacing fossil fuel bus fleets with transportation systems that take advantage of renewable energy sources is a must if you want to travel the Low Carb road.

The SUMP (“Piano Urbano Mobilità Sostenibile” - Sustainable Urban Mobility Plan) of Parma analytically and proactively reports on the impact that local public transport has on the city.

The analyses carried out over the years between 2008 and 2013 show that the use of public transport within urban traffic has decreased, but it was also found that, traffic within the city centre has followed the same general trend. Furthermore, this could also be derived from the feedback of the discussion groups that were set up to share the stages of constructing the Parma SUMP with the main parties involved (residents, institutions, associations and stakeholders). In fact, it is essential to involve all the relevant parties in order to identify the different needs but which satisfy society as a whole.

Among its various objectives, SUMP has to promote and improve the response of the Local Public Transport System (LPT), and encourage residents to make use thereof through various macro actions:

- Increasing the restricted-traffic areas and decreasing requests for the passes to these areas
- Encouraging sustainable mobility (electric buses and trolleybuses)
- Punctually increasing services in areas where it is most need
- Increasing preferential lanes

The principal element consists in the clear commitment of SUMP to the criteria of sustainability.

The PAIR 2020 (“Piano Aria Integrato Regionale” - Integrated Regional Air Plan) requires that the objectives related to the air quality must be incorporated into the planning tools at each level (therefore also in the SUMP of each municipality) and one of the macro actions envisaged is “Promoting and optimizing the use of local and regional public transport” which includes renewal of the bus fleet as well as strengthening and renewing the LPT services available, thereby discouraging the use of private vehicles.

In order to define the main objectives of SUMP, the reference scenario (SR) was assessed, i.e. the current state of the infrastructures available and of those already financed, and compared with the alternative plan scenarios (SP), which conform exclusively to the PAIR 2020 objectives (the expansion of urban pedestrian areas, Limited Traffic Zones, bicycle paths and, at the same time, stimulating and promoting

public transport, mobility management policies, electric mobility and rationalization of urban distribution of goods).

In particular, the Parma SUMP has selected the SP2 alternative as the plan scenario, which, among others, supports a substantial investment in public transport and a significant boost to the development of electric mobility (public and private).

The main interventions related to the network and collective transport services provided for in SP2, refer to:

- the local public transport network. The common thread that characterizes the interventions concerning this matter, is aimed at making the services more attractive; this translates into the need for a review of the network and the qualification of the services offered.

In particular, among these:

- on the side of services and public transport vehicles, the introduction of new fast-charging electric vehicles is expected on line 8.
- supporting the development of electric mobility, in particular by intervening with:
  - o the drafting of a municipal electric mobility plan.

## 2. Development of a scenario for low-carbon mobility with electric buses and a multi-purpose charging infrastructure for Parma

Based on the plan to introduce new electric bus lines in Parma's FUA, TEP - supported by the City of Parma - analysed the potential for the multipurpose use of charging infrastructure for electric vehicles. Within the development of a scenario, a survey was conducted to gather information on users' acceptance in terms of electric PT and shared e-car services. To decide which bus model should be deployed, two different battery/ charging versions were analysed, and one bus model was tested under real conditions. Layouts of routes and charging stations were also developed. A bus line was identified that would be feasible for introducing an e-bus service.

### **Stakeholder Engagement**



Figure 1: Impression from regular meeting to discuss features of line, terminal, (re-)recharging network/usage

The coordination team for the implementation of this pilot action plan consisted of TEP, the local energy provider and the City of Parma, responsible for overseeing all activities related to the detailed planning and authorisation of the new bus line and the recharge modules and civil works for the recharging system at the hub and the depot. In terms of resources, the bus line required input from a PT planner, recruitment of a driver, and procurement of the electric buses. The recharge system hub and depot required input from external experts as well as PT and infrastructure planners.

For citizens or potential users' involvement, a survey was carried out to identify and analyse the need for more electric services, i.e. charging infrastructure, and a multi-purpose charging infrastructure being used for multimodal electric mobility trips, e.g. changing from shared e-cars to an electric bus at a terminal. The results of a survey of 221 potential users indicated that there is significant support for combining e-car charging and e-bus usage. In total, 95.9 % of respondents stated that they are in favor of such a project, while 74.2 % said that if they would have access to an electric vehicle, they would be keen on parking and using multimodal recharging stations to reach the city centre by bus. In line with this were the results that 7.7 % would still try to reach the city by car, while 18.1 % would reach the city centre by bus only if it were fueled by clean or renewable fuels.

From the analysis carried out on Parma's SUMP objective and passenger capacities' analysis, the conclusion was made to transfer the existing diesel bus line no. 8 into an electric bus line with charging hubs for multipurpose use at terminal stops.

Below is an image drafted for the SUMP, indicating the analysis carried out on the traffic during peak hours in Parma, with the route of line 8 in question superimposed; it highlights the movements of entry to and exit from the urban ring.

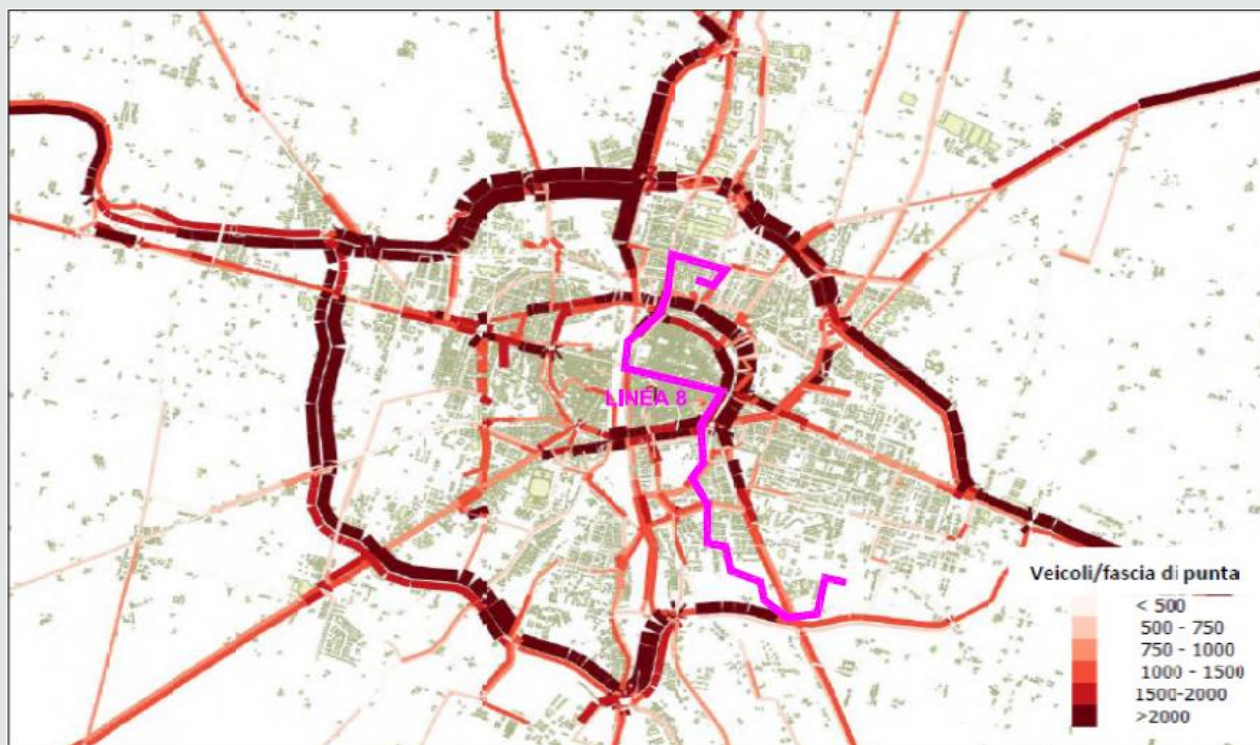

Figure 1: traffic flow on the road network of Parma - morning peak hour 7:30-9:00





The chosen line 8, as can be seen from the image, serves a section of the city that lies inside the ring roads, which passes along central roads with wide carriageways and not narrow historic portions of the city. The state of affairs drove the preliminary choice on medium-sized buses.

However, the fact that it does travel a long stretch through historic areas of the city prompted the choice of charging methods to fall on peripheral points, that is, the terminus and / or bus deposit of vehicles.

### 3. Development of the Action Plan

- 5.1. Introduction
- 5.2. Technical overview and battery charging
- 5.3. Definition of the characteristics of the system
- 5.4. Analysis of the energy consumption of different scenarios
- 5.5. Reorganisation and design of the terminus
- 5.6. Authorisations required for the new charging point
- 5.7. Analysis of the system at the bus depot for overnight recharging

#### 5.1. Introduction

Parma's PT operator, TEP, in cooperation with the City of Parma, developed an action plan for the implementation of multi-purpose charging infrastructure for a multimodal electric mobility service that combines electric bus services with shared electric car services. A key asset in this plan is the existing trolleybus network, which could become a backbone for electric charging infrastructure to introduce a new electric bus line and linked electromobility services. The existing trolleybus network consists of 21 vehicles that operate on 4 lines along 20 km of overhead catenary wires.

The plan foresees the implementation of an energy recovery system that includes a three-step energy flow: 1) recharging at the bus stop, 2) recharging at the bus depot, and 3) a kinetic energy recovery system. To this end, the following measures will be implemented: converting an existing diesel bus line to an electric bus line, building a recharge system hub, and building a depot for overnight recharging. By switching from diesel buses to electric buses, Parma will benefit from an estimated annual emissions reduction of 639.85 kg of CO<sub>2</sub>, 3,986.57 kg of NO<sub>x</sub> and 36.85 kg of PM<sub>10</sub>.

The action plan also includes:

- Identification of a new electrical line and transportation system program
- Technical overview and battery charging
- Definition of the characteristics of the system
- Analysis of the energy consumption of different scenarios (for line 8)
- Reorganisation and design of the terminus
- Authorisations required for the new charging point

- Analysis of the system at the bus depot for overnight recharging

## 5.2. Identification of a new electrical line and transportation system program

The choice of the vehicle and the technology to use was not easy, since there is no single standard on the market and each bus manufacturer offers different design solutions, often designed ad hoc, (battery capacity, speed of the charging system, converter on-board or external...) as well as charging systems (plug-in, with pantograph, slow or fast...).

The study started by evaluating the characteristics of the various devices that come into play in the system of means of transport and refuelling as a whole, which can be combined according to the specific needs of a city, but also of the transport line itself.

This topic will be detailed in later chapters.

This chapter deals with the overview of the main technologies available on the market which have been evaluated for their adaptability to the existing situation in the city of Parma and for the line chosen for the replacement of buses.

The main components that make up the "electric transport system" are:

- Buses
- Batteries
- Recharge Systems

### ***Buses***

For the choice of the means of transport suitable for the needs of the line and the city, the following characteristics were assessed:

- Length of the buses
- Capacity of seats for passengers dictated by the space taken up by the batteries due to their size
- On board or external converter
- Recharge with pantograph or plug-in

### ***Batteries***

Batteries are definitely the components that have the greatest impact on the cost of the entire system, as well as being the fastest evolving component in the search for achieving the best performance. The evolution of the reagents that make up the battery for electric vehicles shows the passage from:

- Lead
- Lithium ion
- Graphene

And the technologies that are still in the development phase



- Supercapacitors

Surely the characteristics to be evaluated to divert the choice are:

- The capacity
- The recharge speed

### ***Recharge system***

The performance of the charger is also crucial, as it affects the charging speed.

It can be integrated into the bus or set up externally.

The advantage of the external converter is without a doubt the fact that overall space inside the buses is recovered, consequent having an increase in the number of seats that can be approved; on the other hand, having the converter on board can be convenient when the line has been designed to recharge often along the route and therefore the cost of the infrastructure at the stop is reduced.

Each feature of the different components can be combined to find a solution that best suits the case being studied.

The factors to be evaluated are strictly interconnected and the evaluation of these factors is not immediately clear, a balance must be found according to the real needs that would optimize the final system as a whole of the case being studied:

- The size of the battery pack is strictly connected to the autonomy required; choosing to have large quantities of battery packs on board influences of the workload of the vehicle;
- Passenger transport capacity, strongly conditioned by the weight of the batteries and by the presence or absence of the converter on board, the right compromise will have to be assessed according to specific needs;
- Charging points at the bus deposit and re-evaluating the spaces available;
- Charging points, whether it is only at the terminus or located at various points along the route, which would allow a reduction of the battery pack on board but then constrain the routes;
- Power available for fast charging points as well as at the bus depot, which could result in the assessment of additional work for any increase in power if needed.

All these assessments involve a certain initial investment and a certain amount of energy saving and reduction of CO2 emissions in the environment. The final balance will be the subject of the subsequent chapters.

### **5.3. Definition of the characteristics of the system**

For the definition of the entire electric transport system, in such a way that it would be optimal for the case in question, a careful analysis of the needs of the chosen line was made: line 8.

The route of line 8 starts from an area which is fairly peripheral of the city and runs through a very central area, ending behind the railway station of Parma, for a total of about 10 kms one way (outbound).

The characteristics of the buses that piloted the market research were:





- Passenger transport capacity roughly equal to the current capacity
- Not equipped with pantograph on board (for the recharging characteristics necessary, described below)
- Batteries must have the capacity to carry out the entire daily schedule.

Based on these characteristics, a Solaris model, Urbino 12mt, was identified which has the following characteristics:

- Approved for about 80 passengers, similar to the CNG buses already in use in Parma;
- Two types of batteries
- High energy: total capacity 240 kWh (charging a bit slower 4 kWh / minute)
- High power: total capacity 145 kWh (faster charging 7.5 kWh / minute)
- Not equipped with a pantograph on board due to the difficulty of managing maintenance on various buses, but with an external pantograph recharging system plus a socket for slow recharging from the bus deposit.

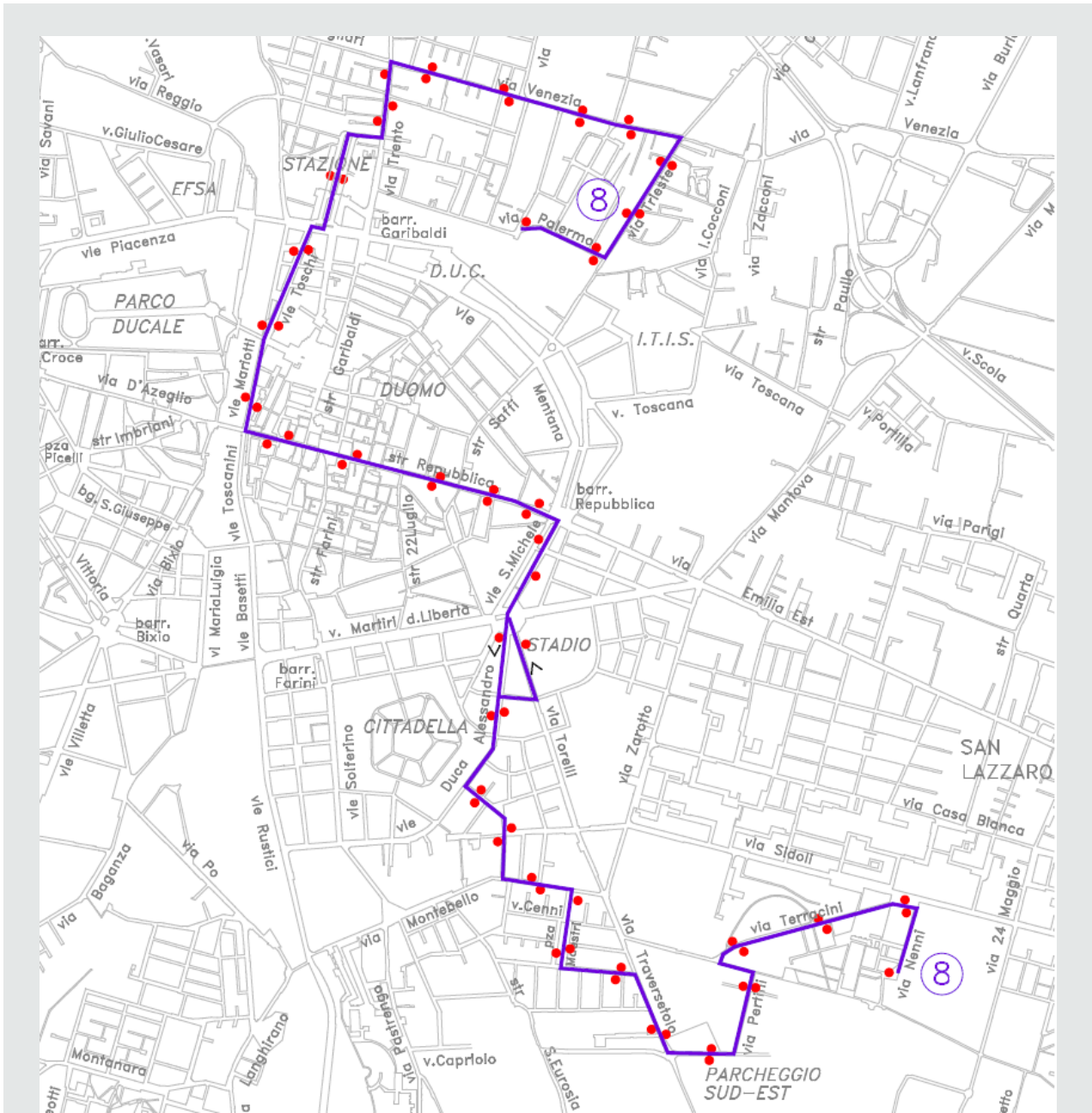

Figure 2: Presentation of bus line 8 route incl. bus stops

Type of battery	High Energy Battery	High Power Battery
Use	Suitable for vehicles that can be charged at the bus deposit and terminus	Suitable for vehicles with fast charging at the terminus and <b>mainly</b> for the Trolley buses (In Motion Charging)
Cycle duration	3300	14000
Maximum Storage (12 and 18 metres)	240 kWh (6 packs of 40 kWh)	145 kWh (5 packs of 29 kWh)



Recharge time	Slower than High Power as it has bigger storage capacity:	Faster than High Energy as it has smaller storage capacity:
	From deposit with 40 kWh charging station: 0.66 kW / minute; 6 hours to charge 240 kWh	From deposit with 40 kWh charging station: 0.66 kW / minute; 3,65 hours to charge 145 kWh
	From terminal with pantograph limited to 240 kWh: 4,0 kWh / minute.	From terminus with pantograph of 450 kWh: 7,5 kWh / minute.
Weight	Up to about 3000 kgs for a maximum storage of 240 kWh	<p>Weigh almost double that of High Energy Battery.</p> <p>Up to 3000 kgs for a maximum storage of 145 kWh</p>

Electric buses are able to take advantage of the energy generated when braking the vehicle through the electrodynamic braking system that uses the traction motor as a generator and can be activated when the brake pedal is pressed. This activation is also possible through the use of a 5-stage steering wheel lever.

The energy generated during the braking phase is recovered by the traction batteries, if they have suitable characteristics. In some cases, the batteries may not be able to collect all the energy (e.g. in the event of a battery system failure). In this case, a part of the energy is dissipated in the braking resistor mounted on the roof of the vehicle.

The characteristics required for fast charging (opportunity charge) were dictated by the following needs:

- Difficulty in installing various fast charging stations at intermediate stops due to the costs of civil works that are too high for the construction of the infrastructure and difficulties in obtaining authorizations in the city centre
- Possibility of having large space available at one of the two terminuses (Largo Nenni)
- Evaluation of a substantial initial investment and maintenance cost of the various pantographs over time.

Following these assessments, the most suitable recharging criterion was chosen, that would be the pantograph with recharging at the terminus.

The ABB system was identified that consists of a pantograph and modular sizing of the charging power.

## Opportunity charging

Reliable, scalable, based on industry standards



- Automated connection system
- High power DC transfer to bus
- Wireless communication to bus
- Based on
  - EN/IEC 61851-23
  - ISO/IEC 15118
- **OPR**charge compatible
- Industrial quality power cabinet
- 150kW, 300kW & 450 kW modular
- Redundancy per each 150kW module
- 200-920 V<sub>DC</sub>
- Galvanic isolation
- Remote management



Figure 3: Characteristics of the ABB opportunity charging system

### 5.4. Analysis of the energy consumption of different scenarios (for line 8)

Once the possible choices for the buses and fast charging points were defined, TEP made energy consumption calculations to evaluate the feasibility of the foreseen scenarios -in terms of energy needed for the electrification of line no. 8.

The one-way route is covered in 36 minutes and the stops at the terminus are 6 minutes:

time- [minutes]-x	route-x	stop-time-[minutes]-x	length-[Km]-x	speed-[Km/h]-x
36-x	via Palermo--via <u>Nenni</u> -x	6-x	9,46-x	15,8-x
36-x	via <u>Nenni</u> --via Palermo-x	6-x	9,46-x	15,8-x

Considering the timetable of the line and simulating the entire working day of a bus, the energy consumption graph is as follows:

Assumptions: The graph is compiled considering that the bus will start the day with the battery at its maximum capacity (see chapter regarding night-time charging at the deposit) and performing a quick charge at the Largo Nenni terminus at each return. This is the data entered relating to top-ups, considering an electricity consumption of 2 kWh/km (standard consumption figure for our type of use / route)).



Line	Maximum capacity (kWh)	Charge rate (kW/minute)	Total at terminal (kWh)	Charge remaining at the end of the day (kWh)	Minimum threshold for decline 30% (kWh)
high-energy	240	4	20	20	72
high-power	145	7,5	37,5	82,5	43,5

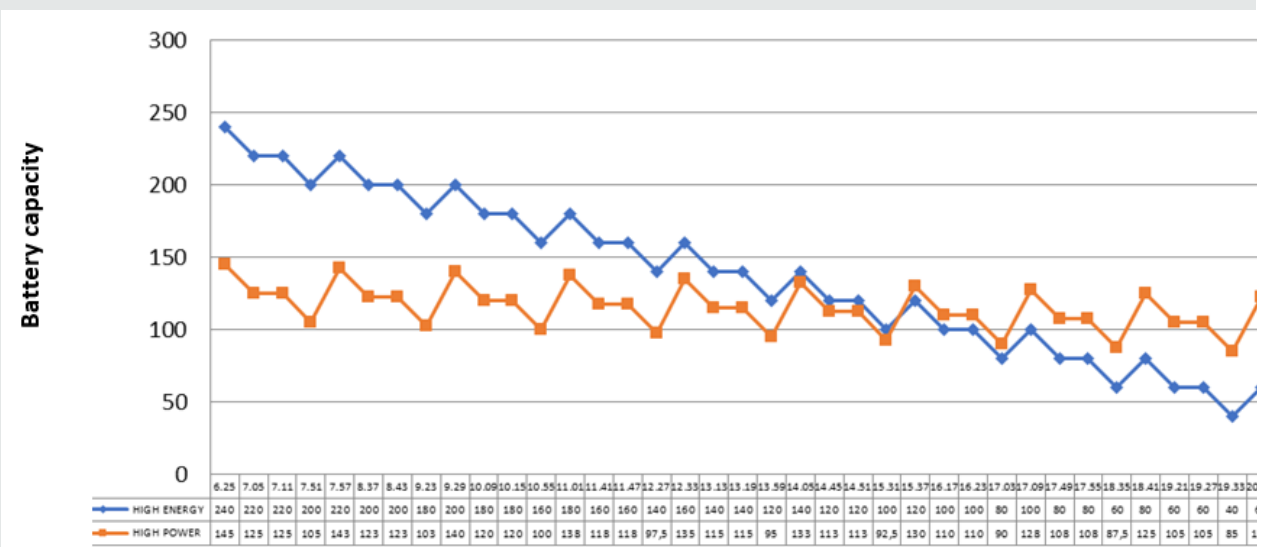

Figure 4: Consumption and recharge trend: typical day line 8

As can be seen from the result, despite the fact that the high energy type is more capacious, for the route in question, it is not efficient since slow recharging is not able to replenish the consumption made during a complete round trip, reducing the charge to a much lower level than the minimum recommended threshold to keep the battery efficient over the years.

Therefore, the best type of battery for line n. 8 is the High Power battery, 145 kWh and with a 37 kWh charge at the terminus in 5 minutes.

Having obtained this data, we are able to size the power required for the charging point at the terminus, considering 150 kW modules, the power need will be at least:

$$- 37 \text{ kWh} \cdot 60 / 5 = 444 \text{ kW}$$

Therefore, 3 power modules of 150 kW each is needed.

All this entails a re-evaluation of the spaces at the terminus, having to install, in addition to the complete charging system, an electrical substation as a delivery point on site, not having such availability near Largo Nenni.

### 5.5. Reorganization and design of the terminus

The figure below shows the current layout of the terminus at Largo Nenni:



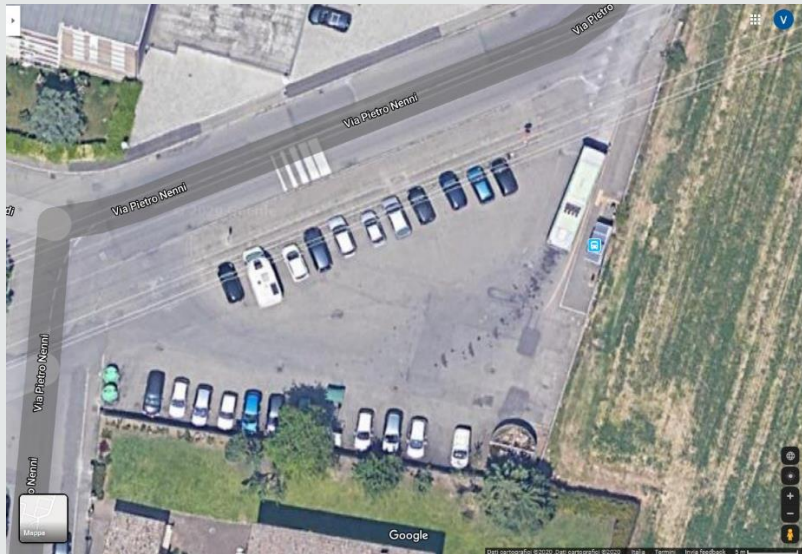

Figure 5: Current situation at terminus at Largo Nenni

The objectives to position are:

- **THE ELECTRICITY CABINET** for the power transformation, to be installed in a point where the required safety distance can be respected (minimum safety distance 4 meters)
- **THE PANTOGRAPH**, in an easily accessible position that allows the necessary manoeuvring for alignment of the bus;
- **THE RECHARGE MODULES**, to feed the pantograph

Furthermore, TEP would like to provide parking spaces with charging stations for users who reach the terminus with their own electric vehicles, to recharge them while parked.

The figure below shows the optimal final layout for the new equipment to be made available:

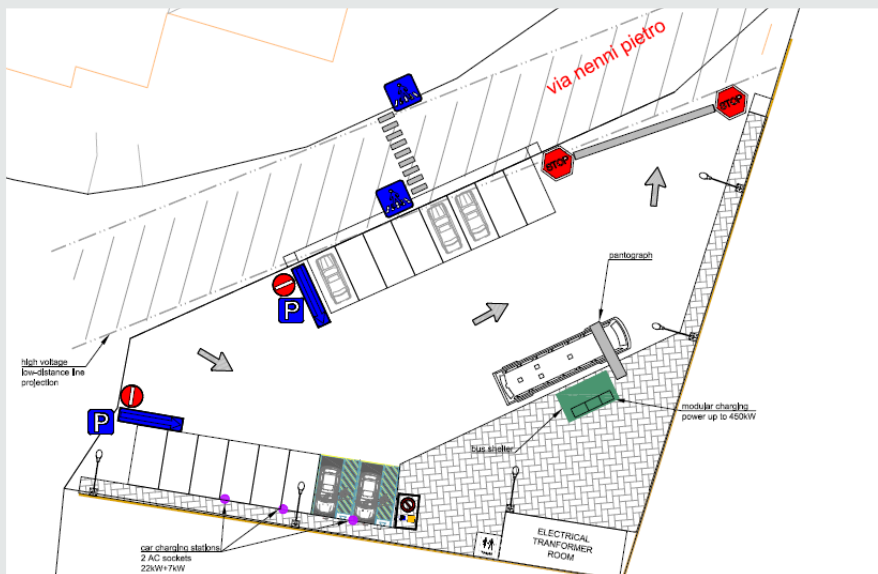

Figure 6: NEW MOBILITY HUBS: layout of the terminal at Largo Nenni

The selected pantograph and charging modules are items under the ABB brand and have the following technical characteristics:

**HVC-PD standard pole with ACS 150-450kW CE**



ABB standard pole with Automated Connection System (ACS) for charging 150-450kW. Includes:

**Standard pole:**

- Dimensions (W,D,H): 1060 x 4850 x 5520 mm
- Color: RAL 9003
- Weight: 1650 kg incl Pantograph and ACM

**Automated Connection Device (ACD):**

- Pantograph for automated charging of electric buses.
- Voltage range: 900V DC
- Max current: 600A
- weight: 165kg
- dimensions (W,D,H): 2010 mm x 900 mm x 490 mm
- Maximum inclination in bus driving direction: 2,5 degrees.

**Automated connection device Control Module (ACM):**

- Controls safety, pantograph movement and communications with the vehicle.
- Voltage range: 900V DC
- Max current: 600A
- Outdoor Wifi communication module
- Standard distance between HVC and ACS is max. 20 meters. Cabling between HVC and ACS is excluded.

Upgradeability: Upgrade to 600kW with additional costs is possible. Additional costs to be determined.

When 2 or more poles are positioned close to each other (<12m between center pantograph) the RFID antenna is required, see options below.

Figure 7: Technical parameters for pantograph (ABB)

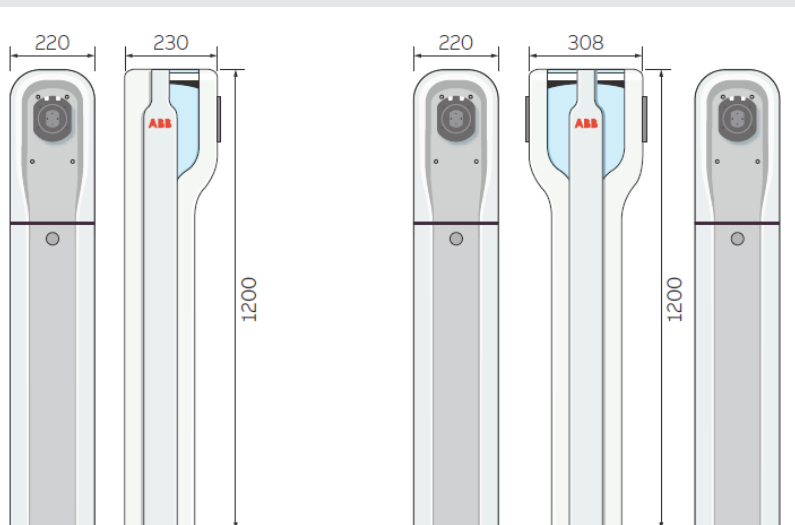

Figure 8: Possible solution for car charging stations with the characteristics defined for the project

**HVC 450PD CE**



**Heavy Vehicle Charger 450kW for charging with ACS (Automated Connection System excluded)**

- Opportunity charger for frequent, short duration charge sessions for DC charging with 4-pole Automatic Connection System (ACS) of electric buses (vehicle components excluded).
- DC output: 450kW; 150-850 VDC; max. 750A;
- Galvanic isolation.
- AC input: 3P + PE; 400 VAC +/-10% (50 Hz); 3 x 750 A, 519 kVA.
- CE certified; isolation resistance and DC output ripple current acc. to IEC 61851-23; EMC Class A acc. to IEC 61000-6-4 (emission) and IEC 61000-6-2 (immunity).
- DIN 70121 and OppCharge compatible.
- Controller, integrated 3G connection included.
- Operating temperature: -10 to + 50 deg C (down to -35 deg C with the option HxC robustness package).
- Dimensions: 770 (D) x 3510 (W) x 2030 (H) mm.
- Weight: 4020 kg.
- IP54, powder coated stainless steel housing for outdoor use.
- Standard DC cable length for connection to ACS: max. 20m (cable not included).
- Support of OCPP interface & ABB connected services.
- Upgradeable to 600 kW.
- Color: RAL 9002

Robustness package is recommended.

Figure 9: Technical parameters for charging modules (ABB)

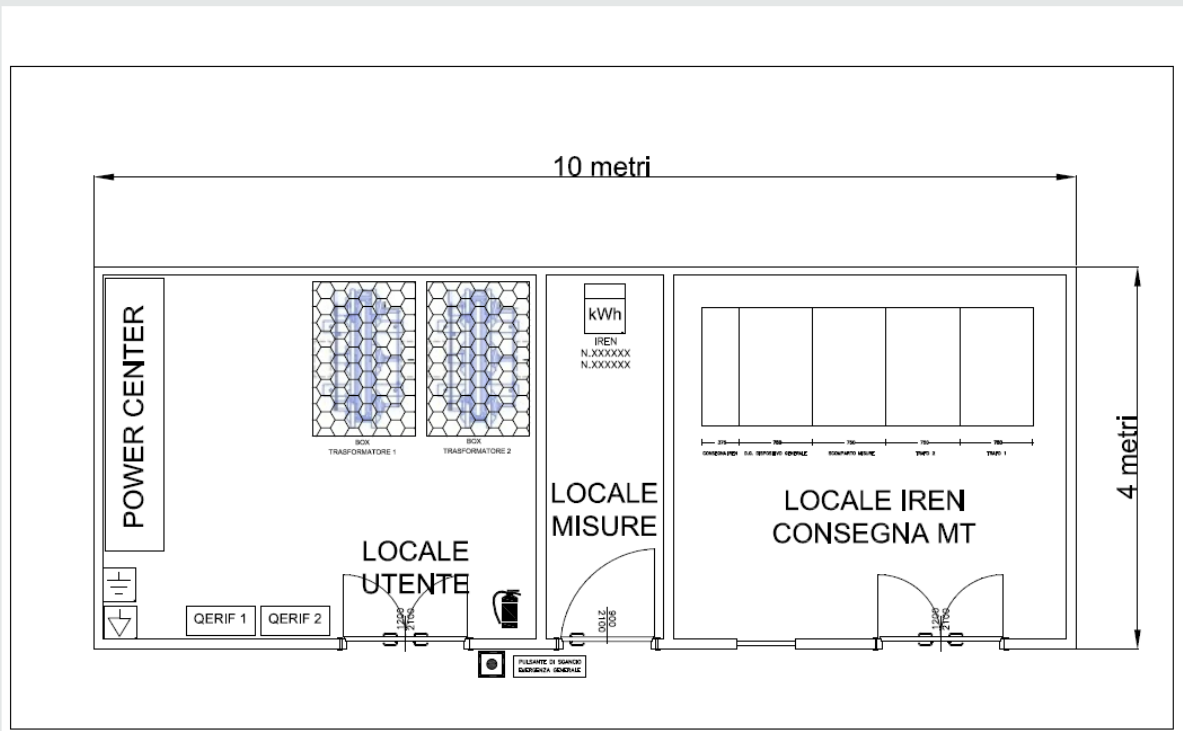

Figure 10: Cabin layout



**NEW MOBILITY HUBS: cabin layout MT/LV incl.:**

- 10 meters
- Power Centre
- User area
- Transformer box 1
- Transformer box 2
- Measurement area
- [above “IREN area MT delivery” text non legible]
- IREN area MT delivery
- 4 meters

The 10 m x 4 m cabinet is made up of three different areas:

- MV delivery area inside which the prefabricated MV switchboard with metal casing will be installed

Mechanical and Electrical Characteristics of the Q.MT	
Width	mm 900
Height	mm 1950 – 225.
Depth	mm 1150
Nominal Voltage	kV 24
Test Voltage for 1 min. 50 Hz	kV 50
Impulse Test Voltage	kV 125
Frequency	Hz 50-60
Nominal Current	A 630
Current End 1' sec	kA 16
Dynamic Current (in increase)	kA 40

- Measurement area where the counting meters will be located;
- User area with the two three-phase transformers with resin insulation, natural cooling (AN), in compliance with CEI 14-8 of 1999;
- the low voltage switchboard (power centre) located in the user area:

The switchboard will be made with a sendzimir sheet metal structure in compliance with UNI EN 10142 and closing panels (doors + side panels + rear panels) in cold laminate in compliance with UNI EN 10130 with a minimum thickness of no less than 15-20 / 10.



TECHNICAL CHARACTERISTICS OF THE TRANSFORMERS TR1 – TR2 / 15kV – 400/230Vac

- Resin insulation, MEC series
- Power 400 kVA
- V1=15 kV
- V2=400 kV
- Vcc=6%
- DYN11 Connection
- Frequency 50 Hz

INSTRUMENTATION

- Temperature probes
- 2-contact dial thermometer

The switchboard will be closed on each side with panels that can be removed with screws. The front doors will be equipped with a key lock.

The columns of the switchboard will be fixed with lifting eyebolts.

Slits will be provided on the front panel to allow for the passage of the control elements.

All the equipment will be fixed on Multifix guides or on panels fixed on specific support crosspieces.

The instruments and signalling lamps will be mounted on the front panels.

On the front panel each appliance will be marked with an indicator plate to identify its function.

All the metal parts of the switchboard will be earthed (in compliance with the provisions of the aforementioned CEI EN 60439-1 standard).

TECHNICAL CHARACTERISTICS Q.LV (PC)

Switchboard form 3

Degree of Protection IP30

Icc=20kA

Tension 400V/50Hz

Arrival from transformer with blind-compact 4x630A from above

Departure with cable from switch or terminal block

Fixed switches

Rear attachments

Auxiliary circuit voltage 220V / 50 Hz



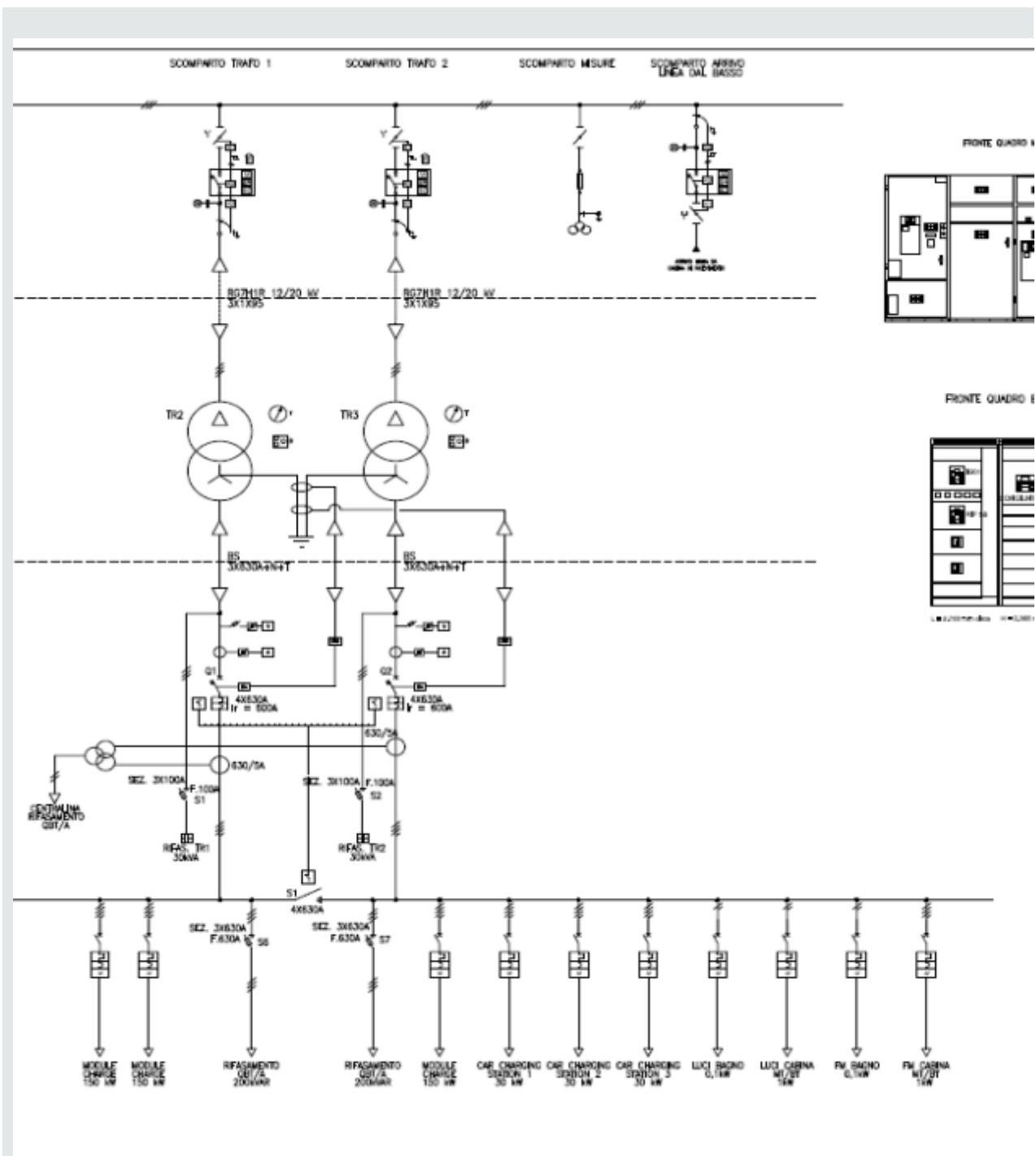

Figure 10: NEW MOBILITY HUBS: single-wire diagram for MV / LV cabine

This new provision involves the execution of civil works for the construction of:

- Excavations for the distribution of new electrical systems
- Excavations for the laying of the new electrical substation
- Excavations for the construction of a plumbing system to serve the bathroom with drinking water and connection to the sewer
- Construction of a new parking area / sidewalk to accommodate a new bus stop/bus shelter

- Reorganization of new parking spaces

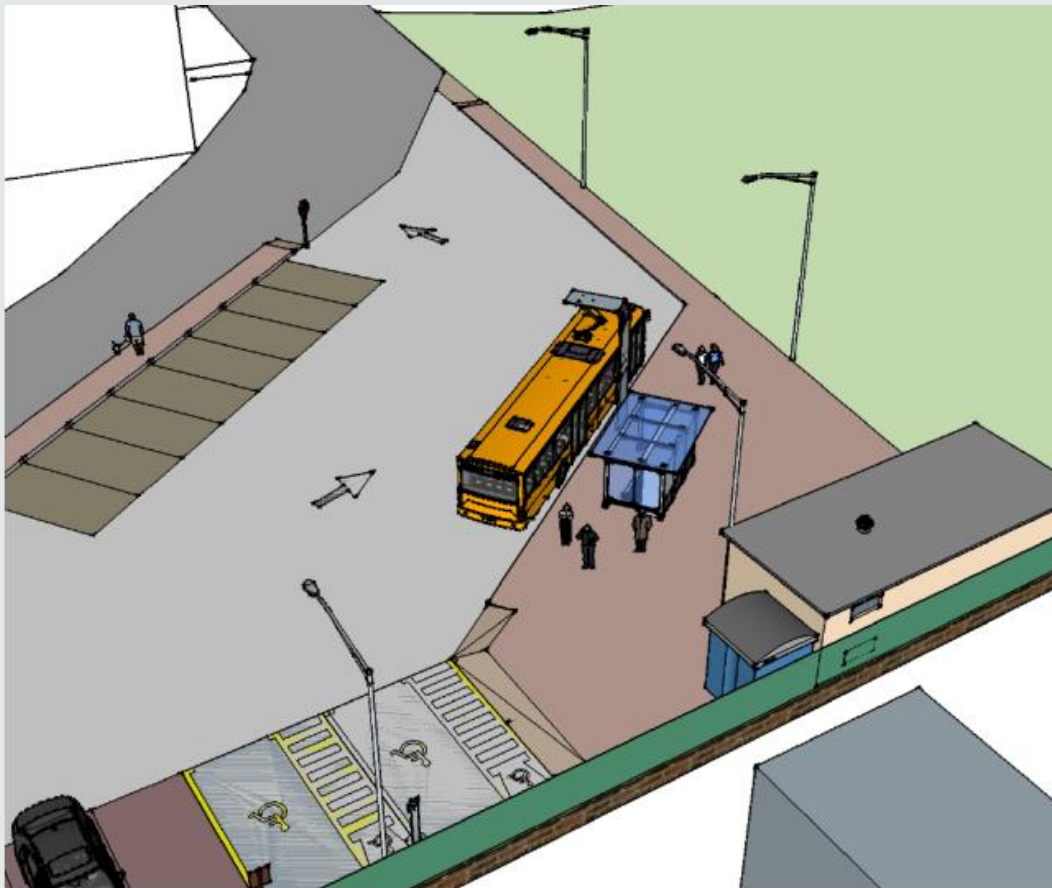

Figure 11: New terminus mobility hub scetch (rendered in 3D)

### 5.6. Authorizations required for the new charging point

The terminus of line 8 in Largo Nenni must be reorganized as shown in the previous chapters, with construction and plant engineering works to be carried out, therefore specific authorizations must be requested.

Authorization must be requested from public administration offices (municipal and / or provincial) for the necessary building permissions as well as permission from the public service distribution bodies (Iren, Enel, ...) for connections to plants and the for the creation of new distribution points.

Below is the list of documents to be submitted at the time of the authorization request, to be assessed and approved by the various bodies in charge.

#### **LIST OF GENERAL DOCUMENTATION FOR BUILDING AUTHORIZATION:**

- Doc C01: Title Request Form
- Doc C02: Asseverated Form
- Doc C03: General report
- Doc C04: RUE cartographic excerpt



- Doc C05: Photographic Documentation
- Doc C06: List of documents and elaborations
- Doc C07: Legalized Metric Calculation
- Doc C08: MUR A1.D1
- Doc C09: Copy of identity card of applicant
- Doc C10: Secretarial rights
  
- Table A01: altitude/plane-altimetric survey
- Table A02: general project plan
- Table A03: identification of type and quantity of areas to be transferred
- Table A04: dimensional specifications of the areas to be transferred
- Table A05: identification of road signs
- Table A06: road sections
- Table A07: type details
- Table A08: plans, elevations and sections of the artefacts

***LIST OF DOCUMENTATION AND PROCESSES FOR AUTHORIZATION OF THE SYSTEM:***

- Doc B01: general report
- Doc B02: black water sewage network: report
- Doc B03: white water sewerage: report
- Table B04: sewerage: planimetry
- Table B05: black water sewerage: profiles and details
- Table B06: white water sewerage: profiles and details
- Table B07: drinking water network: planimetry and details
- Table B08: electrical system network: planimetry
- Table B09: MV / LV single-line diagram network
- Table B10: Plan of MV / LV cabinet with details
- Table B11: public lighting system network: floor plan
- Table B12: electrical systems: details

The foreseen timing for the completion of the authorization procedures is lengthy, as there will be expropriations and various bodies involved will need to be consulted; about 6/8 months are expected to complete the process.

### 5.7. Analysis of the system at the bus depot for overnight recharge

The organization in the bus depot for overnight recharging is another aspect that foresees a reorganization of the spaces for the installation of the electrical recharging columns, of the distribution of electric energy with verification of availability of sufficient power, in addition to the analysis of the timing for the optimization of the available night-time.

The fleet of buses needed to cover the operating hours of line 8 is made up of 10 buses.

As described in the previous chapters, the assessment of the energy needs led to the choice of a 145-kWh capacity battery.

As could be seen from the graph that simulates the trend of the partial battery charges / discharges during the daily runs, the battery reaches the end of the day with a residual charge equal to ca. 80 kWh.

For overnight recharging, a solution from ABB was identified:

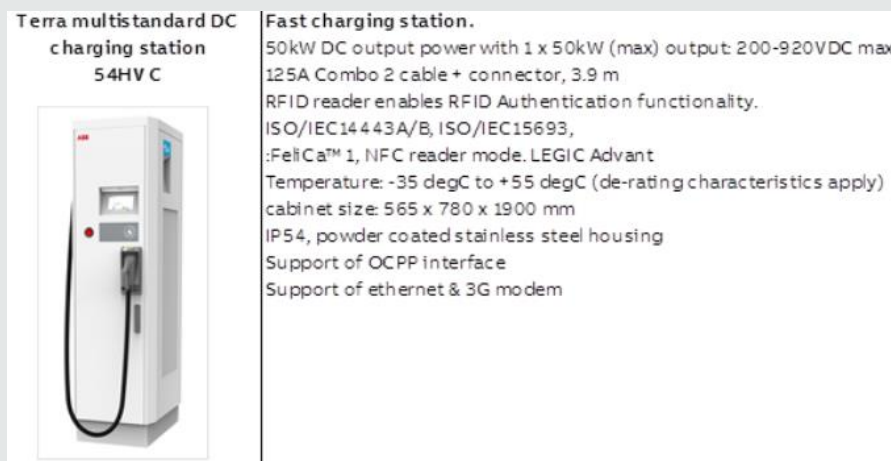

Figure 12: Technical data sheet for depot overnight recharging device

The charging speed of the Solaris Urbino bus at the depot, according to the technical data sheet, is 0.66 kW / minute; therefore, to recharge a bus the time needed will be:

- 145 kWh-80 kWh = 65 kWh => recharge time equal to 1h40min on charge

But for sizing we considered the worst-case scenario, which is that the battery is completely discharged (although for optimal use it must not be discharged more than 20% of its maximum capacity, and the on-board computer of the bus checks that this threshold is not exceeded).

With this hypothesis, the time to fully recharge each bus is about 3 hours. And for the complete overnight recharge of 10 buses, the requirement in terms of recharging columns is 4, with a recharge of 3 buses each and a partially occupied column, available for other vehicles.

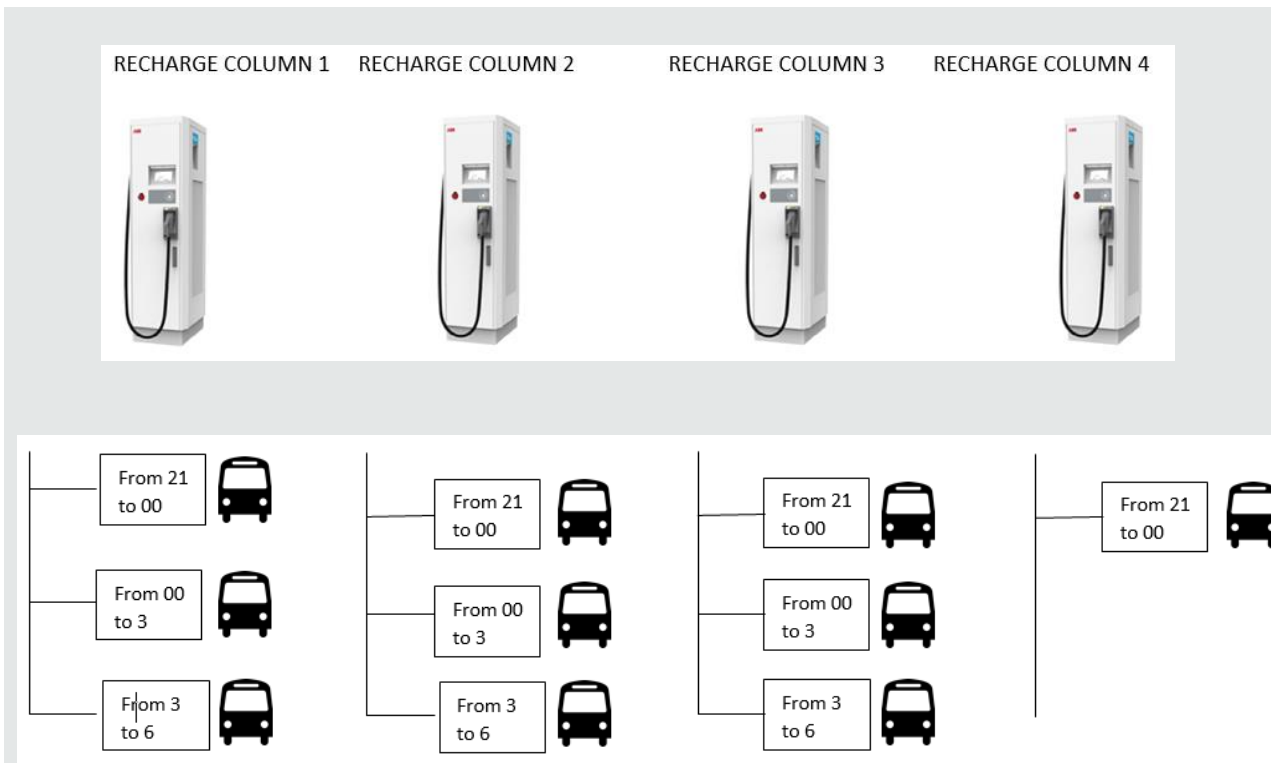

Figure 13: Arrangement and layout for overnight charging concept

Accordingly, there will be 200kW engaged and 125A max supplied, simultaneously, by each column for a total of 500A.

**5.8. Economic analysis of costs / benefits**

In conclusion, the project was developed around a fundamental element in the purchase of electric traction vehicles. Therefore, TEP tested an electric bus during the LOW-CARB project lifetime.





Figure 14: Impression from launch event for testing an electric bus from BYD (Buidl Your Dreams) in July 2019

During July 2019, TEP took the first Chinese e-bus manufactured in the EU to the roads and tested its energy consumption and approximate recharging times under different conditions (empty, with air-conditioning, etc.; see annex for more impressions). Media interest was high and during EUROPEAN MOBILITY WEEK in September, Parma's citizens were invited to share their views (for results of 'Line 8' tests, see above).

The design choices were guided by the performance required, based on:

- Route and orography of the line;
- Timetables / frequency of the line;
- Average and maximum daily trips;
- Transport system program (frequency of passing stops, stop times at the terminus)
- Location of any fast charging stations
- Location of the depot (distance from the line)
- Distance between stops
- Commercial speed
- Electric power available at the deposit and onboard recharging systems

Based on this data, the various choices on the market were assessed in order to further optimize costs and performance.

The final analysis below aims at providing the preliminary assessment of the economic aspects and environmental benefits of the intervention.



We started from an analysis of the initial costs relating to the transformation of line 8 from diesel to electric for:

- Cost of the Bus: € 420.000/each
- Cost of the pantograph: € 60.000
- Cost of the recharge modules at the terminus € 50.000/each
- Cost of the recharge columns at the deposit € 30.000/each
- Cost of the civil works at the terminus: € 20.000 per body

On the other hand, the purchase of a diesel bus involves an expense of around € 200,000 / each

This big difference on the initial expense is due to the battery pack that affects approximately € 240,000 for each bus.

To realise the electrification of line no. 8 the following investment of about 5 Mio. euros will be needed:

- 10 pantographs: 600 k euros;
- 3 recharge modules: 150 k euros;
- 4 recharge columns: 120 k euros;
- Civil works: 20 k euros;

Which amounts to a total of 890.000 euros in total for the investments to be made at terminus and depot. In addition, TEP spa will also need at least 10 electric buses to have the project in operation, that makes another 4,2 million euros to be added.

For calculating the comparison of consumption, the following was analysed:

- The number of daily trips, travel times, waiting times and the number of buses needed;
- The length of the route with its stops;
- The characteristics of the track;
- The expected consumption, electrical for the electric bus and diesel for the diesel bus;
- maintenance costs;
- The costs of changing battery packs after about 7 years of life.

That leads to a return on investment of about 26 years, a result which could be improved considering:

- the possibility of a lowering of the prices of batteries and improving their performance;
- the possibility of using the charging points on multiple urban lines.

In addition to the comparison on consumption, the savings in terms of polluting emissions into the atmosphere were also assessed, with environmental benefits that can be summarized as follows:

- CO<sub>2</sub> reduction of about 640 tons per year;
- NO<sub>x</sub> reduction of about 4 tons per year;
- PM 10 reduction of about 40 kg per year;
- Reduction of noise pollution;

The table below shows the results of the evaluations and basic assumptions / parameters:



### COMPARISON ON POLLUTING EMISSIONS

Total annual consumption (kWh)	10 1134000	Total annual consumption (l)	10 391230
Total emission of CO2 (0,35 kg/kWh)	396900	total CO2 emission (2,65 kg/l)	1036759,5
<b>SAVING CO2 TONS PER YEAR</b>		<b>639,85</b>	
NOx emissions from thermal power plant (0.48g / kWh) (*)	544320	urban bus NOx emissions between 15-18t (7,991g / km) (**)	4530897
<b>SAVINGS OF Kg OF NOx PER YEAR</b>		<b>3.986,57</b>	
PM10 emissions from thermal power plant (0.054g / kWh) (*)	61236	PM10 city bus emissions between 15-18t (0.173g / km) (**)	98091
<b>SAVINGS OF Kg OF PM PER YEAR</b>		<b>36,85</b>	

(\*) the value derives from an environmental report of ENEL S.p.A. based on its own thermoelectric power plants carried out in 2002. A reduction coefficient of 40% was applied, which corresponds to the percentage of renewable sources that the company declares as a contribution to the energy sold to customers.

(\*\*) Value deriving from a 2014 publication of Inemar Arpa Lombardia on polluting emissions from heavy public transport vehicles

#### 5.9. Outlook and upscaling - Parma's trolleybus network as a backbone to foster electric mobility

The imperative for local public transport in Europe and in Italy is the switch to electricity. TEP has decided to continue giving the trolleybus a leading role and plans to integrate the new electric buses that are more advanced and reliable technological in as much as being an upgrade from the trolleybus system. Focusing on electric traction means putting trolley buses and future battery electric buses at the centre of design and planning of the mobility in Parma.

The centre and strength of electric traction in Parma is in numbers: four trolley lines (amounting to 25% of our urban lines) on which 40% of urban users are transported.

Every day 21 trolley buses leave the TEP depot connected to a two-wire 650 V powered line by 5 substations with power installed from between 720 to 1750 KW. Each year the TEP trolley buses travel 1 MILLION km with a TOTAL consumption of 2 MILLION kWh.

The transformation to electricity involves the insertion of electric buses instead of diesel buses on line 8 with recharging at the terminus (bi-modal bus and car recharging).

The goal is to reach 1.5 MILLION km / year with electric buses (battery + trolleybus).

The next steps will be to conduct an analysis of trolleybus and e-bus systems to identify best practices for multipurpose charging infrastructure. The coordination team of TEP and the City of Parma will also work to align the implementation of the Action Plan closely with Parma’s Mobility Strategy.

The implementation of this action plan reveals the potential for new complementary e-mobility services in the future, which will provide residents and visitors in Parma with a wider range of attractive sustainable mobility options. The action plan therefore supports a continuous expansion of multimodal electromobility services in Parma’s FUA.

This also includes new mobility trends like sharing and micro-mobility. Parma’s trolleybus network could be a backbone for such multimodal offers, and trolleybus terminals and stops with substations nearby could link public transport to cycling infrastructure and sharing offers including a potential set-up of mobility hubs to create a seamless low-carbon mobility offer for Parma’s citizens or commuters.

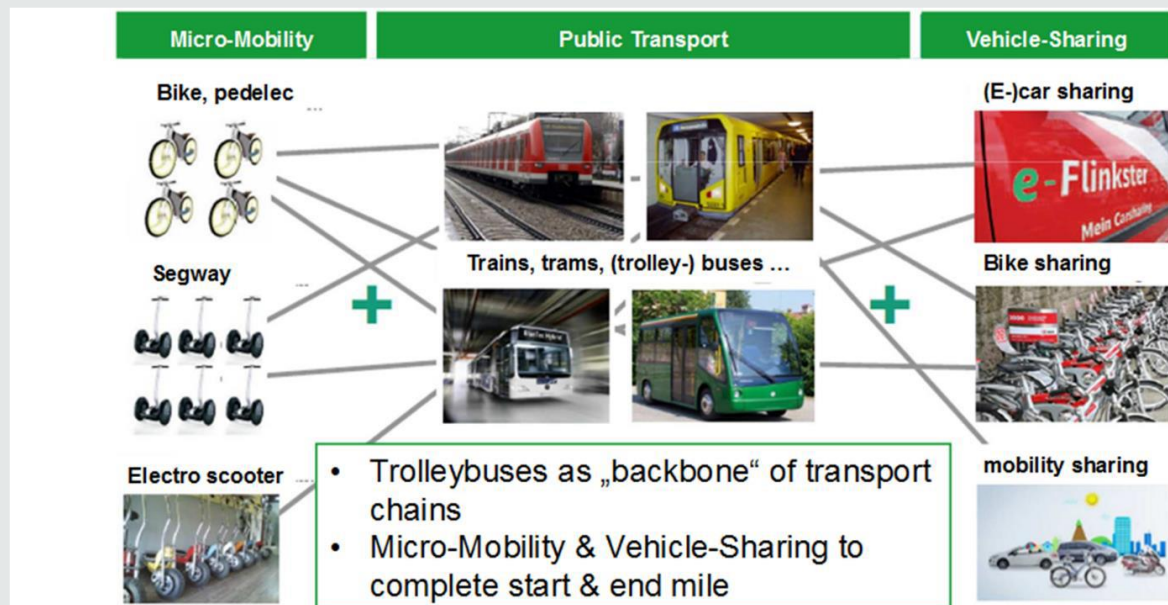

Figure 15: Scheme for public transport with trolleybus network as main backbone for seamless low-carbon mobility (source: Spath, IAO, 2001; revised by trolley:motion)

Potential further (e-)mobility hubs could be located at the edge of the urban area and the wider functional urban area:





Figure 16: Potential (e-)mobility hubs in Parma's road/transport network

The existing trolleybus network could be used to further electrify Parma's bus system, and to lower the financial risk associated with it, TEP could analyse potentials for an In-Motion-Charging (IMC) concept which would allow for the introduction of new trolley-battery bus lines by extending the trolleybus network without major infrastructure cost. The IMC concept implies the purchase of new battery-hybrid-trolleybuses, which could operate without overhead connection for about half of the line length and would be enabled to charge the battery in motion while connected to the overhead wire (see below figure 17 with basic IMC scheme and advantages of IMC systems). This concept could be realized along Parma's East-West axis - based on existing trolleybus infrastructure. Furthermore, new electric infrastructure deployment, like additional substations, would be necessary which could also be used for multipurpose charging options based on this new electric infrastructure (see below figure 19).

**COVERING 20 - 40% OF THE ROUTE BY OVERHEAD WIRES**

- Up to 80% is autonomous driving
- Trolleybus functionality In Motion Charging
- No need to stop for charging
- Efficiency and flexibility
- No extra vehicles and drivers required for operating In Motion Charging
- Smaller battery capacity and more passengers

- The infrastructure is not just less expensive per km, but also by 60% - 80% shorter
- Infrastructure investment less expensive than in case of standard trolleybus and much less in comparison to tram
- Overhead wires infrastructure simpler and cheaper than in standard trolleybus route since expensive and maintenance intensive switches, crossings and even some curves can get avoided
- Balanced energy demand of the vehicles with batteries leads to higher utilisation of infrastructure

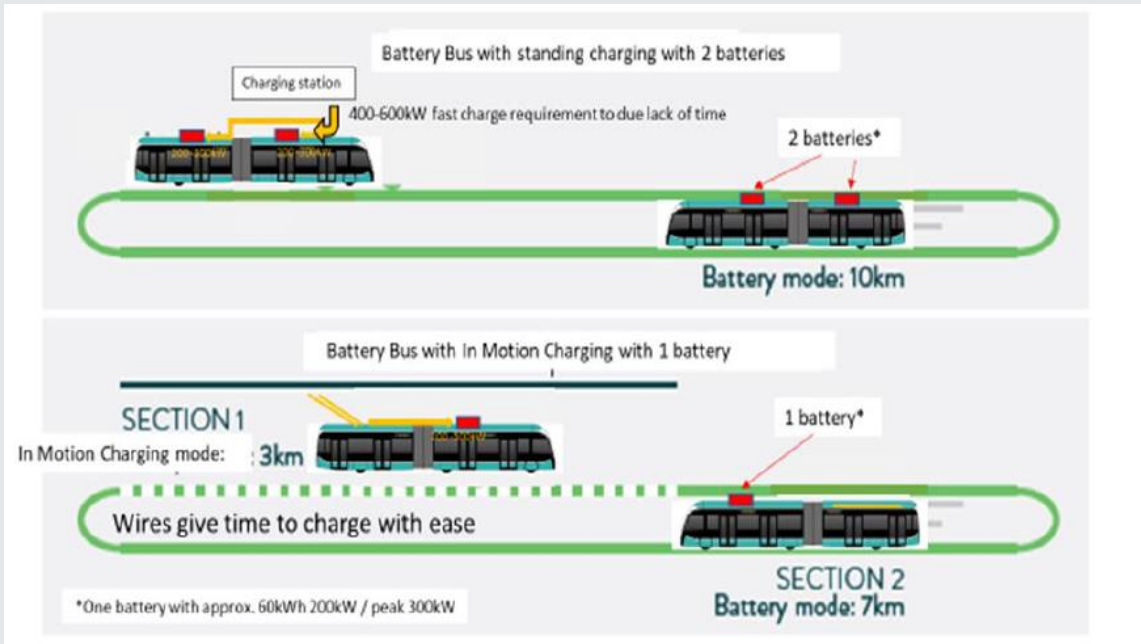

Figure 17: Basic concept of In-Motion-Charging (IMC) and main criteria/advantages (source, UITP 2019)

The IMC concept has established itself for trolleybus network extensions (e.g. Gdynia, PL, Solingen/ Esslingen, DE, Cagliari, IT, Pilsen, CZ, Arnhem, NL), and even new IMC-based networks are under discussion, e.g. Berlin, DE, Maribor, SL or Prague, CZ for the Central Europe area. One best-practice is the small community Eberswalde, DE, which started its IMC concept phase already in 2012 in the framework of the Central Europe Interreg project TROLLEY, in which the local public transport operator Barnim Bus Company (BBG) started its first battery-trolleybus pilot and tested this system for several years in terms of battery performance for off-wire operation. Meanwhile, BBG finalised a follow-up project TROLLEY 2.0 in the ERA-Net Electric Mobility Europe project, in which all 12 trolleybuses now have been retrofitted with a battery and a first diesel bus line was replaced by an IMC trolleybus line.

Best Practice Barnim Bus Company, Eberswalde, DE		Quick facts	
Regional trolleybus line incl. IMC		Residents	41,000
A feasibility study conducted in the ELIPTIC project has shown that it is feasible to convert existing diesel bus lines in Eberswalde to emission-free lines using hybrid trolleybuses. This business case describes the establishment of the 910 line as a hybrid trolleybus line that charges under the existing catenary in Eberswalde and services the neighboring city Finowfurt using only traction batteries. As a highly innovative approach to the electrification of inter-city public road transport, the business case focuses on gaining practical experiences and deriving key learnings for further development in Eberswalde and other cities that can use Eberswalde as precedent or best-practice example.		PT % of modal split	13%
		Trolleybus % of modal split	n/a
		Total trolleybus fleet	12
		t/o hybrid trolleybuses	8
		<b>Strategic environment &amp; goals</b>	
		<ul style="list-style-type: none"> <li>Zero-emission strategy in Barnim County (incl. emission reduction in PT)</li> </ul>	

Figure 18: Best-Practice BBG, Eberswalde for IMC realisation to replace existing diesel bus line with trolleybus operation - based on retrofitted battery-trolleybuses line (source, trolley:motion, 2020)



The existing electric public transport infrastructure, either the overhead wire, a sub-station or even an additional opportunity charger at the terminus of an IMC trolleybus line, can be designed as multipurpose charging hub for several electric vehicle types at a mobility station. The example below shows (figure 17) the usage of tram infrastructure in the German City Oberhausen for charging electric buses and e-cars, providing fast-charging spots for e-cars.

There are several advantages for such an approach (taken from ELIPTIC final project brochure, 2018):

- Potential for high power charging: When using the existing DC grid, it is possible to draw relatively high power due to available capacities in the usually over-dimensioned systems enabling the application of DC fast charging stations ( $\geq 50\text{kW}$ ). Therefore, vehicles can be charged in a relatively small amount of time.
- More efficient use of public transport grids: In case of over-dimensioned grid capacities or times of low energy demand of rail/trolley-bound traction energy (e.g. at night), surpluses can be used to charge other electric vehicles without requiring new infrastructure and costly grid extensions. Thus, additional consumers can increase receptivity and thereby increase the efficiency of the grid.
- Higher cost efficiency: In a lot of cases using the public transport grid can be more cost-effective than using the public distribution network to charge non-rail-bound electric vehicles.
- Less additional space requirements: Existing switchgears, converter transformers and rectifiers of public transport sub-stations can be used. Chargers can be placed in sub-stations with weather-proof conditions Less bureaucratic installation of charging points. Data (regarding grid connection etc.) can be accessed in-house and do not necessarily have to be requested elsewhere. Building permissions are unnecessary when land is owned by the public transport operator and determining sites for charging points can be done completely independently. This can highly reduce the regulatory burden for public transport operators.
- Potential to integrate different e-mobility services: Possibility to offer various e-mobility services in multimodal e-mobility hubs in order to also allow for e-mobile trip chains including energy provision for these e-vehicles.

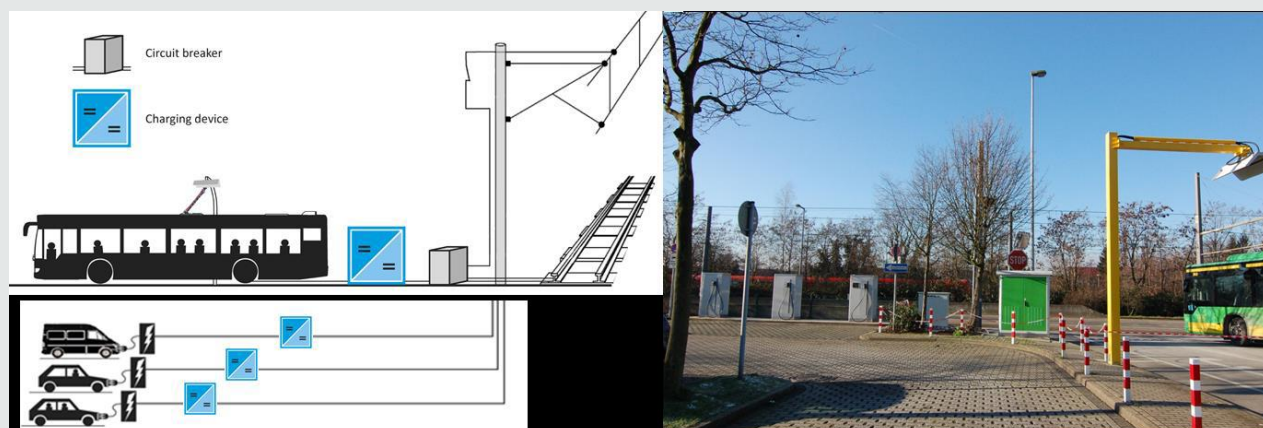

Figure 19: Basic scheme for using existing tram infrastructure for charging electric buses and e-cars (left); and “real” pilot in Oberhausen, DE, charging electric buses and e-cars based on tram infrastructure (source: ELIPTIC project, STOAG 2017)

However, there are still legal barriers due to current regulatory uncertainties in most European countries, as it is very difficult for public transport operators to resell energy to 3rd parties. Therefore,

it would be recommended to start with the charging of municipal or own (PT owned) fleets such as service cars or shared e-cars as an additional mobility offer of PT companies / municipal energy providers etc., as this does not involve any complicated metering and billing processes.

There are already few examples of e-car fast-chargers, powered by a DC trolley network across Europe. Ongoing tests with such devices to charge electric municipal fleets' vehicles are currently carried out in the Dutch trolleybus city Arnhem, where a DC charger prototype was integrated into the trolley network. The figures below show the basic scheme and a best practice example for such an integrated charging solution- based on the existing trolley infrastructure.

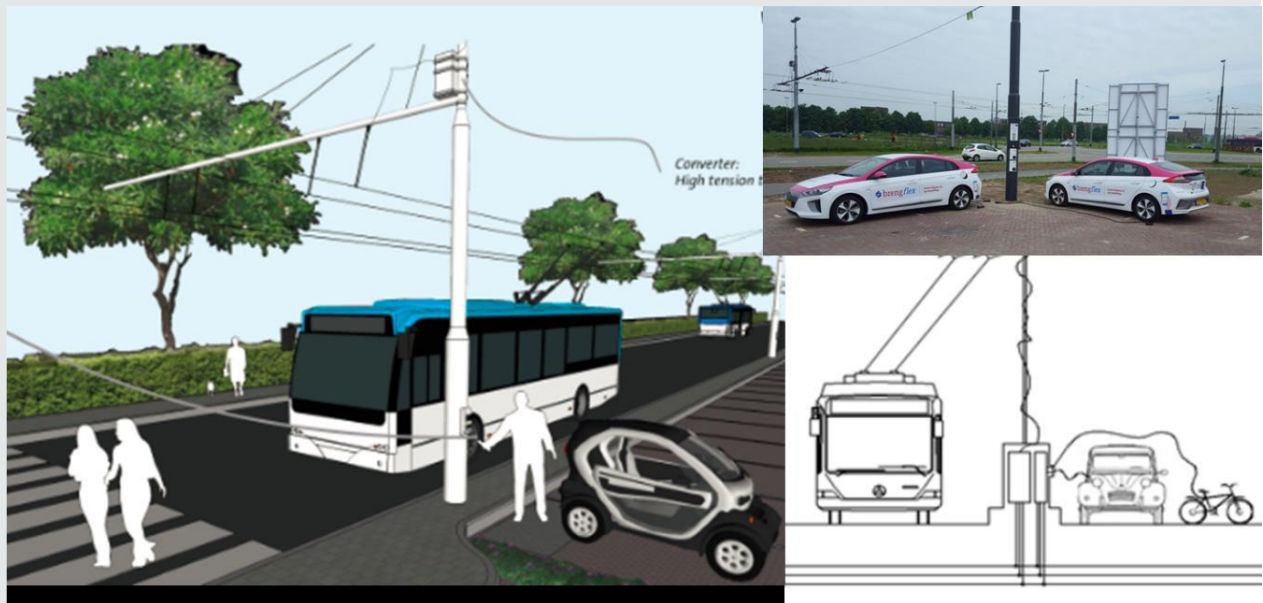

Figure 20: Basic scheme for using existing trolleybus infrastructure for charging e-cars (source: Connexion, ELIPTIC project, trolley:motion)

Best Practice Arnhem, NL	Quick facts	
<p><b>Multifunctional trolley grid incl. RES &amp; decentral SES</b></p> <p>The municipality of Arnhem has the ambition to be a global leader in trolley grid technology and be the world's first city with a truly smart trolley grid. Arnhem also wants to become an "energy city", for which a smart trolley grid is indispensable. These two ambitions come together within the trolley.2.0 project and demonstrating the potential of trolley grids to become DC backbones for battery-electric vehicle charging, integration of photovoltaic energy, brake energy recuperation for trolleybuses, as well as installation of stationary energy storage.</p> <p>In doing so, the business case focusses on advancing the theoretical model of the Arnhem trolleybus network, serving as an analytical basis for the implementation of a smart and multifunctional trolley grid in comparable cities.</p>	Residents	159,000
	PT % of modal split	10%
	Trolleybus % of modal split	10%
	Total trolleybus fleet	43
	t/o hybrid trolleybuses	2
<b>Strategic environment &amp; goals</b>		
<ul style="list-style-type: none"> <li>• Zero-emission public transport system in Arnhem</li> <li>• Build leading smart trolley grid</li> </ul>		



**DC-AC catenary solutions,** power solutions for charging machines for public transport cards, WiFi access points and dynamic travel information that's powered by the overhead contact line in Arnhem, NL

**DC-DC Charge solutions** for E-Mobility: e-car fast charger from the overhead contact line in Arnhem, NL



Figure 21: Best-Practice example for multi-purpose charging solutions based on trolleybus grid (source: trolley:motion, TROLLEY 2.0 project brochure 2020)

In addition, trolley-battery buses are considered as zero emission vehicle under the updated and revised Clean Vehicle Directive (EU 2019/116): According to the Directive, trolleybuses are considered to be zero-emission buses, provided that they run only on electricity or use only a zero-emission powertrain when not connected to the grid (i.e. battery equipped trolleybuses). Otherwise, they still count as clean vehicles. In countries where trolleybuses are classified as rail vehicles and not as road vehicles, the national implementation of the Directive would have to clarify whether trolleybuses count towards the procurement targets. The revised Clean Vehicles Directive requires Member States to ensure that minimum percentages of “clean” and “zero-emission” vehicles will be procured within two reference periods: the first phase from 2021-2025 and the second one from 2026-2030, which matches the given Action Plan time frame. For Italy, the quotas are 45% (2021-2025) and 65% (2026-2030), for both periods fifty percent of each quota will have to be fulfilled with zero-emission buses.

The Clean Vehicle Directive:

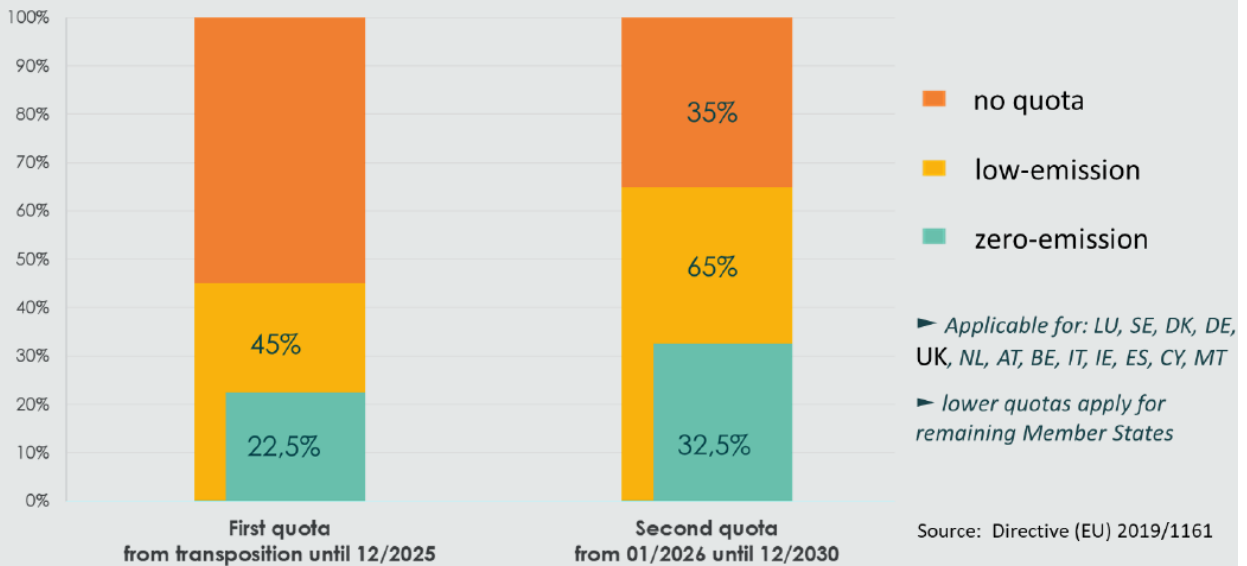

Figure 22: Clean Vehicle Directive quota for procurement of clean and zero-emission buses (source: UITP 2020)

Support for the deployment and financing of clean bus fleets provides the newly established Clean Bus Europe Platform (<https://cleanbusplatform.eu/about/the-platform>), which is an initiative under the European Commission’s Clean Bus Deployment Initiative that aims to support the deployment of clean bus technologies across Europe. The Platform brings together European cities, transport authorities and operators, together with relevant stakeholders like social dialogue partners, industry, financing and funding institutions, associations, etc. to boost and support the exchange of knowledge and expertise on clean bus deployment.

## 6. Conclusions



The action plan lays a concrete basis to implement the new e-bus line no. 8 in Parma. From an environmental perspective, the action plan shows that the differences of serving the line with diesel buses and with electric buses fueled by recharging stations at the terminal/depot in terms of polluting emissions are quite positive to realise low-carbon mobility services for Parma's FUA..

The new electric bus line no. 8 would reduce the CO2 emissions by ca. 640 tons per year. In addition, the NOx emissions would be cut by 3.986,57 kg per year, and the PM emissions by 36,85 kg per year. There would also be further benefits such as the reduction of noise pollution. The terminal could become a new exchanging car park, providing recharging facilities also for private e-vehicles.

From an economic point of view, the return on investment will require about 26 years, which is quite much. However, this result could be improved thanks to price reduction of batteries and to the possible improvement of their performance in the next few years. Moreover, usage of the charging points on several urban lines could increase the efficiency of the investment. The action plan has been thought for the electrification of the urban line n. 8 in Parma, considering the specific requirements of the Italian laws, but the project explains the steps to be done and the things that must be considered when a public transportation company decides to consider the idea of integrating an electric bus line recharged at the terminal in its network, and is, thus, replicable. In addition, Parma's existing trolleybus network infrastructure provides a basis for further electrification of bus lines and for providing DC-fast-charging points for other e-vehicle types.

Further key take-aways are:

- Experimenting with vehicles and technologies allowed TEP to gather useful data for future investment decisions;
- Joint planning of TEP and the City of Parma for electric mobility charging infrastructure and electric vehicles increased the perception of TEP as a company committed to sustainability;
- Cooperation with the municipality and with citizens increased the quality and acceptance of the action plan.



© G.Fantuzzi-fotoglamourparma.com

Figure 15: Trolleybus in Parma - backbone for Parma's electric public transport path

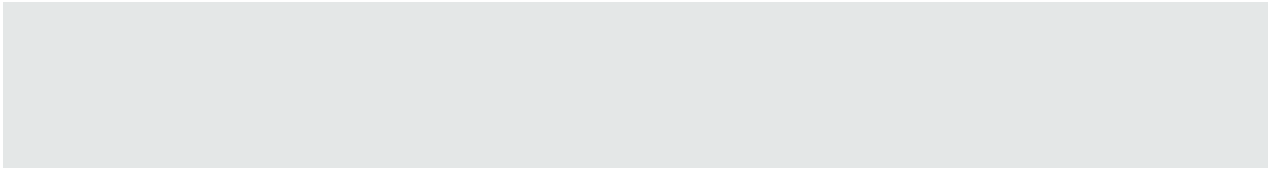

## 7. Annexes (if applicable, images or maps to be provided as annex)

*More impressions from 3D-rendered terminus:*

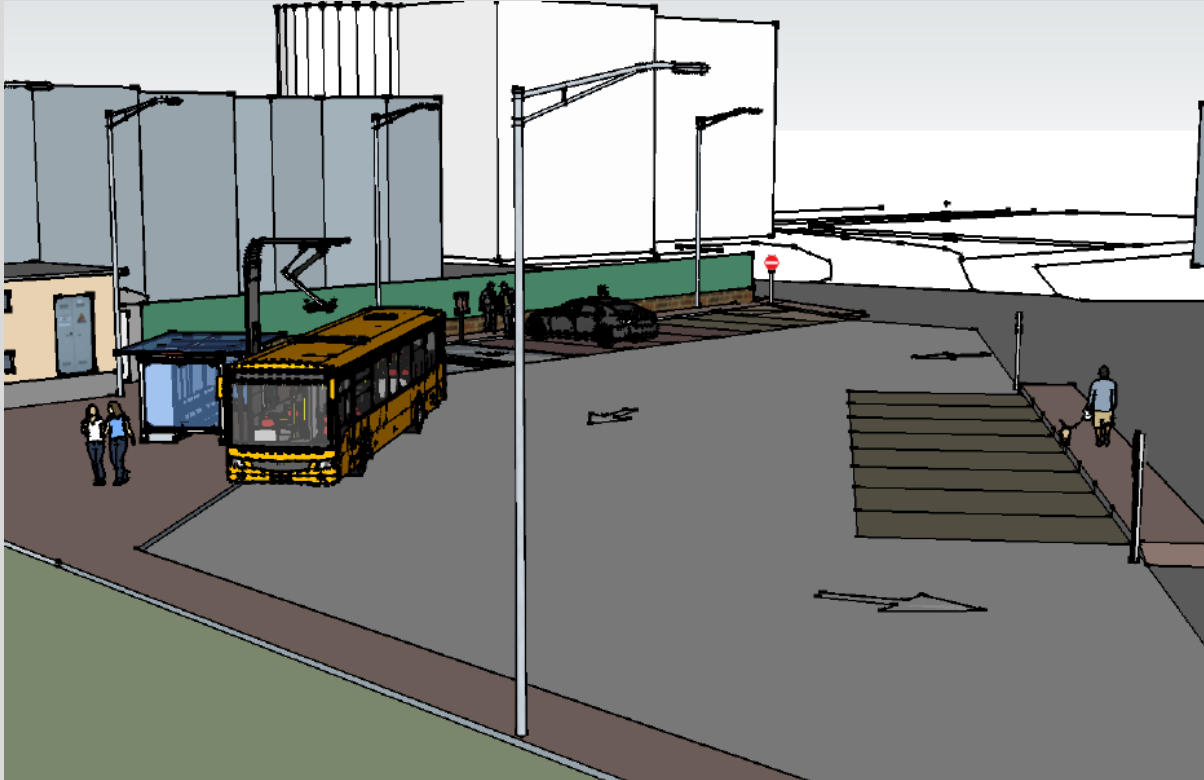

Figure 16: Terminus scetch rendered in 3D

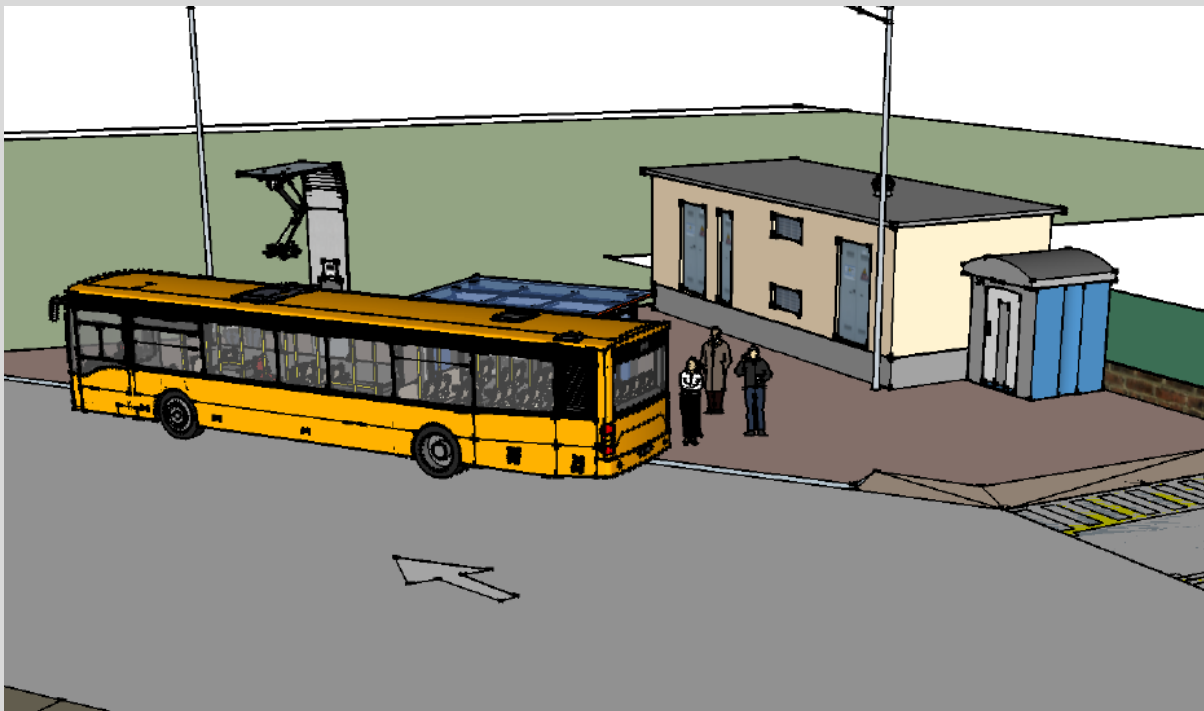

Figure 17: Terminus scetch rendered in 3D





Impressions from national trolleybus day training & presentation of line no. 8 electrification plans:

1st training: national trolleybus day

**GAZZETTA DI PARMA**  
12 | SABATO 6 APRILE 2020  
PARMA

**Filobus Prada: «Parma è all'avanguardia in Italia»**

L'annuncio: in arrivo nel 2020 dieci nuovi mezzi full-electric

**VITTORIO BOVELO**

«Il destino? Un veicolo così moderno ancora all'anno, ma che può avere un ruolo pieno in futuro. Il paese degli esperti di recupero e archivi progetti da Parma, una delle società italiane che si chiama Baxardo e altri...»

**PRIMA PAGINA DEL QUOTIDIANO GAZZETTA DI PARMA**



TAKING COOPERATION FORWARD

Figure 18: Impressions from national trolleybus day training

1st training: national trolleybus day



	[MJ/km]
Autobus	15.3
Filobus	7.5

silenzioso, comodo, confortevole

TAKING COOPERATION FORWARD



TAKING COOPERATION FORWARD

Figure 19: Impressions from national trolleybus day training

*Impressions from electric bus testing (BYD, 07/2019-09/2019) in Parma:*



*Figure 20: Impressions from electric bus testing (BYD, 07/2019-09/2019)*



*Figure 21: Impressions from electric bus testing (BYD, 07/2019-09/2019)*





Figure 22: Impressions from electric bus testing (BYD, 07/2019-09/2019)





**Annex:**

Technical characteristics for ABB charging module

Scope	Public / Private
Product Code	1SLM202200A3210
Charging Method	Method 3
Nr of sockets	2
Type of socket	2 x Type 2 lockable
Power output	2 x 22 kW
Lower manual power setting	2 x 11 kW
Current / voltage	32 A / 400 V
Charge	Tri-phase
Current regulation	16 A – 32 A (manual)
IP degree	IP54
Temperature	-30 +50 °C
Impact protection	IK10
General section with release coil for openings in case of contactor failure	-
Differential	Type B
Display	LCD 20x2
Led	RGB
Energy meter (single-phase impulse / three-phase digital and ModBus)	-
RFID Reader	MiFare(1)
Noise filters	-
Weight (kg)	25