



Usage of Class D/S Amplifier

– E&I amplifier as alternative for MF R/DGNSS-Mode transmissions –

Issue: 1.0
Issue Status: Approved
Issue Date: 02.09.2020

	Name	Partner	Signature
Provided	Lead Author	Michael Hoppe, WSV	
Review	Work Package Leader	Stefan Gewies, DLR	
Approval	Project Manager	Stefan Gewies, DLR	

Document Information

Project Title	R-Mode Baltic
Work Package No.	WP 5 / GA 5.2
Document Title	Usage of Class D/S Amplifier – E&I amplifier as alternative for MF R/DGNSS-Mode transmissions –
Description	This documents will report about measurements on a new D/S class amplifier for the usage of MF transmissions containing DGNSS and R-Mode signals
Date	02/09/2020
Lead Author	Michael Hoppe
Lead Author's Contact Information	German Federal Waterways and Shipping Administration (WSV) Telephone: +49 261 9819 2221 E-mail: Michael.Hoppe@wsv.bund.de
Contributing Author(s)	Lars Grundhöfer, DLR
Approval	02/09/2020

Track Changes

Issue	Date	Pages	Change	Author, Company
1.0	02/09/2020		First Version	M. Hoppe, WSV

This report was created within the framework of the **R-Mode Baltic** project, which aims to develop and demonstrate a new maritime backup system for Position, Navigation and Time (PNT) purposes based on R-Mode technology. Within the project life time of three years the project consortium develops solutions for R-Mode transmitter and receiver prototypes, for independent time synchronisations of broadcasting stations and for a testbed concept and its deployment. The dissemination of R-Mode technology is supported by work in international standardisation bodies. The world's first operational testbed for a transnational R-Mode system will be completed by the project in 2020.

The R-Mode Baltic project is co-financed by the European Regional Development Fund within the Interreg Baltic Sea Region Programme.



Executive Summary

This document provides results of a short measurement campaign to assess the use of a class d/s amplifier from E&I for the use of R-Mode and DGNSS transmissions in the MF radio beacon band (283.5-325.0 kHz).

Based on various measurements in the FVT-Lab, the DGNSS/R-Mode site in Zeven as well as measurements at the DGNSS site in Koblenz the E&I power amplifier, Typ 500S06 RF can be used for R-Mode and DGNSS transmitters without any measured in- and outband interference. Further it was shown that the E&I power amplifier can be used with the German MF transmitting antennas and that legacy DGNSS receivers could be used without any measured degradation.



Contents

1	Background	8
2	The E&I Amplifier.....	9
3	Measurements	10
3.1	General Setup	10
3.2	Lab Measurements.....	11
3.2.1	Setup	11
3.2.2	<i>Measurements</i>	11
3.3	Measurements at R-Mode/DGNSS site in Zeven	12
3.3.1	Setup	12
3.3.2	<i>Measurements</i>	13
3.4	Measurements at R-Mode/DGNSS site in Koblenz.....	17
3.4.1	Setup	17
3.4.2	<i>Measurements</i>	18
4	References.....	20



List of Figures

Figure 1: Power spectrum of the R-Mode/DGNSS modulator output signal	10
Figure 2 Setup for the Koblenz lab test.....	11
Figure 3 Setup for the Zeven test	12
Figure 4 Picture of the setup for the Zeven test	13
Figure 5: R-Mode/MSK modulator Oscilloscope for power monitoring.....	14
Figure 6 Power spectrum recorded on the PR 100	15
Figure 7: Power spectrum measured with the DLR R-Mode receiver.....	16
Figure 8: Phase measurement CW1, CW2 with the DLR R-Mode receiver.....	16
Figure 9 Setup for the Koblenz DGNSS test.....	17
Figure 10 Typical R-Mode/DGNSS site in Germany Left: Amplidan 200W MF transmitter class A/B Right: System rack with modulator clock and VRS based DGNSS equipment	18
Figure 11 Typical MF antenna used on German R-Mode/DGNSS sites (Typ NTA, Koblenz DGNSS).....	19
Figure 12 Power spectrum recorded on the PR 100	20

List of Tables

Table 1: Specification of E&I 500S06 RF power amplifier	9
---	---

Abbreviations

ACCSEAS	-	Accessibility for Shipping, Efficiency Advantages and Sustainability
AIS	-	Automatic Identification System
ATU	-	Antenna Tuning Unit
CW	-	Continuous Wave
DGNSS	-	Differential GNSS
EU	-	European Union
FVT	-	Fachstelle der WSV für Verkehrstechniken
GNSS	-	Global Navigation Satellite System
GPS	-	Global Positioning System – GNSS provided by USA
MF	-	Medium Frequency
MSK	-	Minimum Shift Keying
NTA	-	New Technology Antenna
RF	-	Radio Frequency
R-Mode	-	Ranging Mode
VDES	-	VHF Data Exchange System
VRS	-	Virtual reference Station

1 Background

R-Mode is a potential candidate to provide backup positioning to GNSS in the maritime field. The basic idea is to provide synchronized and precise timing using transmissions within the radio beacon band (283.5-325 kHz) or using VHF (AIS or VDES).

Main work about R-Mode was developed in a feasibility study, performed during the EU-ACCSEAS project (2012-2015), [1], [2]. These reports summarize a variety of potential ideas and solutions to implement R-Mode using MF DGNSS and AIS transmissions.

R-Mode Baltic is an EU-Project (2017-2020) aiming to establish a larger testbed for MF and VHF R-Mode in the Baltic Seas Area. For the MF test bed up to 9 MF radio beacon sites, currently used for DGPS transmissions will be modified to enable R-Mode.

For this purpose various installations needs to be adopted with respect to the existing MF amplifiers and MF antennas.

Most of the existing radio beacon transmitters are using old fashioned and inefficient class A/B transmitters which provide a linear amplification and could therefore easily used for R-Mode and DGNSS transmissions. Other service providers are using more efficient class D amplifiers which are normally not able to provide the combined R-Mode/DGNSS-Signal without in- and out band interference.

This brief report will inform about measurements with the S-Series RF power amplifier (Class D/S), from Electronics & Innovation, Ltd., for a possible future use of such transmitters for MF R-Mode/DGNSS- transmissions.

2 The E&I Amplifier

Electronics & Innovation, Ltd. Provided a highly efficient S-series RF power amplifier with sample ports. The 500S06 produces 500 Watts of power over a frequency range of 20 to 400 KHz, with a nominal power gain of 60 dB. The specification of the 500S06 RF power amplifier is as following [3]:

500S06 Specifications	
Class of Operation:	Class D/S
Frequency Coverage:	20 KHz – 600 KHz
Rated Power:	500 Watts into 50 Ω
Power Gain:	57 dB nominal
Gain Flatness:	+/- 1 dB into 50 Ω
Input Power for Rated Pout:	0 dBm (1 mW)
Input Impedance / VSWR:	50 Ω / 1.5:1 maximum
Output Impedance / VSWR:	50 Ω / 1.1:1 maximum
Harmonic Level:	All harmonics better than -35dBc at full power.
Ruggedness:	∞:1 VSWR
Stability:	Unconditional into any passive or reactive load
Protection:	Unit will withstand input signal of +30 dBm without damage.
AC Input:	84 – 240 VAC
Temperature Range:	0° – 45° C
Cooling:	Forced Air (front to back)
Dimensions (H x W x D):	3.5 x 19 x 22.5 inches 88.9 x 482.6 x 571.5 mm
Weight:	30 lbs / 14 Kg
Connectors:	N (sample Ports BNC)
Rack Mounting:	Optional
RF Input Signal:	AM, FM, SSB, Pulsed

Table 1: Specification of E&I 500S06 RF power amplifier

3 Measurements

3.1 General Setup

All tests were performed with the following test signal provided from the WSV R-Mode/DGNSS-Modulator providing MSK-Signal for DGNSS correction data within the radio beacon band 283.5-325 kHz at a data rate of 100 bit/s and two CW-signals at frequencies +/- 225 Hz offset to the MSK centre frequency, as shown in figure 1.

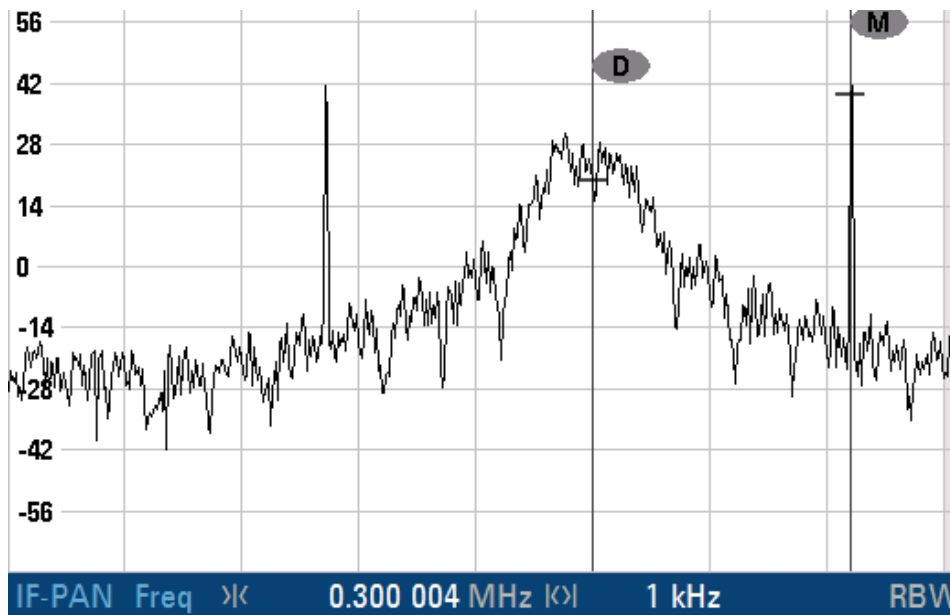

Figure 1: Power spectrum of the R-Mode/DGNSS modulator output signal

3.2 Lab Measurements

3.2.1 Setup

Figure 2 shows the general measurement setup for the test at the Koblenz FVT-Lab.

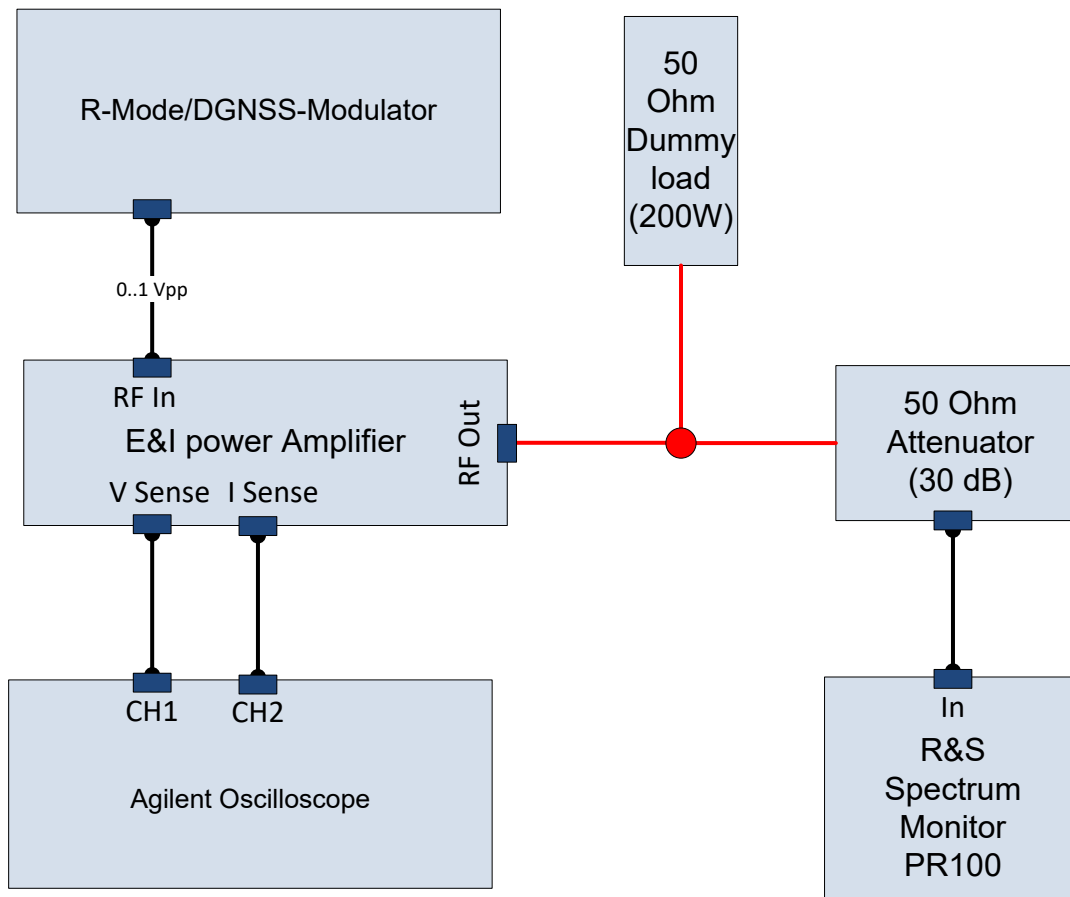

Figure 2 Setup for the Koblenz lab test

3.2.2 Measurements

Date: 19.05.2020

Location: FVT-Lab, Koblenz (Germany)

Description of test:

The E&I amplifier was connected to an R-Mode/DGNSS modulator providing the test signal (Figure 1) to the input of the E&I power amplifier. The power level of the E&I amplifier was monitored on an oscilloscope using the V- and I- sense outputs of the amplifier. With an input signal of approximately 0.15Vpp a power level of 100 Watt was assumed.

The output was given to a 50 Ohm dummy load with a T-connector. The other site was connected via a 30 dB attenuator to the spectrum measurement device (R&S PR 100).

Results:

- A clear spectrum at the spectrum monitor PR100 was observed.
- No intermodulation was detected

Remarks:

After increasing the input level towards roughly 0.3Vpp the attenuator was damaged. Thus no further test could be performed.

Conclusion:

- The E&I amplifier could be used to provide a combined R-Mode/DGNSS-signal without intermodulation
- No documentation was possible due to the damaged attenuator.
- No further tests could be performed in the lab

3.3 Measurements at R-Mode/DGNSS site in Zeven

3.3.1 Setup

Figure 3 shows the general measurement setup for the test at the operational Zeven R-Mode/DGNSS site. Figure 4 shows a picture of the test setup at Zeven R-Mode/DGNSS site.

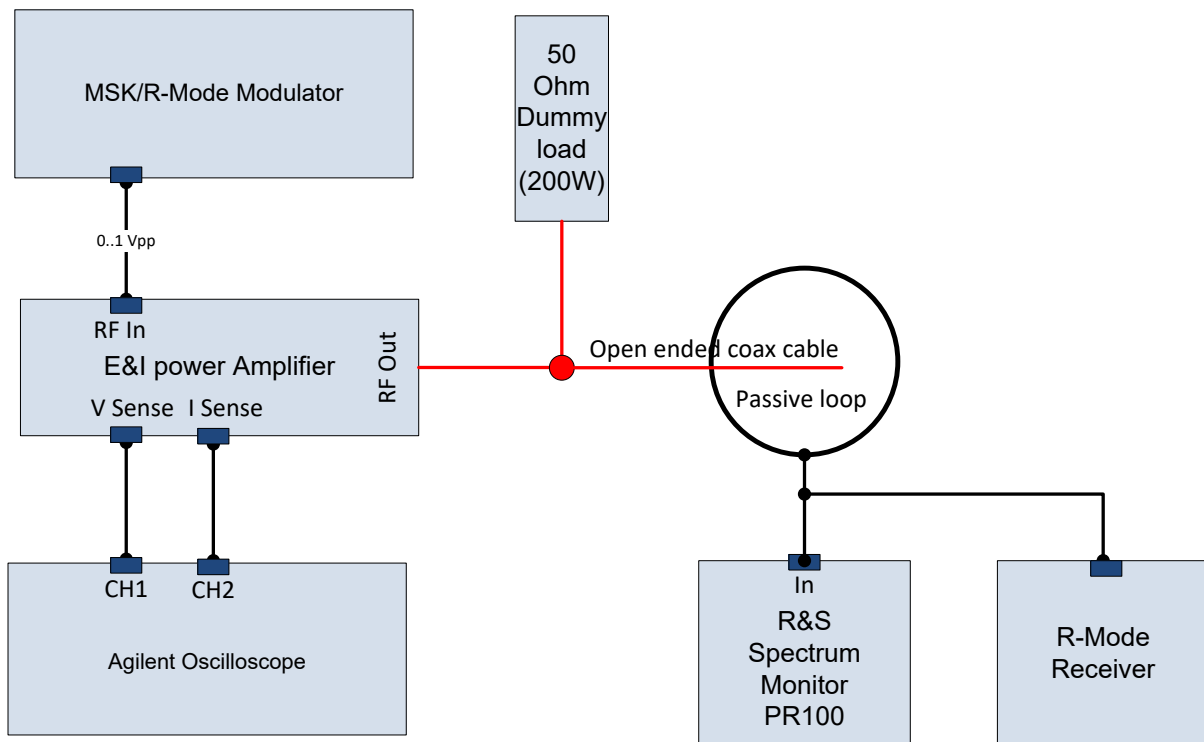

Figure 3 Setup for the Zeven test



Figure 4 Picture of the setup for the Zeven test

3.3.2 Measurements

Date: 23.06.2020

Location: Zeven R-mode/DGNSS site (North Germany)

Description of test 1:

The E&I amplifier was connected to the operational Zeven R-Mode/DGNSS modulator providing the test signal at 303.5 kHz/100 bit/s to the input of the E&I power amplifier. The power level of the E&I amplifier was monitored on an oscilloscope using the V- and I- sense outputs of the amplifier. With an input signal of approximately 0.2V_{pp} a power level of 100 Watt was assumed (see Figure 5).



Figure 5: R-Mode/MSK modulator

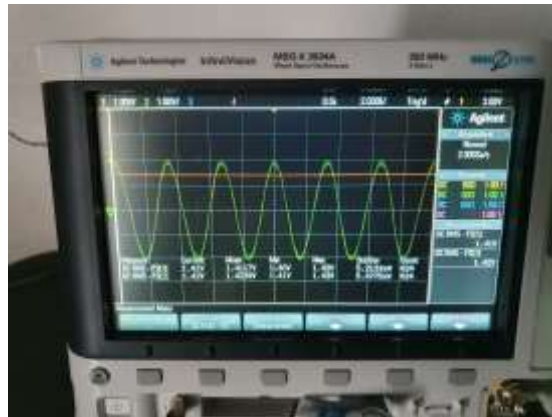

Oscilloscope for power monitoring

The output was given to a 50 Ohm dummy load with a T-connector. The other site was connected to an open ended coax cable and a passive loop antenna at the input of the spectrum measurement device (R&S, PR 100).

Results:

- The measurements showed a clear spectrum at the spectrum monitor PR100.
- No intermodulation were detected
- The spectrum is shown in figure 6 for a bandwidth of 1kHz and 50 kHz

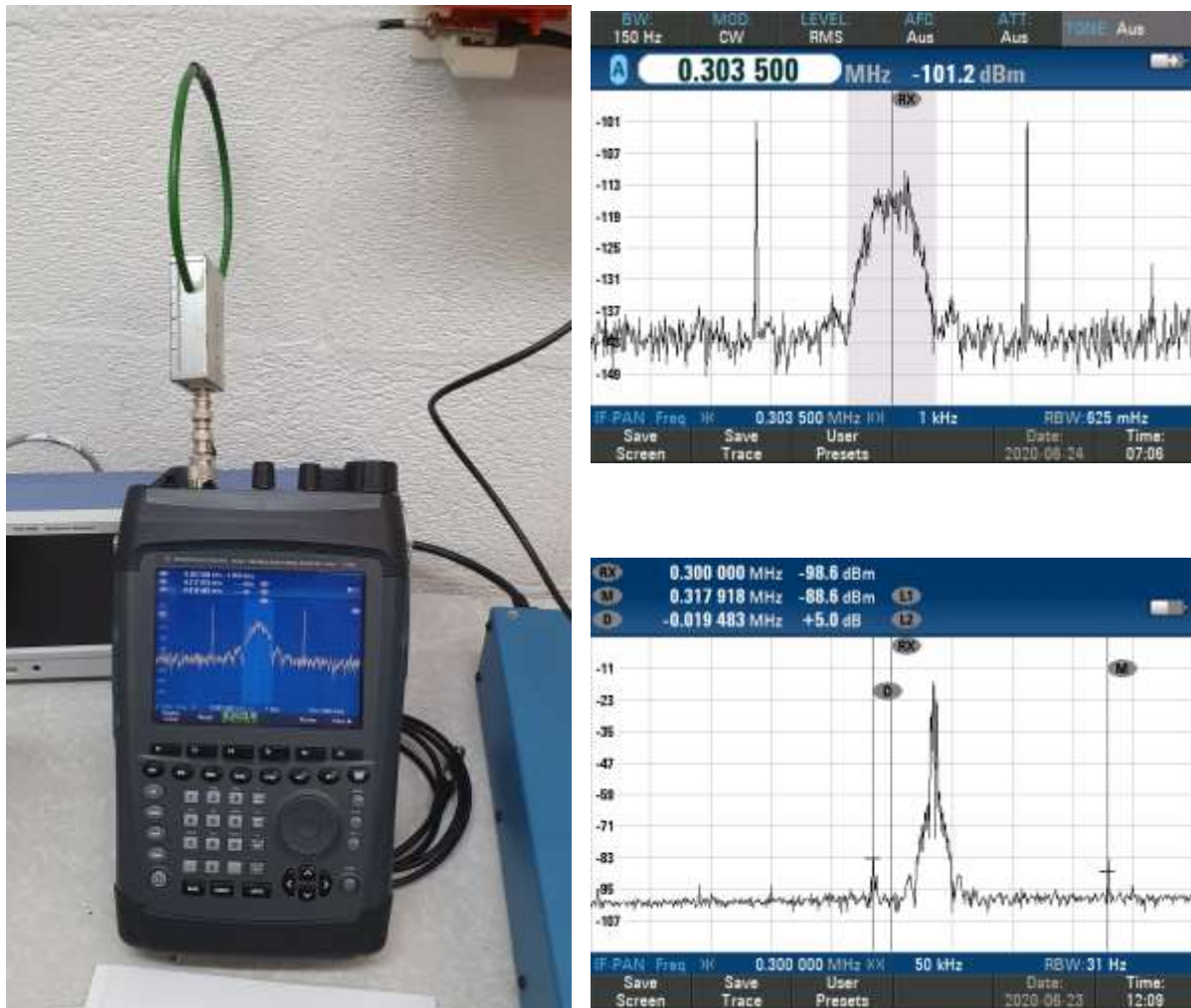

Figure 6 Power spectrum recorded on the PR 100

Left: R&S PR 100 spectrum monitor with passive loop antenna

Right above: MSK and CW-Signals with a bandwidth of 1 kHz

Right bottom: MSK and CW signals with a bandwidth of 50 kHz

Description of test 2:

To test if the generated output-signal from the E&I amplifier could be used to solve for the R-mode CW phase (for range determination) an R-Mode receiver from the German Aerospace Centre (DLR) was connected instead of the PR 100.

Results:

- The signal in the receiver (see power spectrum figure 7) can be used. The signal was very low level due to passive coupling
- The phase on CW1 and CW2 (see figure 8) could be determined. The standard deviation was calculated to 26.5 m (CW1) and 50.6 m (CW2).
- The results are affected by the very low SNR measured at the input of the receiver due to the inefficient coupling of the test signal.
- No interference in- and out band were visible

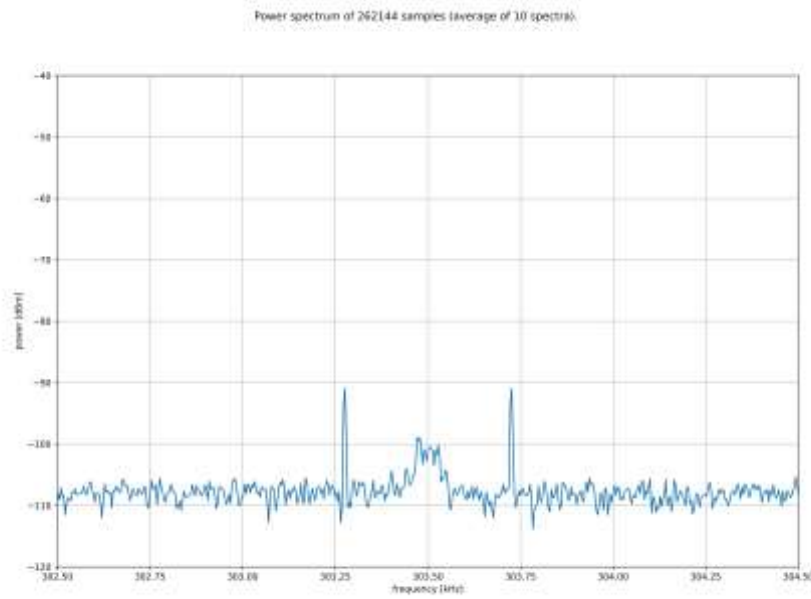

Figure 7: Power spectrum measured with the DLR R-Mode receiver

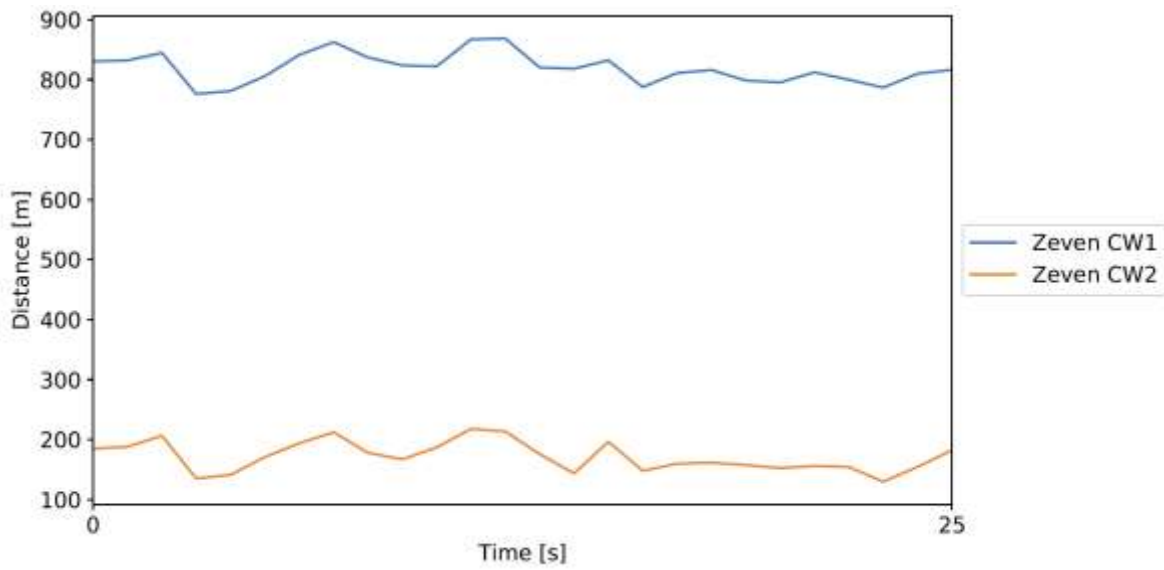

Figure 8: Phase measurement CW1, CW2 with the DLR R-Mode receiver

Conclusions:

- The measurements demonstrate that the R-Mode signal, provided with the E&I power amplifier, can be used on an R-Mode receiver from DLR.

3.4 Measurements at R-Mode/DGNSS site in Koblenz

3.4.1 Setup

Figure 9 shows the general measurement setup for the test at the operational Koblenz DGNSS site. Figure 10 shows a picture of a typical R-Mode/DGNSS system racks as used at German sites.

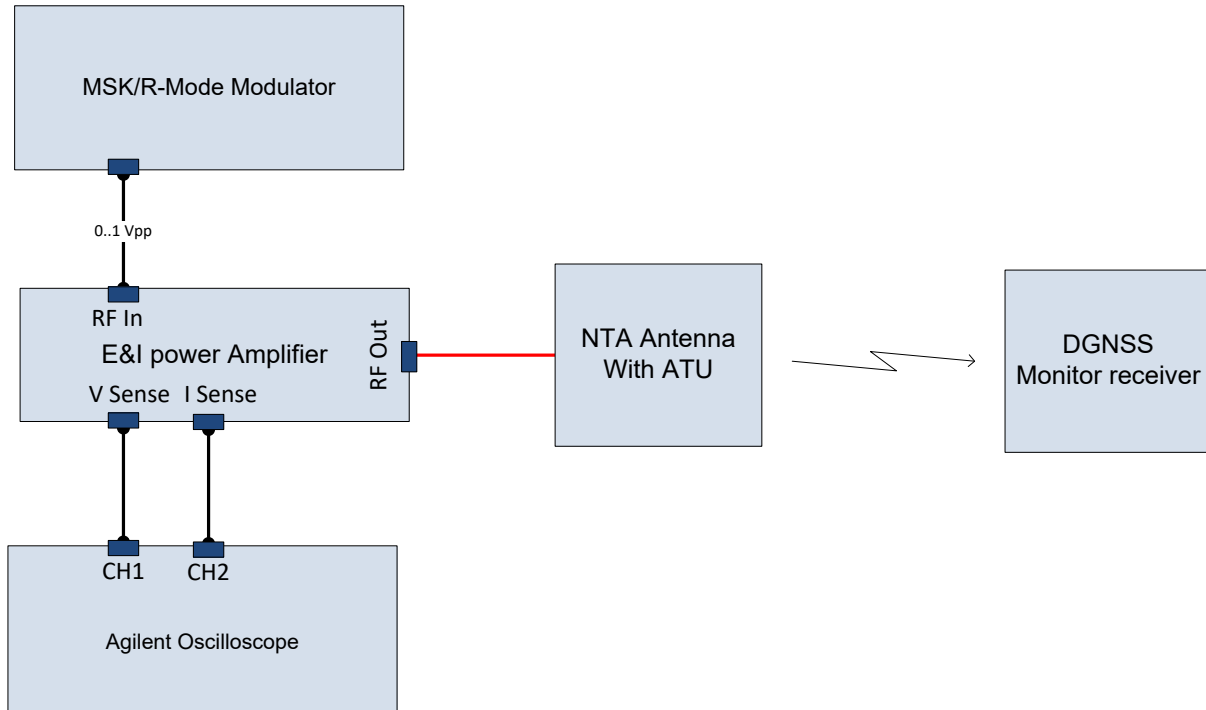

Figure 9 Setup for the Koblenz DGNSS test



Figure 10 Typical R-Mode/DGNSS site in Germany

Left: Amplidan 200W MF transmitter class A/B

Right: System rack with modulator clock and VRS based DGNSS equipment

3.4.2 Measurements

Date: 29.06.2020

Location: Koblenz DGNSS site (North Germany)

Description of test:

The E&I amplifier was used at the operational DGNSS site in Koblenz. This DGNSS station is equipped with an equal R-Mode/DGNSS modulator as used in the FVT-Lab and for the measurement campaign in Zeven.

The main tasks for this measurement are:

- Use of the E&I power amplifier on an operational MF antenna
- Identification if DGNSS user might be affected when the R-Mode/DGNSS signal is transmitted using the new amplifier. This was measured by the observation of a fixed monitor site in a distance of roughly 100 km.

The onsite R-Mode/DGNSS modulator provided the input signal to the E&I power amplifier with at a frequency of 302.5 kHz/100 bit/s with a level of roughly 0.2Vpp. The power level of the E&I amplifier was monitored on an oscilloscope using the V- and I- sense outputs of the amplifier.

The output of the power amplifier was given directly to the MF antenna feeding cable. The power level was increased until the field strength level provided to the far filed monitor showed the same level as normally used with the onsite Amplidan transmitter.

To evaluate any effects for DGNSS users the monitor site was observed for roughly an hour with respect to:

- Field strength level
- SNR
- Word Error Rate
- DGNSS-Modus



Figure 11 Typical MF antenna used on German R-Mode/DGNSS sites (Typ NTA, Koblenz DGNS)

Results:

- The spectrum was measured and provided a clear signal without in- or out band interference (Figure 12)
- The E&I power amplifier can be used at the NTA-Antenna used in Koblenz (Figure 11)
- The far filed monitor site provided stable behaviour with respect to the analysed parameter.
- The word error rate showed no change with respect to the R-Mode signal transmission from the E&I power amplifier

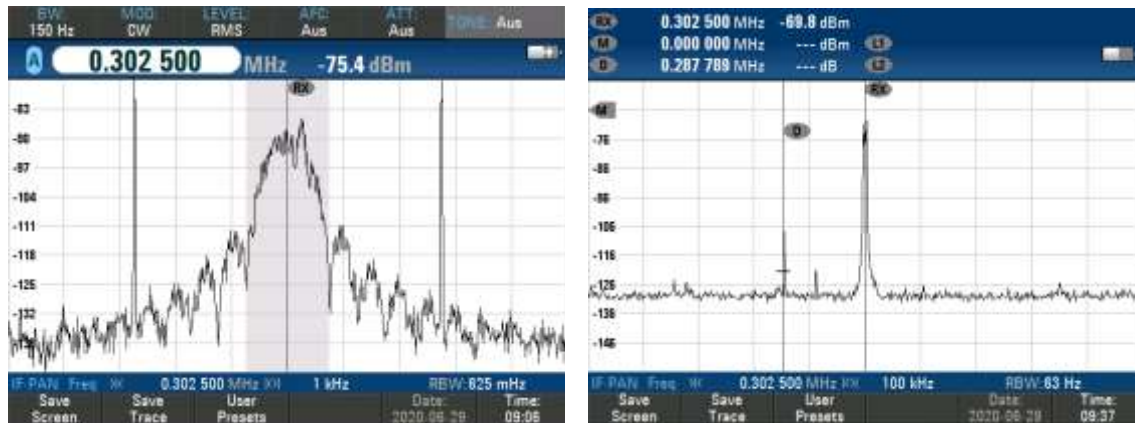

Figure 12 Power spectrum recorded on the PR 100

Left: MSK and CW-Signals with a bandwidth of 1 kHz

Right: MSK and CW signals with a bandwidth of 100 kHz

Conclusions:

Based on the performed measurements the E&I power amplifier can be used as a transmitter to provide R-Mode/DGNSS transmissions in the radio beacon band (283.5-325 kHz) without any intermodulation or in- and out-band interference. The measurements at Koblenz DGNSS site showed also that legacy DGNSS users are not affected by transmissions with a combined R-Mode/DGNSS signal transmitted via the E&I power amplifier, Typ 1000S04.

4 References

- [1] P. F. S. G.W. Johnson, „Part I “Feasibility Study of R-Mode using MF DGPS Transmissions”,“ January 2014.
- [2] P. S. G.W. Johnson, „Part II, "Feasibility Study of R-Mode using MF DGPS Transmissions”,“ March 2014.
- [3] ITU, „Recommendation M.823-3, Technical characteristics of differential transmissions for global navigation satellite systems from maritime radio beacons in the frequency band 283.5-315 kHz in Region 1 and 285-325 kHz in Regions 2 and 3,“ 2006.