



2



EUROPEAN
REGIONAL
DEVELOPMENT
FUND

EUROPEAN UNION



Time and Frequency Transfer by use of Fiber Optic Cable in R-Mode Baltic 2 Project

Issue: 4.0
Issue Status: Approved
Issue Date: 10/01/2022

	Name	Partner
Provided	Krzysztof Bronk	NIT National Institute of Telecommunication
Review	Carsten Rieck	RISE Research Institutes of Sweden AB
Approval	Stefan Gewies	German Aerospace Center (DLR)

Document Information

Project Title	R-Mode Baltic 2
Work Package No.	WP4 GA 4.1
Document Title	Time and Frequency Transfer by use of Fiber Optic Cable in R-Mode Baltic 2 Project
Description	The document discusses the technical concept of binding a UTC time reference to an R-Mode base station using a Polish optical fibre communication network of the Maritime Office Gdynia
Date	10/01/2022
Lead Author	Marek Dziewicki
Lead Author's Contact Information	National Institute of Telecommunication Wireless Systems and Networks Department Telephone: +48 691 766 172 E-mail: dziewam@poczta.onet.pl
Contributing Author(s)	Krzysztof Bronk, Rafal Niski, Marek Ledóchowski, Adam Lipka
Approval	Yes

Track Changes

Issue	Date	Pages	Change	Author, Company
01	18/10/2021	24	general	Marek Dziewicki
02	21/10/2021	31	Executive Summary	Marek Dziewicki, Adam Lipka
03	22/10/2021	30	NIT approval	Krzysztof Bronk
03CR	09/12/2021	29	RISE remarks and corrections	Carsten Rieck
04	14/12/2021	31	Final version	Marek Dziewicki, Krzysztof Bronk, Adam Lipka

SHORT DESCRIPTION OF PROJECT

The R-Mode Baltic 2 project is co-financed by the European Regional Development Fund within the Interreg Baltic Sea Region Programme.



This report is available for download on the project website <https://www.r-mode-baltic.eu>.

WP 4 Group of activities 4.1 R-Mode system self-synchronisation

Lead: RISE Research Institutes of Sweden AB

NIT is taking the responsibility to conceptually demonstrate how to bind a UTC time reference to an R-Mode base station using a Polish optical fibre communication network of the Maritime Office Gdynia, a project observer, which will support this activity. Together with RISE, the established link will be calibrated and evaluated using GNSS time transfer.

Executive Summary

Problem Statement

The radionavigation project R-Mode Baltic 2 deals with determining the maritime moving object's (ship's) position by radio signals measurement of the distance between the receiver and reference points on the coast. It is a method called trilateration.

As demonstrated in the previous phases of the R-Mode project, timing errors at the transmitter's and receiver's sites represent important components of the position error.

The original solution proposed in the project was that all transmitting stations and receivers were equipped with their own atomic time generators synchronized by the GPS satellite system. Since this solution is expensive, it was decided that it might be cheaper to establish one central time standard of high accuracy and to transfer the reference frequency and time from that standard to the coastal stations (transmitters).

The task posed in GA 4.1 is to propose a method of time and frequency distribution /synchronization and conceptually demonstrate how to bind a UTC time reference to an R-Mode base station using a dedicated optical fiber communication network of the Maritime Office in Gdynia (MOG). The report lists several methods and techniques applied to compensate the delay of transfer via fiber optic transmission lines, however, only two of them are able to satisfy the requirements of time transfer.

These techniques are called White Rabbit and ELSTAB.

In order to investigate the topic from the theoretical and practical side, contacts were established with the owner and operator of the fiber optic network that connects marine coastal stations, i.e. the Maritime Office in Gdynia, as well as with scientific and research institutions in Poland:

- CBK (Space Research Center in Poznań),
- AGH (AGH University of Science and Technology in Kraków) and
- PSNC (Poznań Supercomputing and Networking Center).

Static R-Mode VDES radio link tests

The report describes propagation tests of the static VDES radio link installed across the Gulf of Gdansk which were carried out by the National Institute of Telecommunications (NIT) in the R-Mode project. The main goal was the analysis of the propagation impact of the maritime VHF radio channel on the ranging accuracy when using time-based correlation methods.

It was proposed to replace the rubidium generator at the receiver side in Jastarnia by using the fiber optic cable to transfer time and frequency from the atomic reference generator in Gdynia, mounted at the transmitter side. Comparing these tests with the results obtained for synchronization via a fiber optic line would help to ensure a greater separation from additional sources of timing error – thus greatly enhancing the scientific value of the measurements.

Proposed solution

To satisfy the requirements of the R-Mode VDES time and frequency synchronization of the transmitter and receiver radio link installed across the Gulf of Gdansk, it was proposed to use a fiber optic network managed by the Maritime Office in Gdynia and the technology called ELSTAB to transfer frequency and time.

The ELSTAB technique and technology developed by the AGH University of Science and Technology in Kraków was selected on the following grounds:

- The results of the thorough review of various F/T transfer techniques, their recognition and the availability of the necessary equipment, as well as professional assistance.
- The inventors of this method declare their willingness to participate in tests of the fiber-optic network between Gdynia and Jastarnia and will also provide and install the appropriate equipment.
- The MOG declares its readiness to carry out the technical adaptation of the existing transmission path and the measurements of its transmission parameters. It is possible to perform joint calibration and then carry out the time and frequency accuracy transfer tests on the Gdynia - Jastarnia section.

List of Figures

Fig. 3.1 The Quartzlock E80-GPS rubidium oscillator used at the R-Mode VDES station in the port of Gdynia.....	12
Fig. 3.2 Rubidium generator type LL-3760 synchronized with GPS, used at MF DGPS R-Mode reference stations.....	12
Fig. 3.3 Reference generator mounted in the rack at DGPS R-Mode Rozewie station, 2021..	13
Fig. 5.1 Two-way time measurement - PTP block diagram	17
Fig. 5.2 The general idea of ELSTAB – to compensate phase and delay.....	18
Fig. 5.3 ELSTAB block diagram introducing the frequency transfer method [9].....	19
Fig. 5.4 Phase noise in relation to offset frequency for the time constant=100 s [8].	19
Fig. 5.5 ELSTAB technology – equipment to be installed for fiber optic T/F dissemination [4].	20
Fig. 6.1 The chart of the Gulf of Gdansk, distance between Gdynia and Jastarnia marked in red.....	21
Fig. 6.2 VDES test-bed transmitter block diagram (Gdynia Port).	22
Fig. 6.3 Rack-mounted VDES R-Mode transmitter hardware and the 20m tower in the port of Gdynia.....	23
Fig. 6.4 R-Mode VDES receiver block diagram (Port of Gdynia).....	23
Fig. 6.5 Installation of R-Mode VDES receiver hardware in the port of Jastarnia	25
Fig. 6.6 Block diagram of the MOG’s fiber optic path between Gdynia and Jastarnia via Hel..	27
Fig. 6.7 Block diagram of the equipment for F/T transfer from Gdynia to Jastarnia using fiber optic cable.....	28

List of Tables

Tab. 3.1 Types and stability of frequency generators used in telecommunication and radionavigation.....	11
---	----

Abbreviations

CERN	<i>Conseil Européen pour la Recherche Nucléaire (European Council for Nuclear Research)</i>
ELSTAB	<i>Electronic Stabilisation – technique based on active compensation of fiber delay fluctuations</i>
GNSS	<i>Global Navigation Satellite System</i>
GPS	<i>Global Positioning System</i>
MF	<i>Medium Frequency</i>
PNT	<i>Position, Navigation and Time</i>
R-Mode	<i>Ranging Mode</i>
TOA	<i>Time Of Arrival</i>
VDES	<i>VHF Data Exchange System</i>
VHF	<i>Very High Frequency</i>

CONTENTS

List of Figures.....	6
List of Tables	6
Abbreviations	7
CONTENTS	8
1 Introduction	9
2 European time transfer projects	10
3 R-Mode project requirements for time and frequency transfer accuracy	11
3.1 Reference parameters in the R-Mode documents	11
3.2 Available sources of time and frequency	11
4 Protocols and techniques applied for fiber optic transfer lines.....	14
4.1 Computer Network Protocols(NTP).....	14
4.2 Precision Time Transfer (PTP)	14
4.3 White Rabbit technique	14
4.4 ELSTAB technique	15
5 Transmission line delay reduction methods	16
5.1 Features of fiber optic lines	16
5.2 Methods of delay measurement and reduction.....	16
5.2.1 Two-way time transfer.....	16
5.3 ELSTAB solution	17
5.4 ELSTAB technology	20
6 Concept of using the selected F&T transfer technique in the R-Mode Baltic 2 static measurements	21
6.1 VDES measurements across Gdansk Bay	21
6.2 Technical solutions proposed for the MOG network	25
6.2.1 Course of organizational and technical arrangements	25
6.2.2 Scheme of the Gdynia - Jastarnia fiber optic network	26
6.2.3 Description of VDES+ELSTAB test hardware configuration	28
7 Conclusions.....	30
8 References.....	31

1 Introduction

One of the main tasks of the R-Mode Baltic 2 project was to determine how to transfer and synchronize time and reference frequencies via fiber optic cables connecting the transmitting (shore) base stations with a common central reference time source. This could be performed in order to lower the costs and to simplify the design by reducing the number of atomic clocks required in the system. It is essential for marine systems that a fiber optic cable is available between the headquarters central reference time source and the reference shore stations.

The following study mainly uses the term “time transfer”, but the term “time distribution” can also be found here. Both terms should be considered as equivalent.

The R-Mode marine navigation system operates by measuring the distance (range) between a mobile receiver and reference points (transmitters) located on the shore. For this purpose, in the ship's navigation receiver, the phase measurement of radio signals sent by the coastal station transmitters operating in the MF band is essential. In case of the VHF band and VDES receiver, the autocorrelation of pseudo-random codes is used as part of the VDES system messages. The R-Mode signals generated in the transmitting stations of the MF and VHF band must be in-phase (coherent), and the time stamps of transmission and reception must be determined with very high accuracy, preferably synchronized by a common time source. Due to the TOA method, the accuracy of the ship's position determination is influenced by the accuracy of the time synchronization of the transmitting station's clocks. The R-Mode requirements are demanding and imply the use of atomic frequency standards, which is a technically complex and costly solution. This significantly increases the overall costs of a system based on the operation of numerous transmitting shore stations equipped with such generators, as well as receivers.

There are various methods of time transfer in telecommunications, but the most common is satellite transmission using GNSS systems (GPS, Galileo, Glonass, Beidou). This is what the R-Mode system is designed to avoid, though, as its purpose is to serve as a back-up system in the event of the GNSS outage or significant interference of satellite signals. In terrestrial telecommunication systems, optical fibers are also used for time and frequency transfer, which is the main topic of this study.

During the preliminary problem analysis, it was found that the issue of time distribution is actually dealt with by many research institutions and there are numerous research projects dedicated to that topic.

In order to investigate the topic from the theoretical and practical side, contacts were established with the owner and operator of the fiber optic network that connects marine coastal stations, i.e. the Maritime Office in Gdynia, as well as with scientific and research institutions in Poland: CBK (Space Research Center in Poznań), AGH (AGH University of Science and Technology in Kraków) and PSNC (Poznań Supercomputing and Networking Center). Information exchange was also continued with the project partner - the Swedish research institute RISE, which deals with time metrology professionally.

2 European time transfer projects

The problem of time transfer over long distances without losing significant accuracy of its determination has been and remains the subject of many analyzes and has been utilised in many practical solutions on a European and global scale.

Due to the goal of using the fiber-optic line, we identified several important EU projects that were dedicated to time and frequency transfer methods via fiber-optic network:

- CERN 2006 - White Rabbit Project (PTP Standard IEEE 1588 in 2008), [7, 10]
- CLONETS – CLOck NETwork Services Strategy and innovation for clock services over optical-fiber networks (H2020), [9]
- OFTEN: Optical frequency transfer - a European network, 2019, https://www.ptb.de/emrp/often_home.html
- TiFOON - Time and Frequency Dissemination over Optical Fiber Networks, EMPIR 2021, <http://empir.npl.co.uk/tifoon/>
- WRITE –Precision Time for Industry, EMPIR 2018-2021 <http://empir.npl.co.uk/write/>

3 R-Mode project requirements for time and frequency transfer accuracy

During the initial phase of the R-Mode project, the basic assumptions were made with respect to the error components of the geographical position determined on the basis of range measurements. It was assumed that the R-Mode system should determine the 2D (X, Y) position of the ship with an error of less than 10 m. This corresponds to a timing error in the order of 30 ns.

3.1 Reference parameters in the R-Mode documents

The WP3.1 "Base Line and Priorities" fundamental document specifies the time transfer accuracy requirements of 10 ns error relative to UTC [0]. For the purposes of the concept of time transfer through the fiber optic channel, the 10-times more accurate requirement – i.e. 1 ns – was adopted.

Following the consultations with AGH, PSNC and publications on the subject, it was determined that the optical fiber technology and the proposed ELSTAB transfer technique should meet these requirements. Therefore, this study focuses on this particular technology [8, 9].

3.2 Available sources of time and frequency

Taking into account the requirements formulated in the R-Mode Baltic Project, as well as the economic and technical constraints, atomic time generators based on the rubidium standard were selected for use in transmitting shore stations. This is due to their long-term stability and low phase noise values. The table below indicates the typical parameters of various frequency generators [1], [2], [3], and [12].

Tab. 3.1 Types and stability of frequency generators used in telecommunication and radionavigation

No	Name/ type	Accuracy	Short term stability $\Delta F/F$ [1s]	Long term stability>24h
1.	TCXO- OCXO	1E-6 to 1E-8	1E-7	1E-7
2.	Atomic rubidium RbO	1E-10	2E-12 do 3E-13/s	1E-12
3.	Atomic cesium CS	1E-13 to 5E-14	1E-12 do 1E-14/s	1E-13
4.	Hydrogen Maser HM	1E-12	8E-14 do 1,5E-15/s	1E-15

Cesium or hydrogen standards have the best long-term frequency stability, but these are costly solutions and their technical implementation may also be problematic: especially due to large dimensions, high power consumption and operational environmental requirements.

In this concept, the generator is expected to have 2 frequency outputs of 10 MHz and time pulses of 1 PPS.

The projects of the National Institute of Telecommunications (NIT) used a rubidium generator of the E80-GPS type, synchronized by the GPS satellite time signal [11].



Fig. 3.1 The Quartzlock E80-GPS rubidium oscillator used at the R-Mode VDES station in the port of Gdynia

GPS Timing Receiver



LL-3760
GPS Timing Receiver Front View

Fig. 3.2 Rubidium generator type LL-3760 synchronized with GPS, used at MF DGPS R-Mode reference stations.



Fig. 3.3 Reference generator mounted in the rack at DGPS R-Mode Rozewie station, 2021.

4 Protocols and techniques applied for fiber optic transfer lines

Techniques and technologies appropriate for time and frequency transfer were gradually improved by new protocols' introduction. Terrestrial transmission of high precision time synchronization signals involves two key technologies: Network Time Protocol (NTP) and Precision Time Protocol (PTP), to provide compensation technique for transmission delay and phase jitter.

However, the solutions that stabilize the phase of transmitted sinusoidal signal are well suited for high-quality frequency distribution but cannot be extended for precise time distribution.

4.1 Computer Network Protocols (NTP)

The NTP (Network Time Protocol) is very widely used to transfer time information between computer systems linked over a network such as the Internet. The two-way exchange of messages is typically initiated by a client system, and the calculation of the path delay and the time offset is also performed by that system based on the time tags provided by the remote server. A typical routed network path will have a delay of 50 ms to 300 ms, and both the magnitude of the delay and its symmetry can vary significantly from one query to another.

NTP protocol cannot satisfy the R-Mode requirements [5] and [6].

4.2 Precision Time Transfer (PTP)

Precision Time Protocol (PTP - based on the IEEE 1588-2008 standard) was developed in 2008 and is now widely applied to synchronize computer networks [7].

Networks using the Network Time Protocol (NTP) synchronization are only accurate with a precision range below the microsecond, which does not meet the requirements of many systems. Another solution based on a delay request-response mechanism, called IEEE 1588 v2, also known as Precision Time Protocol (PTP), uses synchronization messages to calculate time error between the slave and master clocks. Moreover, by using a hardware-embedded time stamp as well as a Boundary Clock (BC) or Transparent Clock (TC) it is able to compensate the delay and phase jitter incurred by network components or protocol stacks. The IEEE 1588 version 2 achieves time precision of sub-microseconds [7].

The utilization of synchronization protocol to transport high precision time synchronization signals via optical fiber systems is expected to be a leading technology in the future [5].

Theoretically, the PTP protocol could be used as a synchronization method for R-Mode, but available hardware cannot satisfy the R-Mode requirements.

4.3 White Rabbit technique

White Rabbit is the name of a collaborative project including CERN, GSI Helmholtz Centre for Heavy Ion Research and other partners from universities.

The White Rabbit Network is based on the existing IEEE standards, while maintaining backward-compatibility to meet CERN's requirement (if needed). Technically, the White Rabbit combines Synchronous Ethernet (SyncE) and PTP (IEEE1588) that uses Ethernet ([IEEE 802.3](#)) to interconnect switches and nodes, and the Precision Time Protocol ([PTP, IEEE 1588-2008](#)) to synchronize them.

The **main features** of the White Rabbit Network are:

- sub-nanosecond accuracy and picoseconds precision of synchronization,
- capability to connect thousands of nodes,
- typical distances of 10 km between network elements,
- gigabit rate of data transfer,
- fully open hardware, firmware and software,
- commercial availability from many vendors.

High accuracy of synchronization in White Rabbit is achieved by extending the Precision Time Protocol ([PTP, IEEE 1588-2008](#)) [7].

This protocol and associated technology can satisfy requirements of R-Mode system.

4.4 ELSTAB technique

The method and technology of ELSTAB is based on the solution developed by the AGH University of Science and Technology (Krakow) and the PSNC Poznan Supercomputing and Networking Center (Poznan).

The core invention of the ELSTAB solution is to use a pair of electronic delay lines for parallel (separate for forward and backward directions) compensation of the delay fluctuations occurring in the fiber optic transmitting line. As it appears, it is also the main hardware challenge and important element substantially affecting the overall performance of the practical implementation of the ELSTAB system.

Fiber-optic based on ELSTAB T&F transfer offers the possibility to distribute the signals from an atomic source to some distant location with much higher stability than using other techniques.

It also offers the unique capability of determining the propagation delay of the link with the accuracy in the range of picoseconds [8].

Example:

Calibration of the optical link up to 420 km was performed during the practical tests in Poland. On the basis of local measurements at the probability level of 95%, the time accuracy of 0,25 ns was obtained.

This method and associated technology can satisfy the requirements of the R-Mode system.

ELSTAB will also be described in detail in chapter 5.3.

5 Transmission line delay reduction methods

This chapter presents the methods applied to limit and stabilize the delay of transfer via fiber optic transmission lines. Information contained below are based on articles and documents recommended by the AGH and PSNC.

5.1 Features of fiber optic lines

The optical fiber optic line – like any transmission medium – exhibits some fluctuations of the propagation delay, caused by environmental factors. The transfer system must be designed in a way to suppress these fluctuations. Changes of the chromatic dispersion and the knowledge of their properties (i.e., amplitude, noise, time behavior, etc.) are required to understand the resulting fundamental limitations of the stability of the transfer. This is the impact of temperature, which affects both the fiber physical length and the refractive index of the silica glass.

5.2 Methods of delay measurement and reduction

Various ideas for reducing the propagation instability are based on redirecting the signal reaching the remote end of the link. Solutions based on optical fibers become the rapidly emerging alternative. They offer not only much better accuracy but also allow some diversification of the method of the transfer that may be important for safety reasons.

Generally, the solutions that stabilize the phase of transmitted sinusoidal signal are well suited for high-quality frequency distribution but cannot be extended for time distribution.

There are several systems stabilizing the group delay of the signal reaching the remote end that can be used for both frequency and timing signals.

5.2.1 Two-way time transfer

Two-way time transfer involves signals travelling both ways between the two clocks or oscillators that are being compared, as shown in the Figure 5.1 below.

A half-duplex channel is a one-way system that is "reflected" to retransmit a signal in the opposite direction.

In this method, the one-way delay between the transmitter and receiver is estimated as one-half of the measured round trip delay. The delay estimate can be sent to the user and applied as a correction factor, or the transmitter can advance the signal so that it arrives at the user's site on time.

A full-duplex system uses one-way signals transmitted simultaneously in both directions. In this case, data must be exchanged in both directions so that the two data sets can be distinguished.

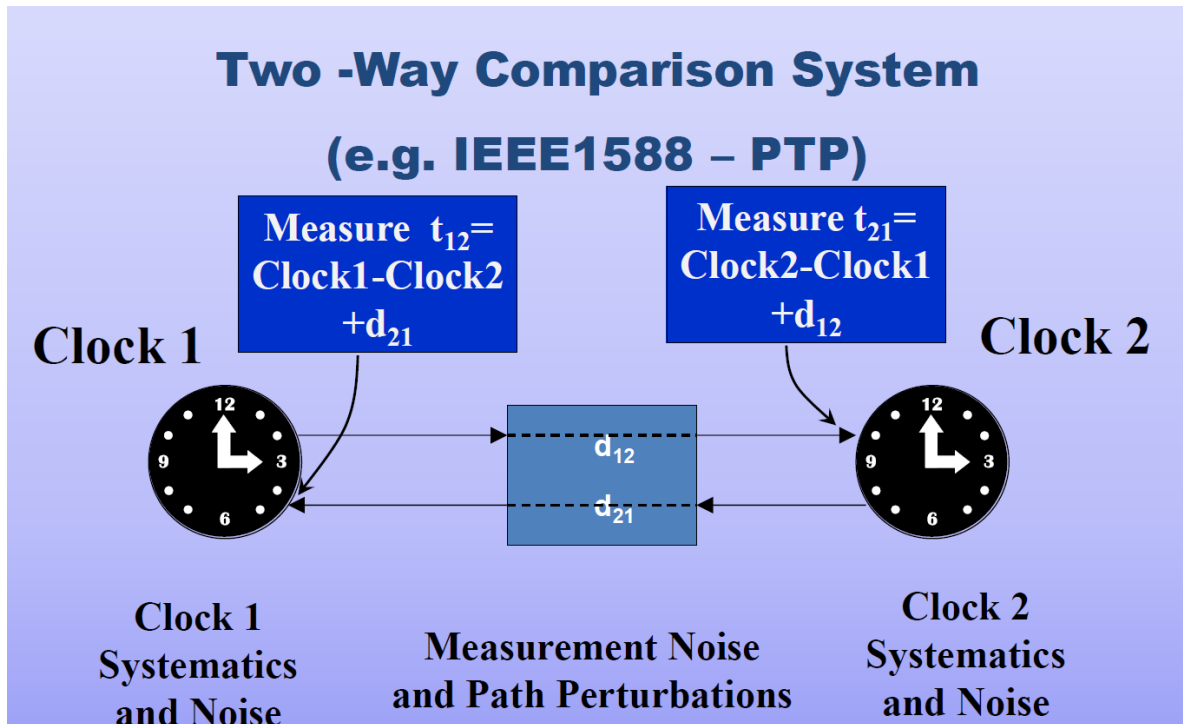

Fig. 5.1 Two-way time measurement - PTP block diagram

Both two-way methods have their advantages and limitations. The half-duplex system has the advantage of only requiring the "reflecting" hardware at one station, but it is susceptible to fluctuations in the delay, especially when the period of the fluctuations is comparable to the round-trip delay.

In full-duplex system, timing information is transmitted in both directions simultaneously. However, it requires the complete transmit and receive hardware at both stations. The system does not depend on the actual length of the path, provided that the inbound and outbound delays are nearly equal. In practice, this requirement may be difficult to fully satisfy, since these systems usually require separate station hardware for two directions (with delays that may not be the same).

5.3 ELSTAB solution

Solutions that stabilize the phase of transmitted sinusoidal signal are well suited for high-quality frequency distribution but cannot be extended for time distribution. On the other hand, systems stabilizing the group delay of the signal reaching the remote end can be used for both frequency and timing signals. The ELSTAB solution, described herein, uses the second approach.

The underlying idea of the electronically stabilized (ELSTAB) solution was to replace the complex and bulky setups used to compensate the delay fluctuations in the optical domain with a pair of electronic variable delay lines placed both in the forward and backward paths of the delay-locked-loop (DLL) structure. The main challenge was that the delay lines should exhibit extremely low phase noise and should be precisely matched in terms of the tuning characteristics [8].

The frequency signal (10 or 100 MHz) propagates through the forward-direction variable delay line, electro-optic (E/O) converter (intensity-modulated laser transmitter) and optical circulator to the optical port of the local module, see Fig. 5.2.

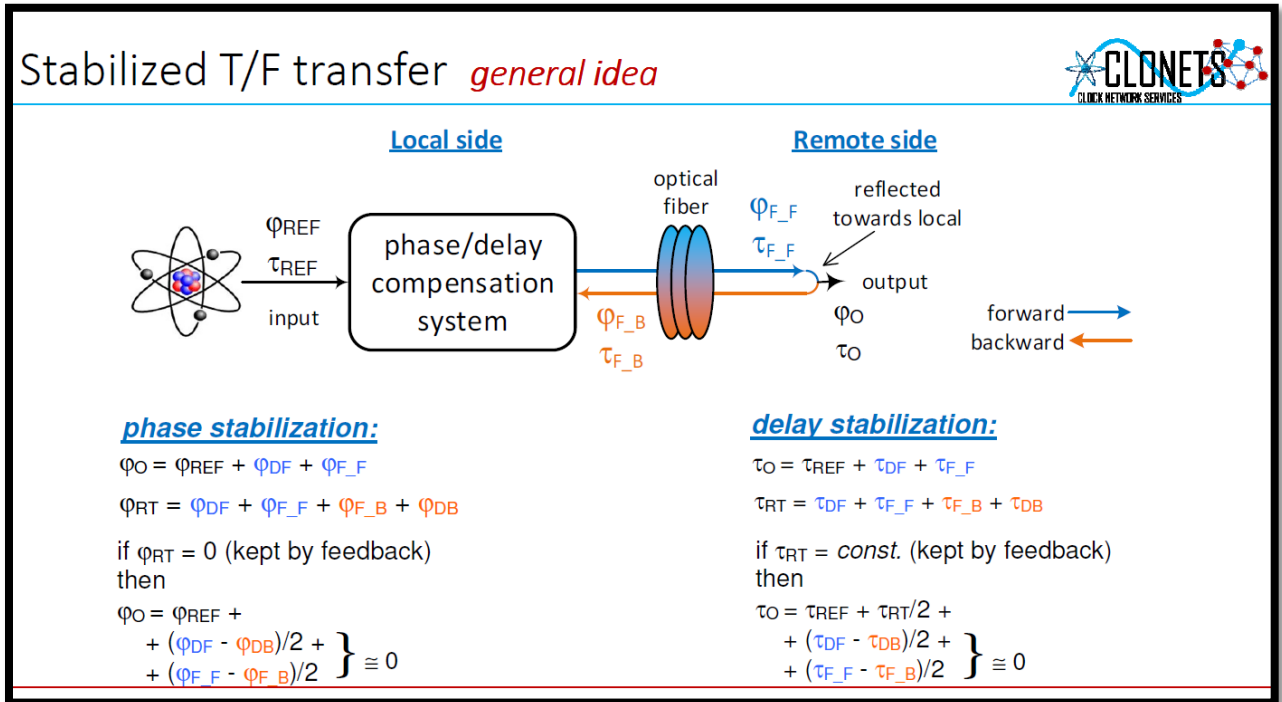

Fig. 5.2 The general idea of ELSTAB – to compensate phase and delay

Next, through the fiber link, the signal reaches the remote module, where it is redirected backward to the fiber and then to the local module. Here, via the backward path (O/E and the second variable delay line), it enters the phase detector. The phase detector senses the phase difference between the input and feedback signals and cancels it by driving the variable delay lines. Thus, the round-trip delay in the DLL system is kept constant, unaffected by the fluctuations of the fiber delay.

The ELSTAB compensation idea for the frequency transfer is presented in Fig. 5.3.

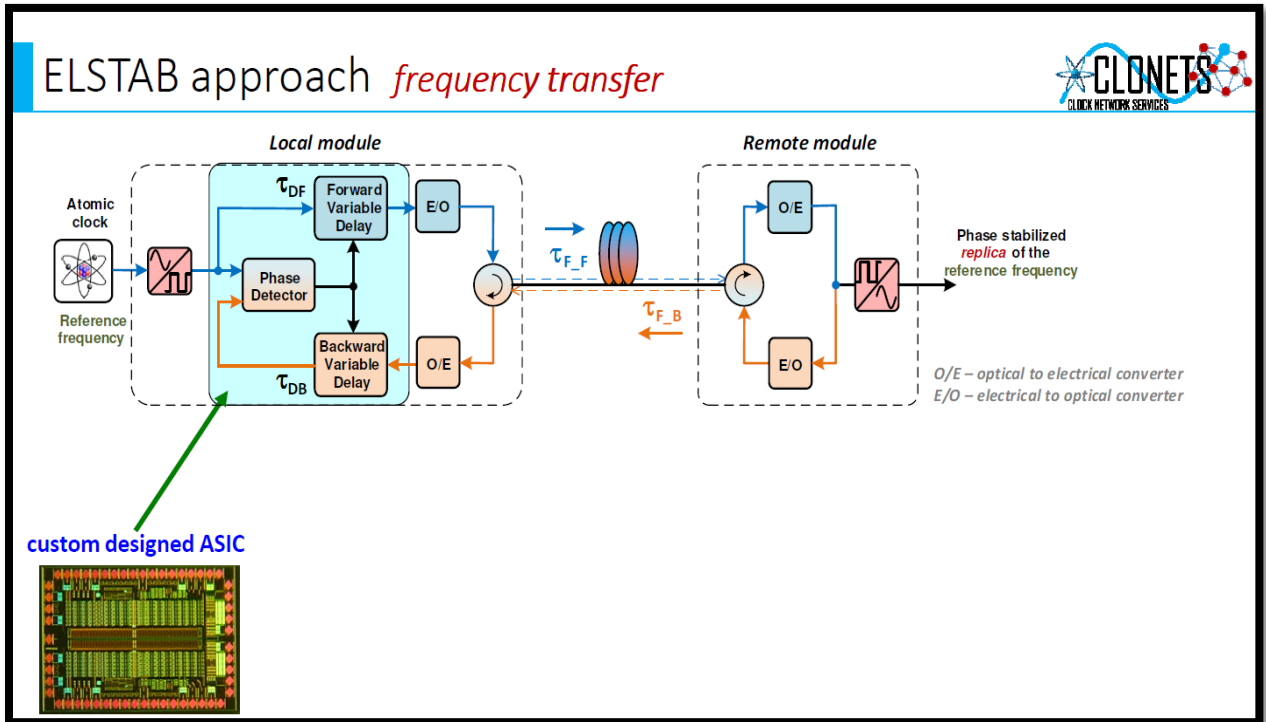

Fig. 5.3 ELSTAB block diagram introducing the frequency transfer method [9]

To implement this method, the custom designed ASIC module was applied.

Using that method, the R-Mode requirements for 1-10 ns of time accuracy transfer as well as frequency of 10 MHz can be easily satisfied for fiber optic lines at the distances of 100 km. Low phase noise of this solution is also critical for the R-Mode method of range measurements.

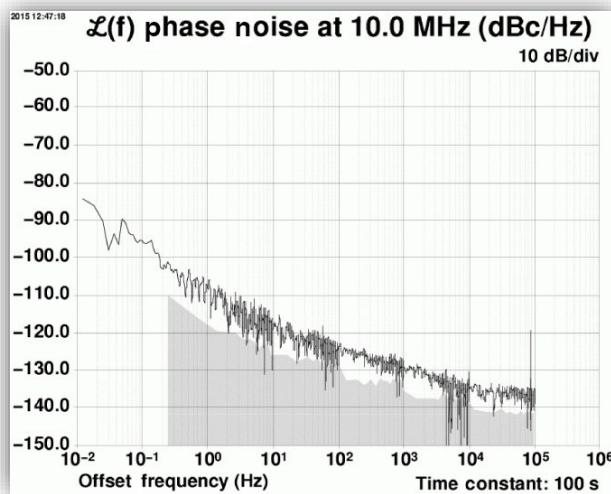

Fig. 5.4 Phase noise in relation to offset frequency for the time constant=100 s [8].

5.4 ELSTAB technology

In fig. 5.5, the equipment designed for fiber optic time and frequency dissemination (5/10/100 MHz + 1/100 PPS) is shown.

Basic features:

- it is based on active compensation of fiber delay fluctuations,
- typically uses dark fiber, but dark channel is also possible,
- compensation range: 100 km (standard) or up to 1000 km (LR version),
- ADEV < 3×10^{-13} for 1 s averaging, < 3×10^{-17} for 105 s averaging,
- TDEV < 2 ps for 10 s averaging, < 1 ps for 105 s averaging.

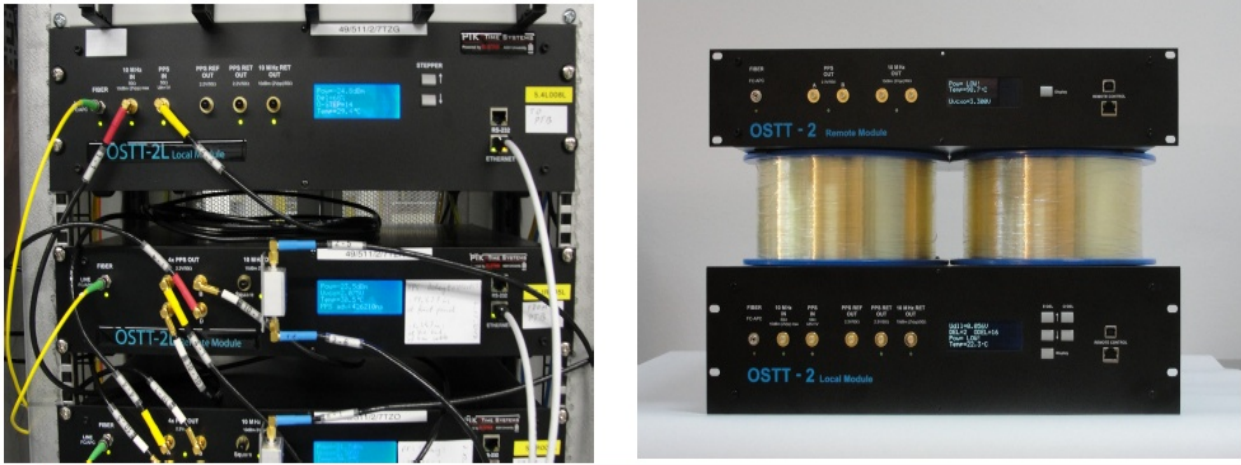

Fig. 5.5 ELSTAB technology – equipment to be installed for fiber optic T/F dissemination [4].

The original setup requires a single fiber working bidirectionally, but there are versions for duplex communication.

6 Concept of using the selected F&T transfer technique in the R-Mode Baltic 2 static measurements

To satisfy the requirements of the R-Mode VDES time and frequency synchronization of the transmitter and receiver radio link installed across the Gulf of Gdansk, it was proposed to use a fiber optic network managed by the Maritime Office in Gdynia and the ELSTAB technology.

6.1 VDES measurements across Gdansk Bay

The main goal was the analysis of the propagation impact of the maritime VHF radio channel on the ranging accuracy when using time-based correlation methods. In order to minimize timing errors, the E80-GPS rubidium GPS disciplined oscillators were installed on both ends of the 20 km radio link [12].



Fig. 6.1 The chart of the Gulf of Gdansk, distance between Gdynia and Jastarnia marked in red

Block diagrams of the VDES transmitter and the VDES receiver are shown in Fig. 6.2 and Fig. 6.3 respectively.

Both testbeds were based on the following hardware components:

- Industrial PC,
- SDR Radio Module (Software Defined Radio), type National Instruments NI USRP2954,
- INPUT filter type PROCOM BPF 2/1-250 (receiver side) or PROCOM BPF 2/2-250 (transmitter side),
- Power Amplifier, POPEK ELEKTRONIK PEA02-2-50 – transmitter side,
- Low Noise input amplifier type WanTcomWLLA0005A – receiver side,
- GNSS reference receiver type U-Blox EVK-M8T,
- VHF omni-directional transmitting antenna with 0 dB gain, mounted at the 20 m msl tower in the Gdynia Port,
- The receiving VHF antenna installed on the roof of the harbour master office in the port of Jastarnia (12m msl).

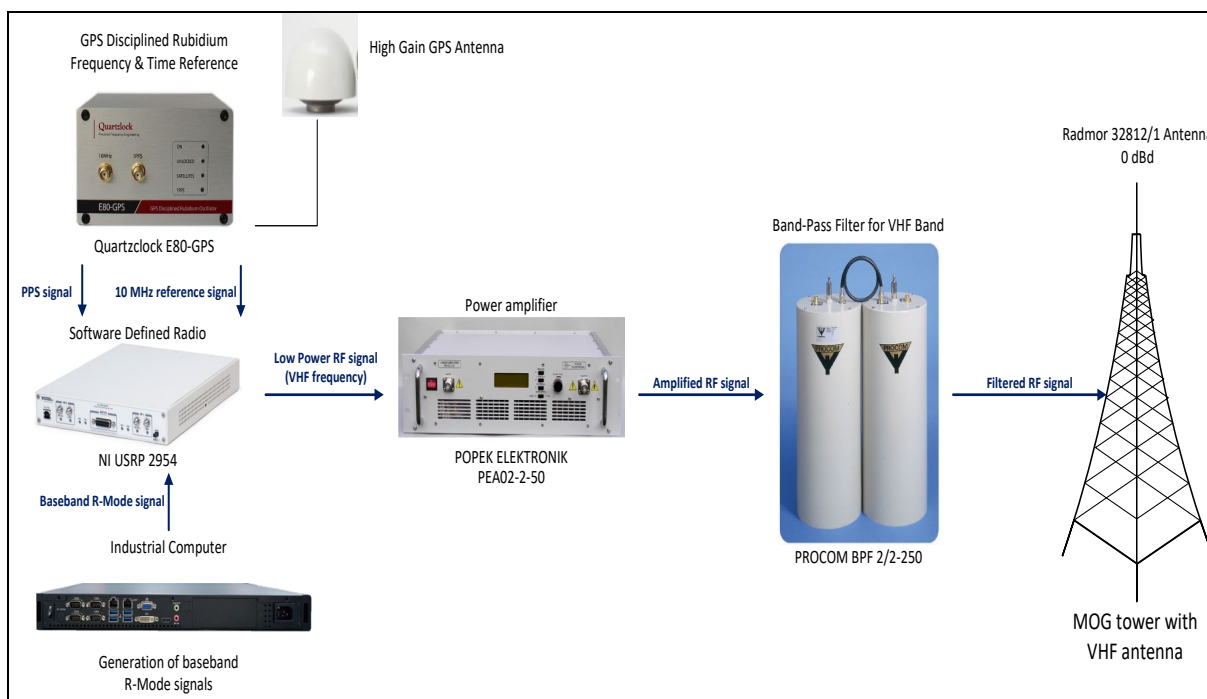

Fig. 6.2 VDES test-bed transmitter block diagram (Gdynia Port).



Fig. 6.3 Rack-mounted VDES R-Mode transmitter hardware and the 20m tower in the port of Gdynia

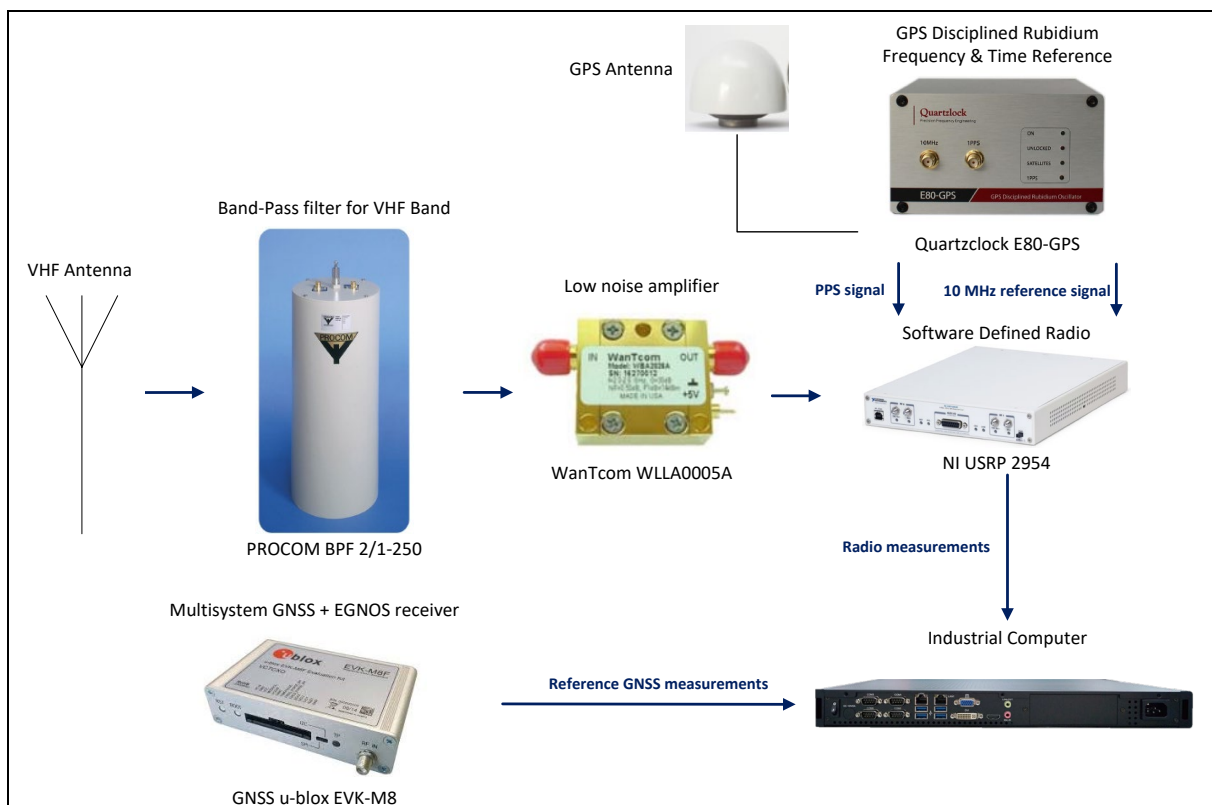

Fig. 6.4 R-Mode VDES receiver block diagram (Port of Gdynia)

Within the frame of the R-Mode research activities, several tests and measurement campaigns have been performed by the NIT. Most of the results have been presented in the project reports [13], [14], including the detailed hardware description of VDES R-Mode Tx/Rx system. Having finalized several test campaigns, the influence of the component selection and optimization process for the transmitter side and the receiver side has been analysed. In particular, this was related to band pass filters, preamplifiers, firmware and hardware of USRP models, etc.

The following analysis after the marine tests has been related to:

- The coverage range of VDES radio link along the sea track Gdynia-Karlskrona versus output power of the radiobroadcast,
- SS – signal strength of broadcast, SNR – Signal to Noise Ratio, power of noise,
- Useful signal strength in relation to BPF filters,
- Ratio of peak correlation and side lobes in relation to useful power strength,
- RMS error curve in relation of LOS measurements, NLOS measurements depending on radio link over Hel Peninsula,
- The new alternating sequence utilization and its comparison with the Gold code-based ranging code,
- The comparison of different types of correlators and reduction of the sampling rate in the receiver.

The goal of this research was to determine the impact of the maritime VHF channel on the VDES R-mode system while minimizing the impact of various sources of additional timing error. This assumption was considered critical in the design and development of the hardware platform. The use of filters, a low-noise amplifier, a disciplined rubidium oscillator, an RTK receiver, GNSS+EGNOS ship reference position determination, and calibration measurements reduced the influence of multiple error sources such as:

- delays at the transmitter and receiver sides,
- errors in determining the station position (RTK receiver),
- errors in determining the reference position of the vessel (GNSS+EGNOS),
- errors caused by noise and interference.

The above studies provide a solid basis for further analysis of:

- a) the propagation effects in the VHF channel versus marine environment changes,
- b) influence on R-Mode signals and
- c) the improvement of position accuracy.

Comparing these tests with the results obtained for synchronization via a fiber optic line would help to ensure a greater separation from additional sources of timing error – thus greatly enhancing the scientific value of the measurements.

Fig. 6.5 shows the locations of the VDES transmitting equipment in the port of Gdynia (UMG laboratory), and the VDES receiver in the Jastarnia harbor master's office. Both of these facilities are located close to the waterline and are connected to the fiber-optic network of the Maritime Office in Gdynia (MOG). On this basis, the idea of using optical fibre to transmit time and frequency from the atomic standard installed in the transmitter in Gdynia was conceived.

This would reduce the cost of the VDES equipment and eliminate time synchronization errors in the receiver.



Fig. 6.5 Installation of R-Mode VDES receiver hardware in the port of Jastarnia

6.2 Technical solutions proposed for the MOG network

The following information was obtained on the basis of technical and organizational agreement with MOG.

6.2.1 Course of organizational and technical arrangements

Based on the exchange of information between the NIT and AGH/PSNC about ELSTAB system capabilities and requirements, it was concluded that Gdynia Maritime Office fiber-optic network has the technical parameters that satisfy the above mentioned ELSTAB requirements. As a result of two-party arrangements and consultation meeting at the Maritime Office in Gdynia, the purpose of the R-Mode Baltic project in terms of time and frequency transfer was presented in detail, indicating the fiber optic network nodes in Gdynia as local, and in Jastarnia as remote. The fiber-optic connection between Gdynia and Jastarnia runs with an underwater cable from Gdynia through Hel, which causes a physical lengthening of the transmission line and the need to compensate time transfer delays. This mainly concerned the link between the VDES transmitter in Gdynia and the VDES receiver in Jastarnia. Perhaps an alternative link could go from Gdynia to DGPS Rozewie station, where the R-Mode broadcasting station is operating in the MF band. Information was exchanged on the necessary technical requirements of the network nodes, taking into account the types of fiber cables, available wires and their occupancy. It concerned in particular, the possibility of working on one wire in two directions. Finally, the Gdynia - Jastarnia link was selected for a detailed technical analysis, with an approximate length of fiber optic connections in both directions of approx. 40 km, with the use of a single dark fiber for transfer in both directions.

6.2.2 Scheme of the Gdynia - Jastarnia fiber optic network

The fiber optic network from Gdynia to Hel was routed across the Gulf of Gdansk on the seabed, and then from Hel along the road to Jastarnia and Rozewie. Hence the necessity of taking into accounts Hel Peninsula shown in the diagram below - Fig. 6.6. The diagram shows the number of splices (seven in total) and the four node points where access to the cable fibers is possible.

As a result of the discussions, the Maritime Office in Gdynia proposed the crossover scheme and estimated optical lengths of individual sections of the Gdynia - Hel – Jastarnia cable route, with a total optical length of 39766 m. A list of patchcords and SFP WDM Ethernet inserts was prepared for the single-wire path.

The necessary time for the MOG IT department to perform such an upgrade has been estimated as 14 days from the date the order is placed. UMG IT Department will perform the ODTR measurement and provide the test results in a two-way relation as well as the as-built documentation containing the parameters of the modified track. The cost of technical modifications (purchase of components and installation work) is estimated at about 5000 PLN.

According to the declaration of the PSNC and AGH group, they can prepare and deliver the necessary amount of T/F transmission equipment needed for the calibration and tests using the ELSTAB system.

The time to assemble, calibrate the path, and perform the measurements was estimated to be 2 to 3 working days.

6.2.3 Description of VDES+ELSTAB test hardware configuration

For the practical implementation of the time transfer tests, it was proposed to set up the transmitting and receiving equipment as shown in the block diagram in Fig. 6.7.

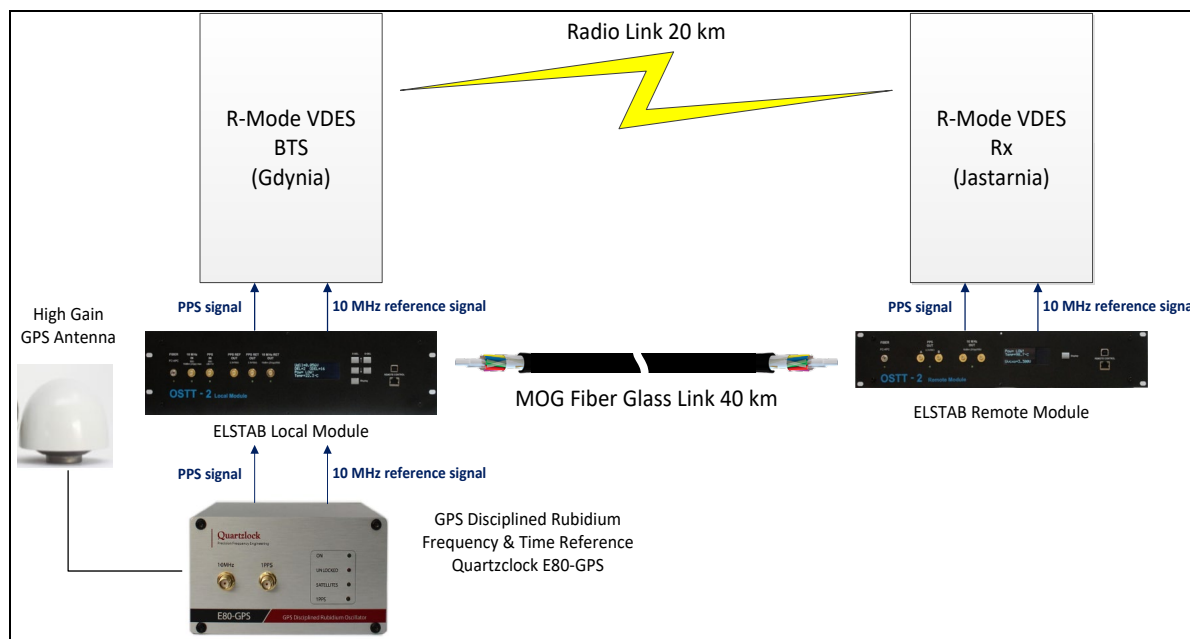

Fig. 6.7 Block diagram of the equipment for F/T transfer from Gdynia to Jastarnia using fiber optic cable.

In the Port of Gdynia, the VDES transmitter equipped with an atomic clock as the time and frequency source was installed at the Navigational Monitoring Center in Gdynia port - see also Chapter 6.1.

In the Jastarnia boatswain's house, there is a VDES receiver whose atomic source of time and frequency we want to replace by F/T transfer via fiber optic using the ELSTAB system devices.

The VDES transmitter and receiver communicate by a radiolink in the VHF band; in a straight line (LOS) the range is about 20.4 km. The ELSTAB Local unit will be mounted as close as possible to the GPS disciplined VDES transmitter's time source in Gdynia and should be connected by short cables to receive 1PPS pulses and 10 MHz frequency. The output of the ELSTAB Local unit will be connected to the input of the fiber optic cable connecting Gdynia with Jastarnia (via Hel). The total length of fibre optic line is approximately 40 km. In Jastarnia, the ELSTAB Remote receiving unit will be installed at the VDES receiver and the 1PPS and 10 MHz signals will be connected via separate cables to the VDES receiver unit input. In this way the receiver's atomic rubidium generator will be replaced by signals transmitted via optical fibre cable.

It should be noted that one needs to investigate if the ELSTAB can be used with a rubidium oscillator as the frequency source. Those oscillators can be "noisy" in the short term which may interfere with the internal loops of the ELSTAB.

The purpose of the test will be:

- the verification of the possibility to transfer time and frequency from Gdynia to Jastarnia with a set time difference accuracy of <math><10\text{ ns}</math>, with the elimination of the atomic standard in Jastarnia. This would require some sort of calibration actions, like using the GNSS carrier phase receiver or external reference clock etc.
- performing distance/range measurements (accuracy, stability) on the Gdynia-Jastarnia line using VDES signals and a common time source,
- in the future, long-term F/T transfer stability maritime measurements can be carried out using the ELSTAB technique.

7 Conclusions

- Based on the review of the F/T transfer techniques, recognition and the availability of the necessary equipment, the ELSTAB technique and technology developed by AGH University of Science and Technology in Krakow was selected.
- The inventors of this method declare their willingness to participate in the tests of the fiber-optic network between Gdynia and Jastarnia and will also provide and install the appropriate equipment.
- The UMG declares its readiness to carry out the technical adaptation of the existing transmission path and the measurements of its transmission parameters. It is possible to perform joint calibration and then carry out the time and frequency accuracy transfer tests on the Gdynia - Jastarnia section.
- The remaining task is to estimate the costs of the undertaking and to find a source of financing.

8 References

- [0] WP3.1 Baseline and Priorities, document R-Mode Baltic, GA3.0, - July 2019
- [1] Sources of Time and Frequency. The Present State and Directions of Development, by Antoni Masiukiewicz, KNUV 2017
- [2] Best Practices for Improved Robustness of Time and Frequency Sources in Fixed Locations, Document of US Homeland Security, 2015
- [3] Selection and Use of Time and Frequency Sources for all Systems, US DOT, for FAA 2020, <https://www.faa.gov/document>
- [4] Enhancing Accuracy and Robustness of Frequency Transfer Using Synchronous Ethernet and Multiple Network Paths, by Mattia Rizzi, Stefano Rinaldi, Paolo Ferrari, Alessandra Flammini, IEEE TRANSACTIONS ON INSTRUMENTATION AND MEASUREMENT, VOL. 65, NO. 8, August 2016.
- [5] IEEE Standard for a Precision Clock Synchronization Protocol for Networked Measurement and Control Systems, IEEE Standard 1588, Jul. 2008, pp. 1–269.
- [6] A review of time and frequency transfer methods, by Judah Levine, Time and Frequency Division, National Institute of Standards and Technology, Boulder, CO 80305, 2008 USA
- [7] NTP/PTP/White Rabbit Synchronizing Time Over Secure Networks, Orolia 2020, TP/www.orolia.com
- [8] ELSTAB—Fiber-Optic Time and Frequency Distribution Technology: A General Characterization and Fundamental Limits, Przemysław Krehlik, Łukasz Śliwczyński, Łukasz Buczek, Jacek Kołodziej, and Marcin Lipinski, IEEE TRANSACTIONS ON ULTRASONICS, FERROELECTRICS AND FREQUENCY CONTROL, VOL. 63, NO. 7, JULY 2016
- [9] ELSTAB Technology, Łukasz Śliwczyński and Przemysław Krehlik, AGH University of Science and Technology, CLONETS – Clock Network Services, Horizon 2020-grant agreement no. 731107
- [10] THEWHITE RABBIT PROJECT, J. Serrano, P. Alvarez, M. Cattin, E. Garcia Cota, J. Lewis, P. Moreira, T. Wlostowski, CERN, Geneva, Switzerland, Proceedings of ICALEPCS2009, Kobe, Japan
- [11] Rubidium oscillator data , NIT, OEM GPS Disciplined Rubidium Oscillator (MRX)
- [12] Timing Reference Sources, Marc A. Weiss, Ph.D. Time and Frequency Division National Institute of Standards and Technology, mweiss@boulder.nist.gov
- [13] AIS AND VDES RANGING – MEASUREMENTS RESULTS, GA5.3/5.4 project report, NIT, 2020
- [14] VDES R-MODE POSITIONING SYSTEM DEMONSTRATOR, GA5.3/5.4 project report, NIT, 2021