

AmiNIC Breathalyzer

Experts in Teams

Technical Report

Arthur Blaser
Arune Lapinskaite
Boris Kacer

Cadence Andersen
Carlos Moyá Gual
Lucas Weber

Oskar Skoczylas
Richard Jenis
Tobias Schult

AmiNIC Breathalyzer	1
1 Introduction	4
1.1 Problem formulation	4
1.2 Potential Fields of Application	4
1.3 Scope	4
1.4 Success Criterion & Constraints	5
1.5 Constraints	5
2 Work structure	6
2.1 Intro	6
2.2 Group roles	6
2.3 Time management & work distribution	6
2.4 Risk Management	7
2.5 Quality Management	9
2.6 Communication & Stakeholders	10
3 Electronics Design	11
3.1 Introduction	11
3.2 Device Algorithm	11
3.3 Generating the sweep	13
3.4 Measuring the current response	15
3.5 Research	17
3.6 Components Selection	23
3.7 Tasks	26
4 Chemical design	30
4.1 Objective:	30
4.2 Methods	30
4.3 Results	31
4.4 Discussion	33
5 Mechanical Design	34
5.1 Design Overview	34
5.2 Introduction	34
5.3 Testing Setup	35
5.4 Technical Research	36
5.5 Individual parts	38

6	Business Research	48
6.1	Intro	48
6.2	Competition Analysis	48
6.3	Customer Research	56
6.4	Interactive Prototyping	61
7	Conclusion	65
7.1	Future Implementations	65
7.2	Summary	66
8	Appendix	67
8.1	Work Breakdown structure	67
8.2	Activity Node Network	68
8.3	Gantt Chart	69
8.4	Risk Response Matrix	70
8.5	Battery Performance Graph	71
8.6	Reaction mechanism between methyl red and aldehyde.	71
8.7	Chemical risk assesment.	72
8.8	Teensy code	72
8.9	List of the companies	79
8.10	Questionnaire answers	79

1 Introduction

1.1 Problem formulation

When the pandemic hit the world, including Denmark, the use of plastic in medical industry has rapidly increased. The usage of single-use gloves, and masks have been the main factors that caused this phenomenon, followed by increased use of packaging and single-use tests. This project intends to help revert the trend of single-use tests which have taken part in increased emissions and plastic waste and be one of the new and innovative emerging alternatives. This solution will be achieved by creating a Breathalyzer device that can detect selected chemical compounds in gases emitted in one's breath and present the result on a mobile interface. Moreover, keeping the solution reusable and therefore the price per use competitive is one of the goals as well. Aminic Breathalyzer will create an alternative to the other types of tests, hence, providing more freedom to the customers/users when choosing how to assess the infection.

1.2 Potential Fields of Application

The first potential field is aiming to provide a competitive alternative to Antigen tests (quick tests) used by healthcare providers in Denmark. The second potential field aims at companies that require employees to be on-site to conduct their work. These are the companies that can only function when employees are on-site doing their jobs, otherwise, the business could not function. For instance, companies that use machinery that needs an operator present or use assembly lines that need workers to perform on-site. The only way to avoid a shutdown has been to have employees tested regularly or when needed to stop a potential spread of the infection.

A market poll was conducted among multiple companies and departments, regarding Covid19 testing procedures and the potential use of the Breathalyzer. It has shown that 50% of the companies require their non-vaccinated employees to be tested regularly. For companies that do not provide on-site testing, 60% agreed that implementing such a method at their workspaces would be a good idea. A full questionnaire analysis can be found 6.4.

In a conclusion, the Breathalyzer can serve as a tool to reduce the use of companies' resources by having the employees tested on-site with immediate results. This would eliminate the need for workers to travel to the nearest test centres and their compensation, and it would make it easier for a company to stop a potential spread early on.

1.3 Scope

With the recent identification of ethanal (acetaldehyde) as a COVID-19 breath biomarker¹, the detection of infection through breath is possible. As ethanal detection in human breath can also describes other lungs infections disease, conventional testing such as PCR must be performed to confirm COVID-19 infection. However, this recent discovery open doors to the development of molecular weighting sensor (e-nose technology) for prior screening of potentially COVID -19infected population.

The project covers a full physical prototype with working electronics and a comprehensive business plan. In addition, a technical report along with proof of concept must be delivered at the end of the project period. That includes a user guide with a product presentation.

¹ RUSZKIEWICZ, Dorota M., SANDERS, Daniel, O'BRIEN, Rachel, *et al.* Diagnosis of COVID-19 by analysis of breath with gas chromatography-ion mobility spectrometry-a feasibility study. *EClinicalMedicine*, 2020, vol. 29, p. 100609.

The project itself is divided into three main branches, helping to coordinate the work and state the objectives, etc. All major tasks have been defined and planned using various management methods covered in section 2.

The project does not include further development of piezoelectric membranes for other diseases or viruses. In this case, the sensor membrane will be coated with COVID-19 bounding material only. Nevertheless, the device will be engineered allowing the usage of different membranes (application of other coatings) and adapting the detection method for other substances.

1.4 Success Criterion & Constraints

To achieve a successful project, the team has to:

- Test the piezoelectric membranes coated with COVID-19 bounding material and prove that the chemical compound specific to a person positive with COVID-19 sticks to it, changes the frequency of the sensor, and thus proves the result
- Develop the right electronics to acuate and process the sensor's data
- Develop a physical device prototype, with a working user interface,
- Deliver a vital product suitable for a market with all customer's needs satisfied, and own competitive advantage over the competition

The Success Criteria can be measured by:

- Proof of Concept
- Measuring the frequency of the sensor and tracking the change when the gases are in proximity with the membrane. A change in frequency would mean the compound successfully stuck to the membrane.
- The device is tested by potential users, prototype reviewed to be mobile and relatively simple to use
- Satisfying customer's needs while keeping the competitive edge
- Sales Revenues and Net Profit would be a good indicator of whether the product is successful or not

1.5 Constraints

The general limitations of the project can be presented in three categories:

- 1) Physical
 - a. The device must be mobile
 - b. allow easy transportation (e.g., fit in a human's hand)
- 2) Financial
 - a. Budget 10,000 DKK
- 3) Human
 - a. Limited knowledge of the chemical aspect of the sensor (detected gasses)
 - b. Limited number of engineers
(6 Mechatronics, 2 Electronics, 1 Innovation & Business)
 - c. Limited working time



2 Work structure

2.1 Intro

AmiNIC Breathalyzer is an Adaptive project. The overall goal is known, however, there are too many unknowns to specify a fixed roadmap. The workflow plan will be adapted along the way.

We will be using Scrum as an iterative model for our project. The Scrum board will be updated each meeting and will help to keep the work structure and track its progress. This way every step of the work is layered and the final decision on design, business plan, and other parts of the project scope can be done as late as possible. It will help the team to go through all the options available and be critical while doing so.

2.2 Group roles

Boris Kačer	<i>Innovation & Business</i>	Group Manager - Full Business Research
Oskar Skoczylas	<i>Mechatronics</i>	Group Manager - Work structure, mechatronics & business support
Carlos Moyá Gual	<i>Mechatronics</i>	Support Development - Programming, Testing setup, Battery Indicator
Cadence Andersen	<i>Mechatronics</i>	Peak detection Development -Current response
Arthur Blaser	<i>Mechatronics</i>	Coating development - Chemical Design
Lucas Weber	<i>Mechatronics</i>	Mechanical Design -Full device, Cartage Design
Richard Jenis	<i>Mechatronics</i>	Mechanical Design - Testing setup, Ergonomic Handle, Cartage Design
Tobias Schult	<i>Electronics</i>	Embedded Design -Programming, Electronics
Arúne Lapinskaite	<i>Electronics</i>	Embedded Design -Programming, Electronics

Table 2-1 Group roles

2.3 Time management & work distribution

Work Breakdown Structure

Since the project doesn't have a fixed initial plan, a WBS will be created.

Consequently, the project can be broken into parts/modules, and people can be assigned to specific areas.

A detailed version can be seen in Work Breakdown structure.

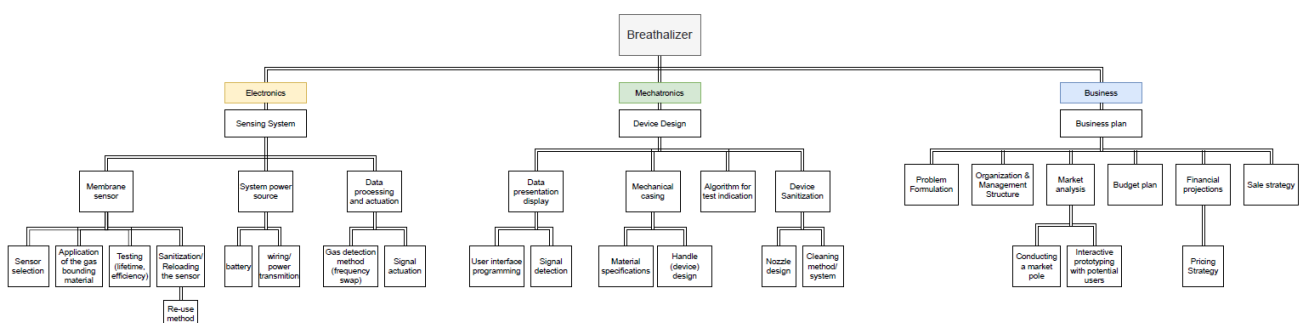

Figure 2.1 WBS - Small Chart

Gantt Chart

Included in Appendix Gantt Chart.

Activity Node Network

All major tasks were put in a table allowing to state all preceding activities and their completion time. Consequently, an Activity Node Network was created and used to calculate the Critical Path of the project. Full Activity Network diagram included in the Activity Node Network.

Activity	Description	Preceding Activity	Activity Time (days)
0.0	Intro Research		7
1.A	Sensor Selection*		10
1.B	Application of the gas bounding material	1.A	10
1.C	Testing the membrane	1.B	22
1.D	Sensor Sanitization/ Reloading/ Re-use method	1.C	10
1.E	System Power Source: Battery & Wiring**	1.C	20
1.F	Frequency Sweep data processing**	1.C	22
1.G	Signal actuation and indication**	1.F	30
2.A	Signal detection & User Interface	1.G	30
2.B	Material specifications & Selection*		5
2.C	Handle Design	2.B	14
2.D	Nozzle selection & Design	2.B	22
2.E	Cleaning System/ Re-use method	1.C, 2.C, 2.D	15
2.F	Final Device Assembly	2.A, 2.E, 1.E, 1.D, 1.G	15
3.A	Problem Formulation***	3.C, 3.B	13
3.B	Organization Structure***	1.A, 2.B	5
3.C	Market Analysis	1.A, 2.B	15
3.D	Budget Plan	3.A,	5
3.E	Financial Projections & Pricing	1.E, 2.E, 3.A	22
3.F	Sale Strategy	3.E, 3.D	5
3.G	Market Pole, Interactive Prototyping	3.C	14
3.H	Business Plan Formulation	3.G, 3.F	42
3.I	Final Product Decisions	2.F,	6
3.J	Presentation Pitch	3.H, 3I	6

Table 2-2 Activity Table

$$\text{Critical Path} = 7 + 10 + 10 + 22 + 30 + 15 + 6 + 6 = 106 \text{ days}$$

106 days \approx 4 months

The Project should be completed within the timeframe, even considering the worst – case scenario.

2.4 Risk Management

Risk Identification

- a) Technology is not able to deliver set requirements, i.e.:
 - membrane does not bound the gas
(sensor can't detect Covid-19)
 - unsuccessful data processing from the sensor
(microprocessor insufficient to analyze high-frequency output)

- b) Device too advanced to achieve mobility
- c) Unwanted complexity - caused by adding unnecessary features
- d) The unreliable operation, the device requires a lot of effort and time
- e) Device not suitable for the market
 - not satisfying the customer's needs,
 - unfeasible production due to cost
- f) Budget overrun
- g) Project delivery time overrun
- h) Communication issues - the team fails to cooperate resulting in an incomplete project (lack of final physical built)

Likelihood	5					
	4					
	3		Unreliable operation (d)	Device not suitable for the market (e)	Technology not able to deliver set requirements (a)	
	2		Device too advanced to achieve mobility (b)	Budget overrun (f)	Project delivery time overrun (g)	
	1	Communication issues (h)	Unwanted complexity (c)			
		1	2	3	4	5
		Impact				

Table 2-3 Risk Matrix

The risks above can be mitigated by staying critical, monitoring the progress, and clear reasoning all decisions. Every new development must be reviewed in regards to the scope and project requirements. Such actions would lead to a finished mobile product that is suitable for the medical market (as defined in the initial requirements).

Due to limited expertise, selected components might not meet the expectations. It is important to validate each choice with the supervisors and experienced engineers.

Budget and time overrun risks will be minimized by project managers, who will constantly oversee and document the progress, tasks, and expenses. In this process, step-by-step workflow is essential. A Scrum board integrated with an online team management software will be used on daily basis to achieve an organized project structure.

Most miscommunications can be avoided with a clear project plan and an involved team. Team members have to respect each other, document their work progress, and stay up to date with the tasks and messages in the group chat. In addition, everybody should keep a friendly attitude, listen to all ideas and try to solve any conflicts in a calm mature way.

- 1) Stay Critical
- 2) Reason and document all product development choices
- 3) Monitor the progress:
Tasks (SCRUM - To Do, In Progress, Done), Costs (Current expenses and budget)
- 4) Validate each technology decision (Supervisors)
- 5) Be respectful and stay up to date with the group.

A full table with detailed risk response strategies can be found in Risk Response Matrix.

2.5 Quality Management

To achieve the desired quality in your project, consider the following:

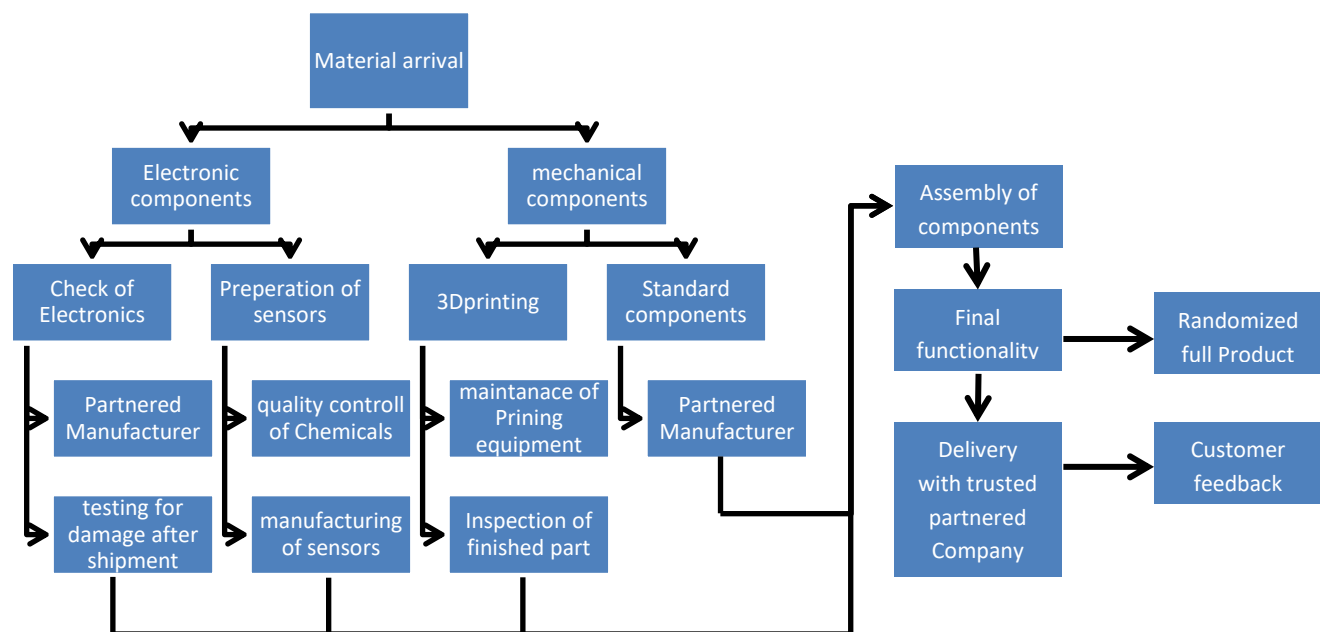

Figure 2.2 Quality Management Diagram

Quality control starts at the very first steps. The procurement of the required materials for our Production. We make sure to have stable and positive communication with our partners. Through contracts and reliable payment, we want to make sure that our partners are willing to take care and deliver their parts exactly as we required. Once we receive the Materials, we will give them to the responsible personnel for further inspections down the assembly line. This would mean the following during manufacturing:

- The electronic department handles all aspects dealing with electronic component
 - Preparation of Sensors
 - The Sensors will be coated by a special in house produced chemical compound, Post application they will be undertaking a brief test on a dedicated testing rig
 - The chemical coating will be in-house produced with partner companies for the base ingredients. To ensure its effectiveness ness each batch will be sampled and tested in the lab.
 - Electronic components
- The mechanical department deals with every aspect of the mechanical side of things
 - Standard components,
 - Incoming standard components (nuts, bolts, etc.) are mostly quality assured by the manufacturer but will be visually inspected by staff before/during final assembly

- 3D-Printing department
 - Taking care that the incoming filament is properly treated, of the right kind, and within humidity standards
 - Regularly maintaining the 3D-Printers, calibrating, and ordering replacement parts ahead of expected wear out.
 - Maintenance and operational staff are the same, allowing to inspect the printed parts and calibrate the machines according to the observed imperfections

- Assembly and final testing
 - During the assembly of components, we will make sure all components are installed with a checklist, ensuring that no components are forgotten
 - After initial assembly, a quick test is run to see if all electronic components have been correctly installed and set up.
 - Randomized tests will pick a finished device after assembly to test its full capability, seeing if there have been faults with the product.
 - After assembly, the finished product is packed and then either brought to a warehouse or directly shipped to the customer via a partnered shipping company

2.6 Communication & Stakeholders

Communication Plan

Description	Frequency	Channel	Audience	Owner
Project Status Updates	Weekly	In person	Internal stakeholders & project team members	Project Manager
Virtual Team Meetings	As needed	Zoom	All project team members	Person calling for the meeting
External Stakeholders Meetings	Quarterly	In person	Project manager & external stakeholders	Project Sponsor
Milestone & deliverables	Monthly	In person	Project team	Project Manager
Project Check-ins	Daily	Project Management Platform	All stakeholders	All stakeholders

Table 2-4 Communication Plan

Project Stakeholders

Stakeholder analysis		Project		
Stakeholder	Expectations/ Success criteria	Contribution	Power	Need of attention
Customer	Buying the device	Provides ROI	High	Customer feedback
Project Team	Delivering functional device	design, development, manufacturing,	High	Weekly meetings, updates
Investors	Positive ROI	Provides initial capital	Medium	Quarterly numbers, sales projections

Table 2-5 Project Stakeholders

3 Electronics Design

3.1 Introduction

The simplified electrical system is represented on the figure 4.6.

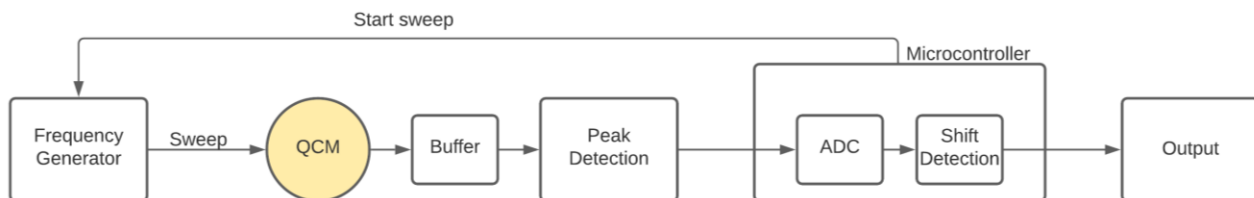

Figure 3.1 Abstract of electrical system

The Breathalyzer is controlled using two microcontrollers. The Arduino, which is used to write to the registers and control the frequency generator and the Teensy. The teensy is used for fast sampling, data processing and the control of the user interface as well as the Arduino. The frequency shift detection can be implemented with two different methods. One method is using a Fast Fourier Transform (FFT). This way the resonance frequency and its amplitude can be found. The second method is using a peak detection circuit, which detects the highest voltage at the resonance frequency. In both methods at the start-up of the system, first, the Arduino writes into the registers of the frequency register. Then the system is ready to be used. When the button then is pressed the frequency generator and the ADC is started. The frequency generator sends out a sinusoidal frequency sweep. A frequency sweep is the increase of frequency over time. This way the sensor gets excited with different frequencies. When a frequency from the sweep matches the resonant frequency of the sensor it will oscillate stronger and that will be detected by either of the before mentioned methods. After the first execution, the code on the teensy will determines the resonance frequency and use it as a reference. After the second execution, the teensy is comparing the two results and giving an output.

3.2 Device Algorithm

The device required a working principal algorithm, which at the same time would serve as an operational manual / user guide.

The user interface consists of a trigger button and 3 indicator LEDs. Simplicity was the right approach since, in the conducted questionnaire, over 60% of companies chose a basic UI indication versus an advanced one (LCD display etc).

The following flowchart shows the whole measurement process, including device set up and sanitization, all the way to the result.

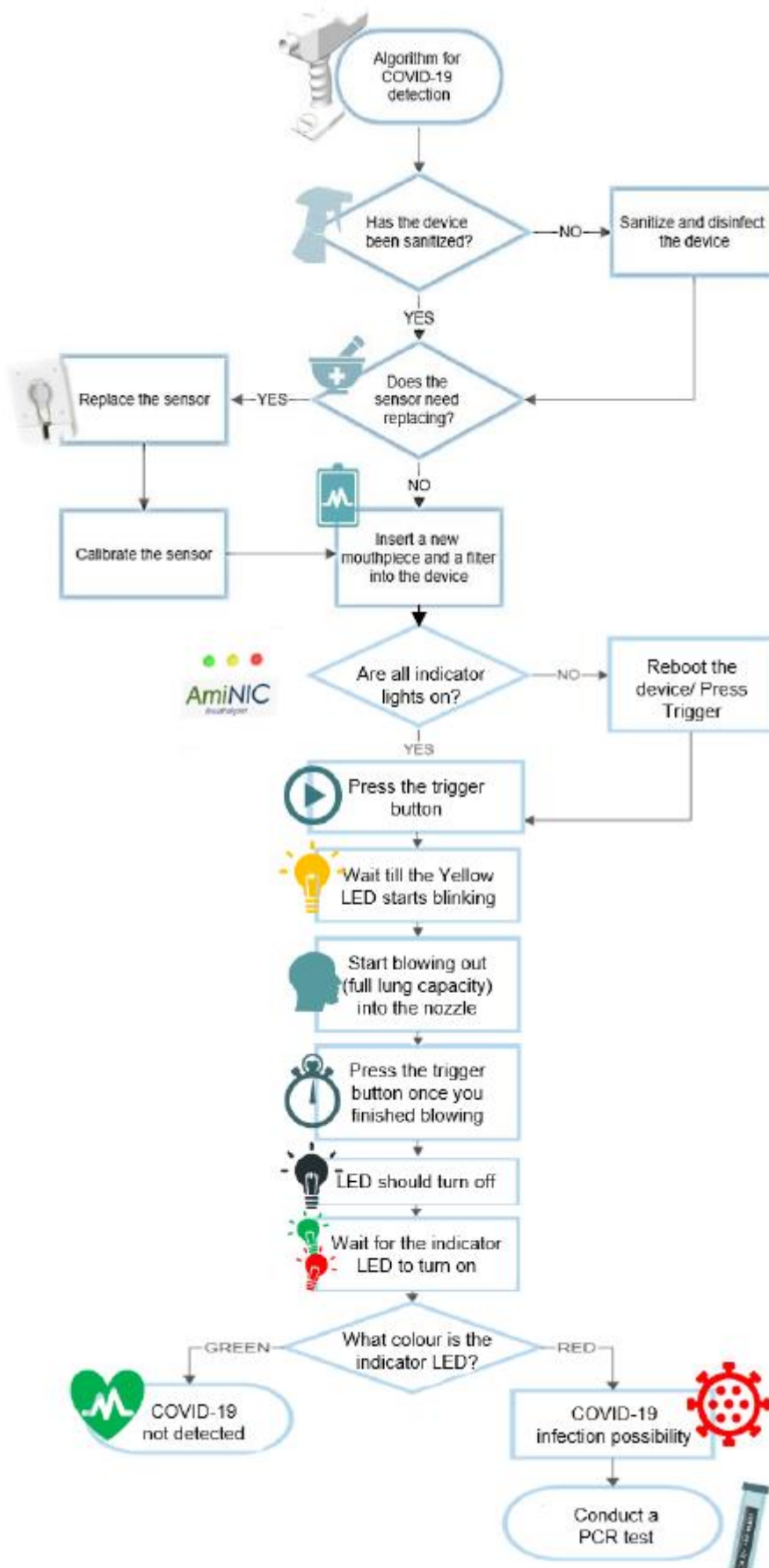

Figure 3.2 Test Diagram

3.3 Generating the sweep

For the frequency sweep, the Waveform generator AD5932 is used. The sweep is configured to iterate in the region of 4.998MHz to 5.01MHz to hit the resonant frequency of the QCM piezo membrane which is around 5MHz. This range has also worked well using the impedance analyzer during testing and research. The step size is set to be 3Hz with 4000 increments for high resolution taking a span of 12000Hz. The time for each increment is set to be 40 μ s, so the total sweep takes a total of 16ms to complete.

3.3.1 AD5932 and Setup

The AD5932 is written via a 3-wire SPI communication which operates at clock rates up to 40 MHz. For the SPI communication, the pins of AD5932 SCLK are connected to Arduino SCK, SDATA to SDA, and FSYNC to D7. The device operates with a power supply from 2.3 V to 5.5 V and uses an external Oscillator of 50MHz.²

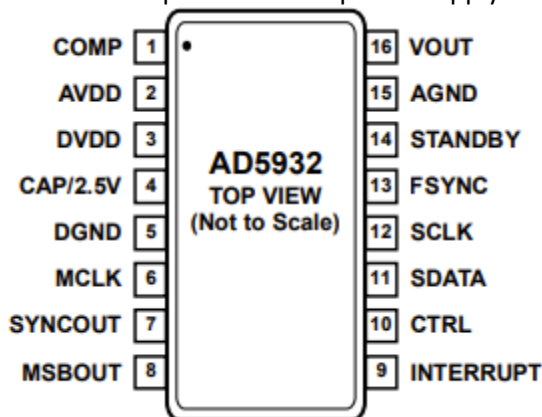

Figure 3.3 AD5932²

In the test set up 2 decoupling capacitors in parallel of 100nF and 2.2 μ F are used between the ground and VCC for the 50MHz oscillator. The two 100nF decoupling capacitors are connected between AVDD, DVDD, and AGND, DGND. According to the datasheet, the regulator requires a decoupling capacitor of typically 100 nF, which is connected from CAP/2.5V to DGND.²

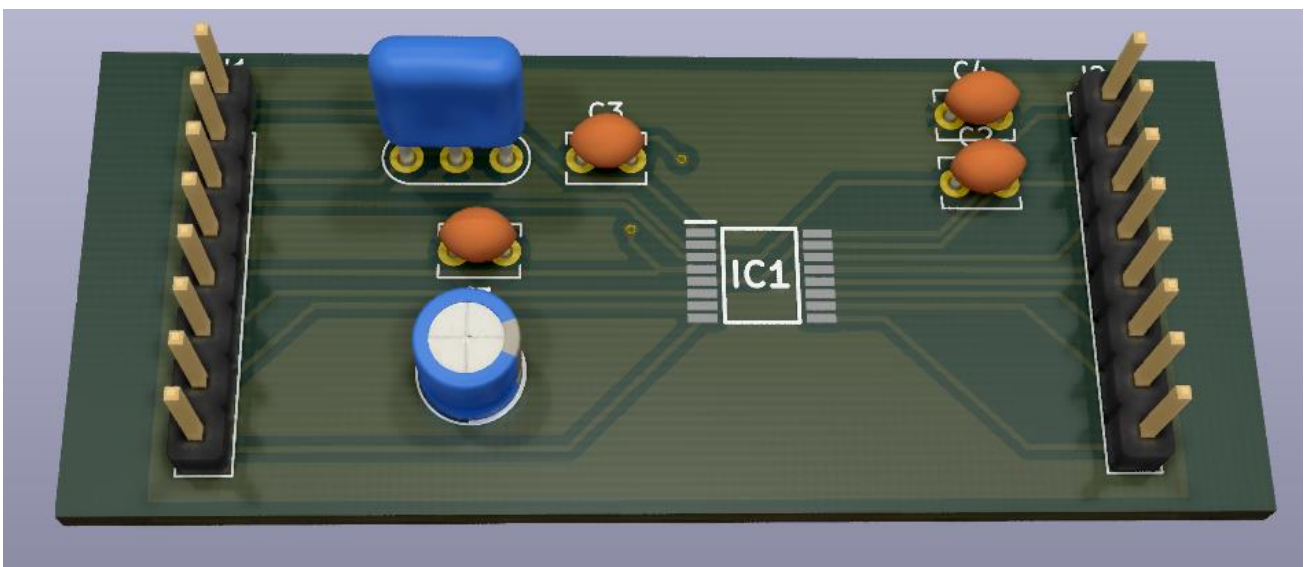

Figure 3.4 Waveform Generator with Oscillator PCB Test Setup

² Analog Devices "Programmable Frequency Scan Waveform Generator Rev. C" April 2017

3.3.2 Code

Data is loaded into the device as a 16-bit word under the control of a serial clock input, SCLK. FSYNC acts as a frame Synchronization and chip enable. To program the AD5932 first FSYNC is pulled LOW and the data is shifted into the device's input shift register on the falling edges of SCLK for 16 clock pulses through the SDATA line. FSYNC should only go high after the 16th SCLK falling edge of the last word is loaded. The AD5932 is designed to provide automatic frequency scans when the CTRL pin is triggered. The scan is controlled by a set of registers and their addresses. First, the CTRL register is loaded as a 16-bit word, by sending the 8 MSB first and then the remaining 8 LSB. In the CTRL register bit, D5 is set to zero to trigger the frequency increments automatically, and the bit D9 is set to one for the sine waveform.³ The rest of the bits are kept default by the datasheet.

Register Address				Mnemonic	Name
D15	D14	D13	D12		
0	0	0	0	C _{REG}	Control bits
0	0	0	1	N _{INCR}	Number of increments
0	0	1	0	Δf	Lower 12 bits of delta frequency
0	0	1	1	Δf	Higher 12 bits of delta frequency
0	1			t _{INT}	Increment interval
1	0				Reserved
1	1	0	0	F _{START}	Lower 12 bits of start frequency
1	1	0	1	F _{START}	Higher 12 bits of start frequency
1	1	1	0		Reserved
1	1	1	1		Reserved

Next, the start frequency is loaded which takes up a total of 2 registers, where the first 4-bits are the address, and the remaining 12-bits are for the LSB and MSB of the frequency word. To calculate the frequency word M the formula is used³:

$$M = f_{out} * 2^n / f_{MCLK}$$

Where:

f_{out} = desired start frequency,

n = 24 bits, the resolution of the on-chip accumulator,

f_{MCLK} = 50Mhz, external CLK frequency,

Then this value must be separated into the F_{start} MSB and F_{start} LSB in binary.

The frequency increment is set in the same way using the formula from above where f_{out} is the desired delta frequency.

³ Analog Devices "AN-1044: Programming the AD5932 for Frequency Sweep and Single Frequency Outputs (Rev. A)" 8/2009, Revision 11/2010

The Number of increments is a 12-bit data register, where the maximum number of increments is 4095.

D11 to D0	Number of Increments
0000 0000 0010	Two frequency increments. This is the minimum number of frequency increments.
0000 0000 0011	Three frequency increments.
0000 0000 0100	Four frequency increments.
...	...
1111 1111 1110	4094 frequency increments.
1111 1111 1111	4095 frequency increments.

Since the increments are set to occur automatically in the CTRL register, the increment interval (t_{INT}) must be set as well. The increment dictates the duration of the DAC output signal for each individual frequency of the frequency scan. The AD5932 offers two options for duration, where the duration is a multiple of cycles of the output frequency or a multiple of MCLK periods.

For this project, the duration is set to be a multiple of MCLK periods, since it gives a wider range of use. For the MCLK we have an external oscillator of 50Mhz, with a period of 20ns, so if we want 40 μ s of duration for each individual frequency, the value must be set to be 2000 in binary. Which gives out 20ns*2000=40 μ s. In order to calculate the end frequency we use the formula:

$$f_{end} = F_{START} + N_{INCR} * \Delta f$$

For the duration of the whole sweep:

$$t_{duration} = t_{INT} * N_{INCR}$$

3.4 Measuring the current response

Finding the resonance point of the crystal requires estimating the transfer function between voltage and current. In the current iteration, this is done by directly measuring the voltage over a shunt resistor, since that is proportional to current passing through the system, then using a peak detector to find the amplitude of the signal.

3.4.1 Amplifier stage

The first stage in the response measurement circuit is an amplifier stage. This is necessary for two reasons: The voltage over the shunt resistor can easily drop below a millivolt, and the high impedance of the amplifier helps to keep the circuitry of the peak detector from influencing the transfer function of the crystal.

The amplifier stage consists of three AC-coupled inverting op-amp stages, each with a gain of up to 10, and a trim resistor to lower the gain if needed.

3.4.2 Peak detector stage

The second stage is the peak detector, which obtains the amplitude of the signal passed into it.

The first half of the circuit approximates a current-booster ideal diode. Both transistors act as diodes that boost any current passing through the base to the emitter, which allows even faster charging of the capacitor. The output transistor makes sure current can only flow one way through the circuit. The transistor

connected to the inverting input of the op-amp keeps the circuit symmetrical, such that the voltage on the output will be approximately equal to the voltage on the inverting input.

Since the first half of the circuit acts as an ideal diode, the capacitor will charge up very quickly when the voltage over it is less than the voltage input to the circuit, but discharge slowly through the resistor when the voltage over it is higher, giving a voltage over the capacitor equal to the peak voltage on the input of the circuit. This value is then buffered by an inverting amplifier giving an output to be recorded by the ADC (and inverted again digitally).

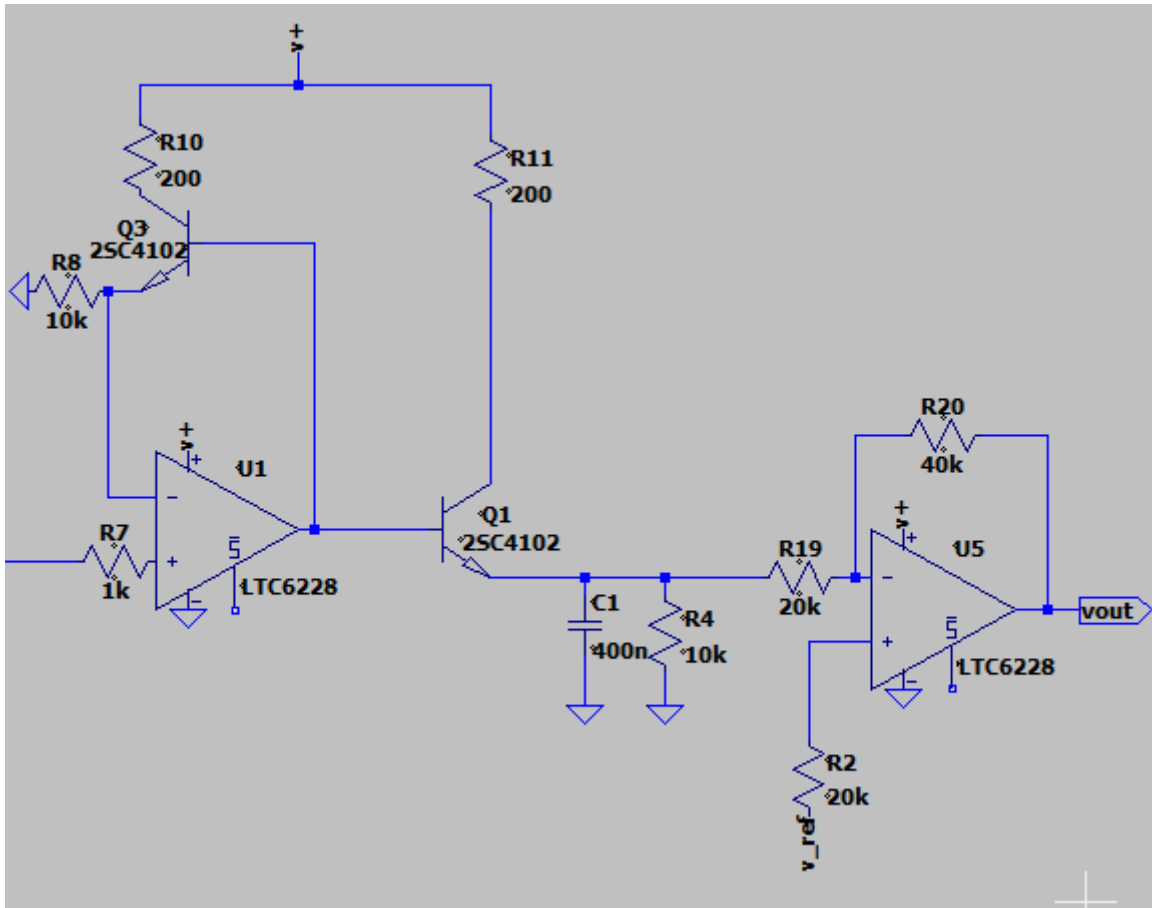

Figure 3.5 Peak Detection Schematic

3.4.3 Issues and improvements

The biggest limiting factor of this circuit is that due to the very high quality factor of most crystals, noise from just turning on the frequency sweep can excite the crystal for the entire sweep. This makes timing difficult since the noise resonating around in the crystal will form a beat with the frequency sweep, making it hard to precisely separate the peak caused by resonance with the frequency sweep from the peak of a beat.

One way around this could be to replace the peak detector with a simple spectral analyser or a fast (15-100Mhz or more) ADC and measure the frequency peak directly.

3.5 Research

3.5.1 Background study

Piezoelectricity is the phenomenon when electric charge is generated in certain solid materials such as crystals, certain ceramics, and biological matter. The materials need to have a certain internal structure.

The structure of a crystal is represented in the figure 3.6.

What can be seen are dipoles of silicon and oxygen.

At a resting state, the dipoles are balancing each other out due to their symmetry. This results in a neutral charged crystal. When a stress is applied to the crystals, the dipoles get out of balance. This causes the dipoles to generate momentum, which creates an electrical field across the crystal and vice versa.

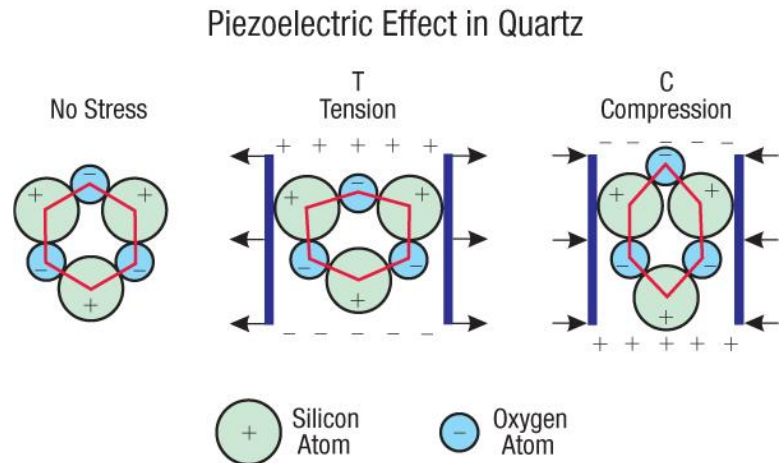

Figure 3.6 Crystal structure

A single-crystal material, prefers an alternating signal. It is best suited due to its internal impedance.

Single-crystal materials have a lower piezoelectric constant. The piezo constant describes the volume change when applied an electric field. On the other hand, single-crystal materials have high stability and temperature resistance.

Quartz crystal microbalance (QCM) is a single pure quartz crystal. It has a very high Q-factor or Quality factor. The Q-factor describes the frequency to bandwidth ratio. Resonator with a high Q-factor which are driven by a sinusoidal signal will have a greater amplitude at the resonant frequency but have a smaller range of frequencies around the resonant frequency. ⁴

QCM sensors are very common for measuring a change in mass per area. This is done by measuring the change of resonance frequency of the quartz due to the added weight.

Using the Sauerbrey equation it is possible to determine the sensitivity of the QCM sensor.

$$\Delta m = -C * \frac{1}{n} * \Delta f$$

Δm = mass change,

C = constant that depends of the property of the crystal ,

n = overtone number,

Δf = frequency change,

⁴ https://www.researchgate.net/publication/292834666_Potential_of_Piezoelectric_Sensors_in_Bio-signal_Acquisition

Information from the manufacturer states ⁵

An AT-cut 5MHz quartz crystal by room temperature has a $C \approx \frac{17.7ng}{cm^2 * Hz}$. This results in $17.7 \frac{ng}{cm^2}$ of mass on a 5MHz sensor causes 1Hz of change.

The formula is valid to use for as long as it full fills the Sauerbrey equation condition

1. “The added mass is small compared to the mass of the crystal itself
2. The added mass is rigidly adsorbed
3. The mass is evenly distributed over the active area of the crystal” ⁶

The best model for simulation is the Butterworth Van Dyke (BVD) model since it is a classical model for a piezoelectric actuator and is often referred to in literature about QCM sensors. The equivalent circuit is represented in the figure 3.8.

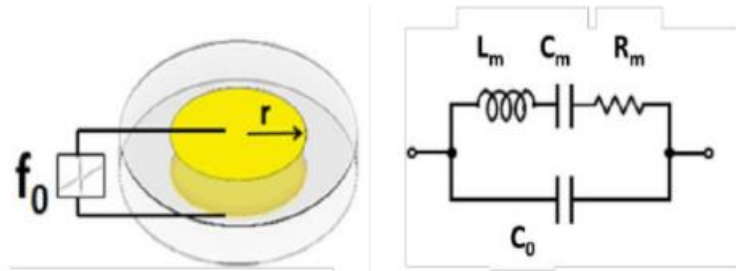

Figure 3.8 Piezoelectric actuator

The circuit can be divided into the components of the motion:

$R_m =$ The motional resistance ,

$L_m =$ The motional inductance,

$C_m =$ The motional capacitance,

$C_0 =$ The shunt capacitance of a crystal,

The motional inductance is the mechanical mass of quartz in motion.

The motional capacitance is the stiffness of the quartz.

The motional resistance is the resistive element of the quartz.

The shunt capacitance is the storage element of the pads of the sensor.

$$C_0 = \frac{e_p * A}{h}$$

$$C_m = \frac{8 * K_0^2 * C_0}{(N * \pi)^2}$$

$$L_m = \frac{1}{w_{MSRF}^2 * C_m}$$

$$R_m = \frac{n_p}{c_p * C_1} \left(\frac{w}{w_{MSRF}} \right)^2$$

⁵ <https://www.nanoscience.com/techniques/quartz-crystal-microbalance/#sauerbrey>

⁶ <https://www.nanoscience.com/techniques/quartz-crystal-microbalance/#sauerbrey>

$K_0 =$ Piezoelectric electrochemical constant,

$c_p =$ Piezoelectric material elastic constant,

$e_p =$ Piezoelectric material permittivity,

$h =$ Crystal Electrodes separation,

$N =$ Odd harmonic overtone ($N = 1, 3, \dots$),

$w =$ operating frequency,

$w_{MSRF} =$ Motional Series Resonance Frequency,

$n_p =$ Viscosity,

$A =$ Effective Surface Area,

When these values are known it is possible to calculate the BVD model. Due to various constants the model did not get calculated by the group. The values got found by research and were for the needs sufficient enough.¹

$$C_0 = 20pF$$

$$C_m = 33fF$$

$$L_m = 30mH$$

$$R_m = 10\Omega$$

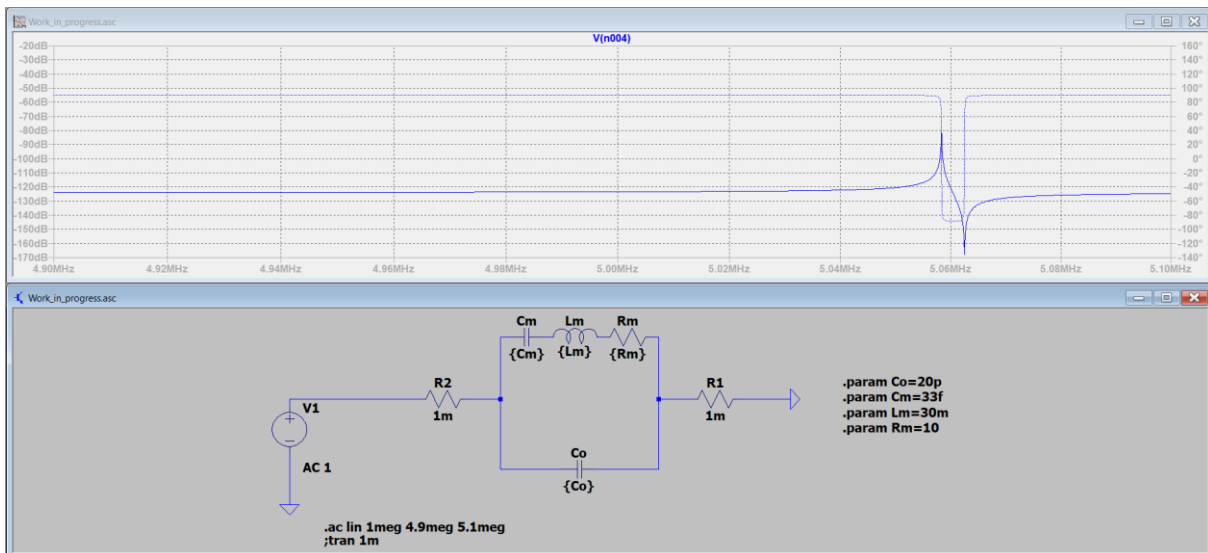

Figure 3.9 LT-Spice

Presented in Figure 4.3 is the BVD model of a simple QCM crystal at around 5MHz the deviation is due to rounding. This model is a basic model. It can be extended like seen on Figure 4.4.

The model only represents odd harmonics since they are the only once which get excited electrical when the sensor is observed at the appropriate frequency.

$L_m =$ The mass added to the surface ,

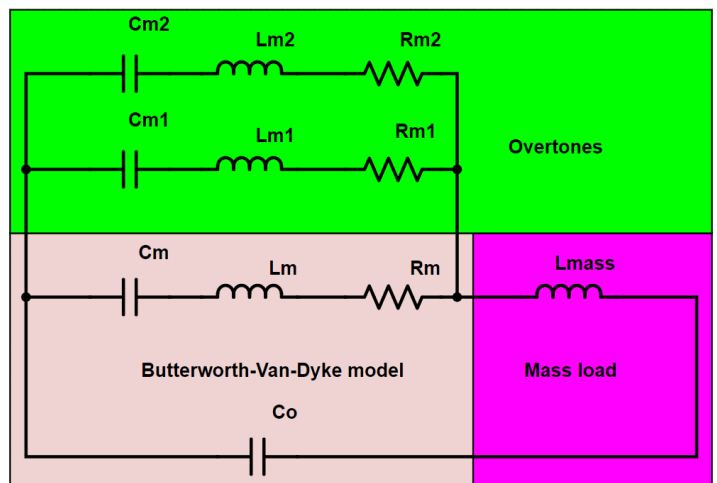
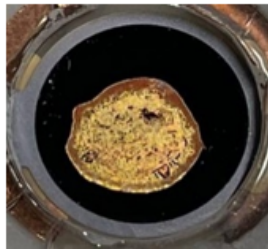

Figure 3.10 BVD model

3.5.2 QCM Sensor testing with the impedance analyser

Using the impedance analyser, the QCM piezo elements were tested with the chemical coating and exposed to the ripened bananas, which produce ethanal, for a total of 5 Minutes. The data has been recorded before the sensors have been coated and after. The data below shows the information on two types of sensors, where one pair has a resonant frequency at around 5Mhz and the other at 3Mhz with the picture of the coating on the sensor next to each dataset. It can be noticed that the influence of the coating is the least on the resonant frequency of both types of sensors. It is worth mentioning that the 5Mhz sensors have a titanium layer and the 3Mhz one gold layer. Both sensors have been coated with the same amount of chemical solution.

S-5.2 with a sweep range 4.998Mhz-5.010Mhz,				
S-5.1 coated with a sweep range 4.985Mhz-5.000Mhz,				
	Not coated	Coated	Difference	Deviation (%)
Resonant frequency (Hz)	5001297	4990769	10527.467	-0.21%
Impedance (Ω)	4980	890	4090	-82.13%
Phase (degrees)	12.23	-40.41	52.64	-430.42%



S-5.3 with a sweep range 4.998Mhz-5.010Mhz				
	Not coated	Coated	Difference	Deviation (%)
Resonant frequency (Hz)	5004716.455	5001537.008	3179.447	-0.06%
Impedance (Ω)	6340	2800	3540	-55.84%
Phase (degrees)	-58.94	-38	-20.94	-35.53%

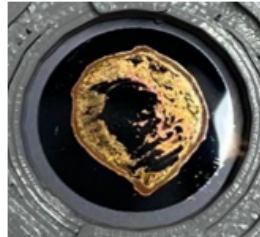

S-3.1 with a sweep range 2.95Mhz-3.050Mhz				
S-3.1 coated with a sweep range 3.010Mhz-3.020Mhz,				
	Not coated	Coated	Difference	Deviation (%)
Resonant frequency (Hz)	3017636.582	3016396.179	1240.403	-0.04%
Impedance (Ω)	1018	1334	-316	31.04%
Phase (degrees)	-79.17	-43.2	-35.97	-45.43%



S-3.2 with a sweep range 2.95Mhz-3.050Mhz				
	Not coated	Coated	Difference	Deviation (%)
Resonant frequency (Hz)	3017133.638	3016846.421	287.217	-0.01%
Impedance (Ω)	986	1064	-78	7.91%
Phase (degrees)	-43.92	-57.3	13.38	30.46%

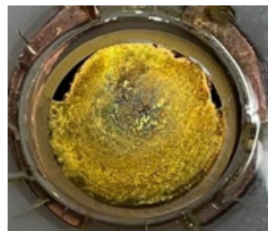
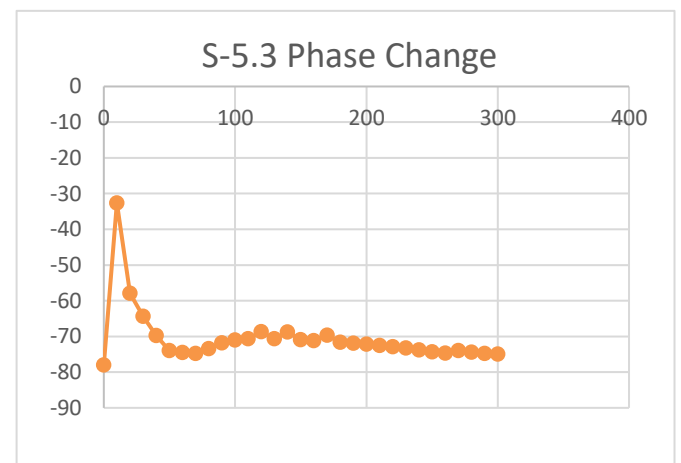
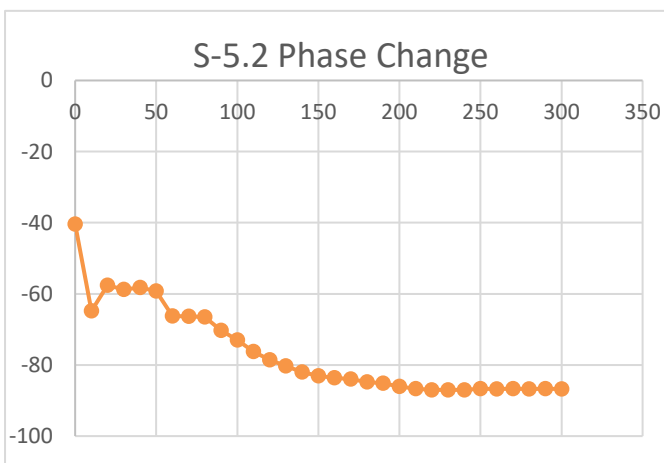
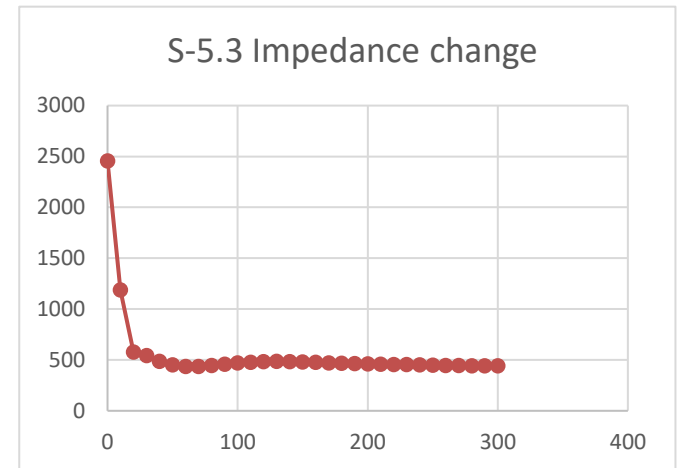
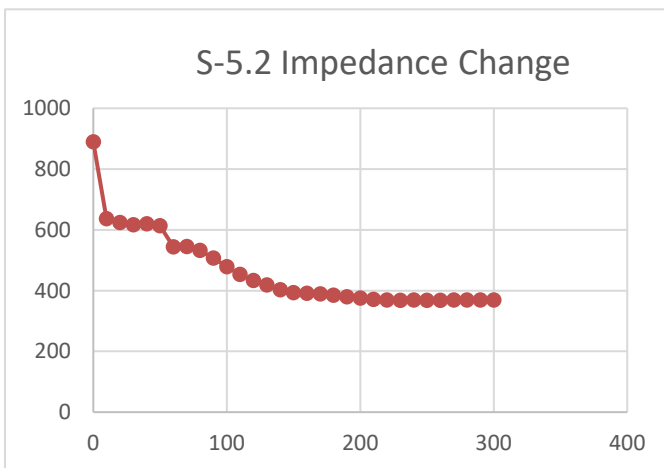
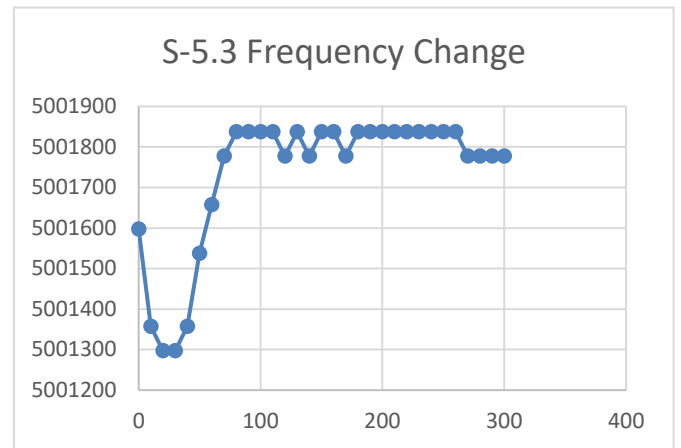
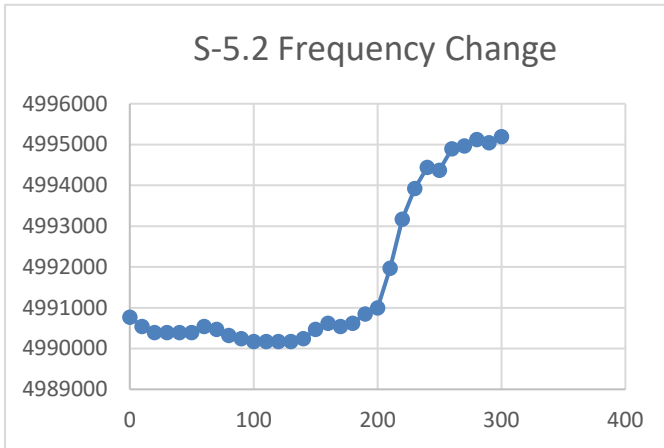
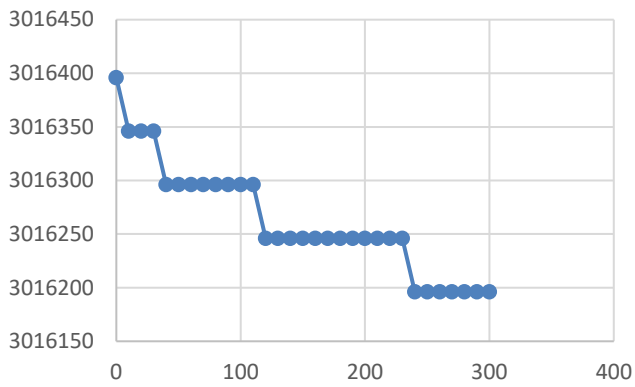

Table 3-1 Sensor data comparison

Here we can see how the resonant frequency, impedance, and phase change over the period of 5 minutes to the exposure to the ripe bananas. The data has been recorded every 10 seconds. The sensors exhibit similarities between the pairs, for example, 5Mhz sensors increase in the resonant frequency when exposed to ethanal, where the 3Mhz sensors show a clear decrease. The control tests have also been performed, where the clean sensors were exposed to the ripe bananas for the same amount of time, and no change in impedance, phase or resonant frequency has been recorded.



S-3.1 Frequency Change



S-3.2 Frequency Change

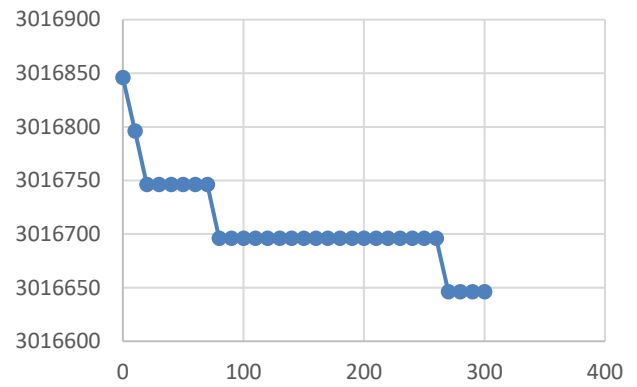

S-3.1 Impedance Change

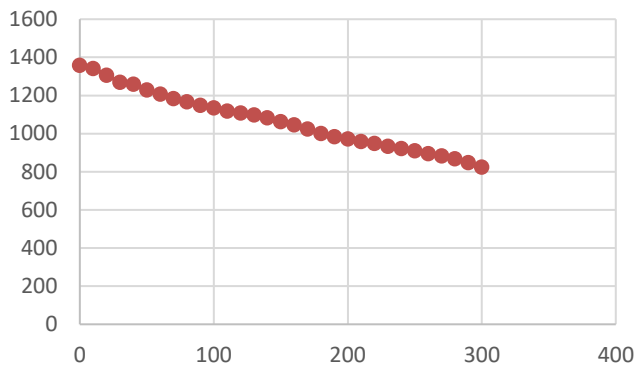

S-3.2 Impedance Change

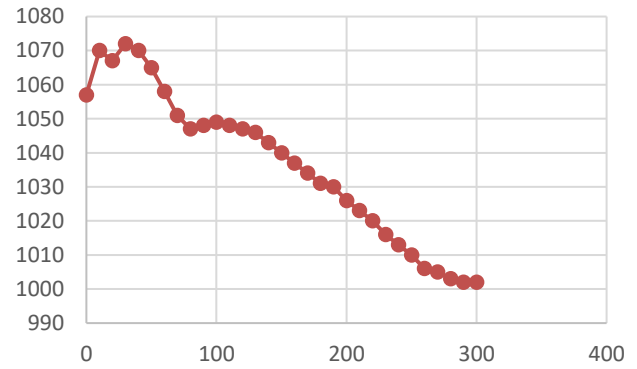

S-3.1 Phase Change

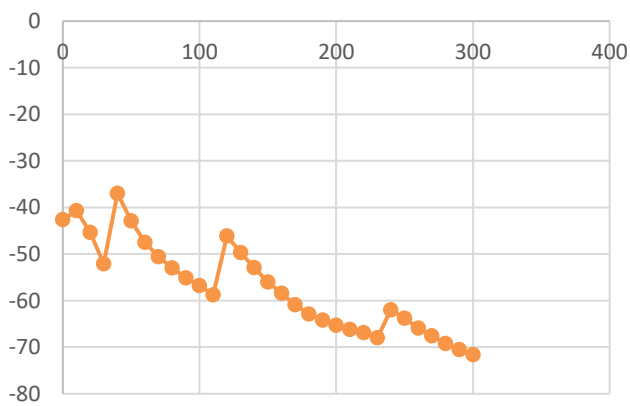

S-3.2 Phase Change

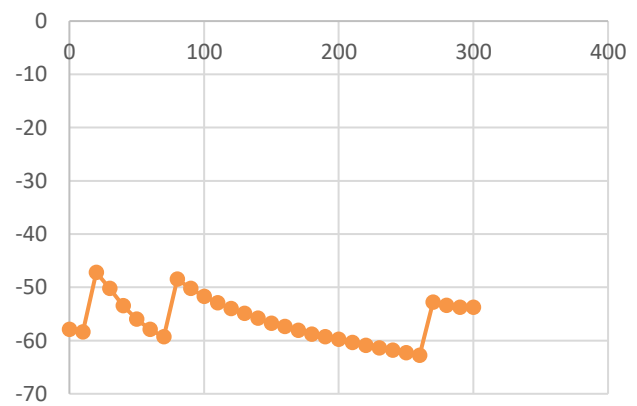

3.6 Components Selection

3.6.1 Membrane

Ethanal (C₂H₄O), a chemical compound that is usually found in various plants, ripe fruits, vegetables, and exhaled human breath⁷. A wide increase of Ethanal has been identified in Covid-19 positive patient's breath⁸. This is used as an indication to Covid-19 detection. To detect it, many different "e-nose" sensors can be used. Due to the project limitations, specified to use a piezoelectric membrane or diaphragm, a QCM (Quartz crystal microbalance) sensor has been chosen for the application. It has a wide range of research concerning the mass sensing of molecules, it tops other sensors in availability and stability.

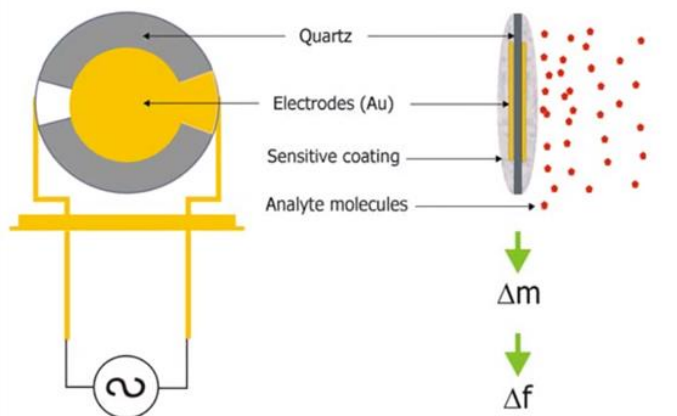

Figure 3.11 QCM piezo membrane⁹

QCM sensors use a quartz crystal for the piezoelectric material, which exhibits higher long-term stability and temperature resistance compared to ceramic piezoelectric materials like Lead zirconate titanate (PZT), barium titanate (BT), and strontium titanate (ST)¹⁰. This means that it is more suitable for high precision sensing.

⁷ Yong Hoon Kim, Yun Jae Yang, Jin Se Kim, Dong Soo Choi, Seok Ho Park, So Yeon Jin, Jung Su Park, Non-destructive monitoring of apple ripeness using an aldehyde sensitive colorimetric sensor, Food Chemistry, Volume 267, 2018, Pages 149-156, ISSN 0308-8146,

⁸ Dorota M Ruszkiewicz, Daniel Sanders, Rachel O'Brien, Frederik Hempel, Matthew J Reed, Ansgar C Riepe, Kenneth Bailie, Emma Brodrick, Kareen Darnley, Richard Ellerkmann, Oliver Mueller, Angelika Skarysz, Michael Truss, Thomas Wortelmann, Simeon Yordanov, C.L.Paul Thomas, Bernhard Schaaf, Michael Eddleston, "Diagnosis of COVID-19 by analysis of breath with gas chromatography-ion mobility spectrometry - a feasibility study" EClinicalMedicine, Volumes 29-30, 2020, 100609, ISSN 2589-5370,

⁹ <https://www.creative-biolabs.com/drug-discovery/therapeutics/quartz-crystal-microbalance-qcm.htm>

¹⁰ Bansal, Dipali. (2012). Potential of Piezoelectric Sensors in Bio-signal Acquisition. Sensors and Transducers. 136. 147-157.

3.6.2 Waveform Generator

For this project, the waveform generator AD5932 has been used to generate the frequency sweep.

This particular waveform generator has been selected since it outputs each frequency in the range of interest for a defined length of time and then steps to the next frequency in the scan range. The length of time the device outputs a particular frequency is preprogrammed, and the device increments the frequency automatically. The frequency scan profile is initiated, started, and executed by toggling the CTRL pin. The most appealing features were the frequency range up to 25Mhz, single pin control, power supply range from 2.3V to 5.5V, Low power solution consuming only 6.7 mA¹¹.

Few other waveform generators were considered:

MAX038 – Out of production.

AD9833- No automatic frequency sweep set up.

AD5930- Lots of unnecessary features.

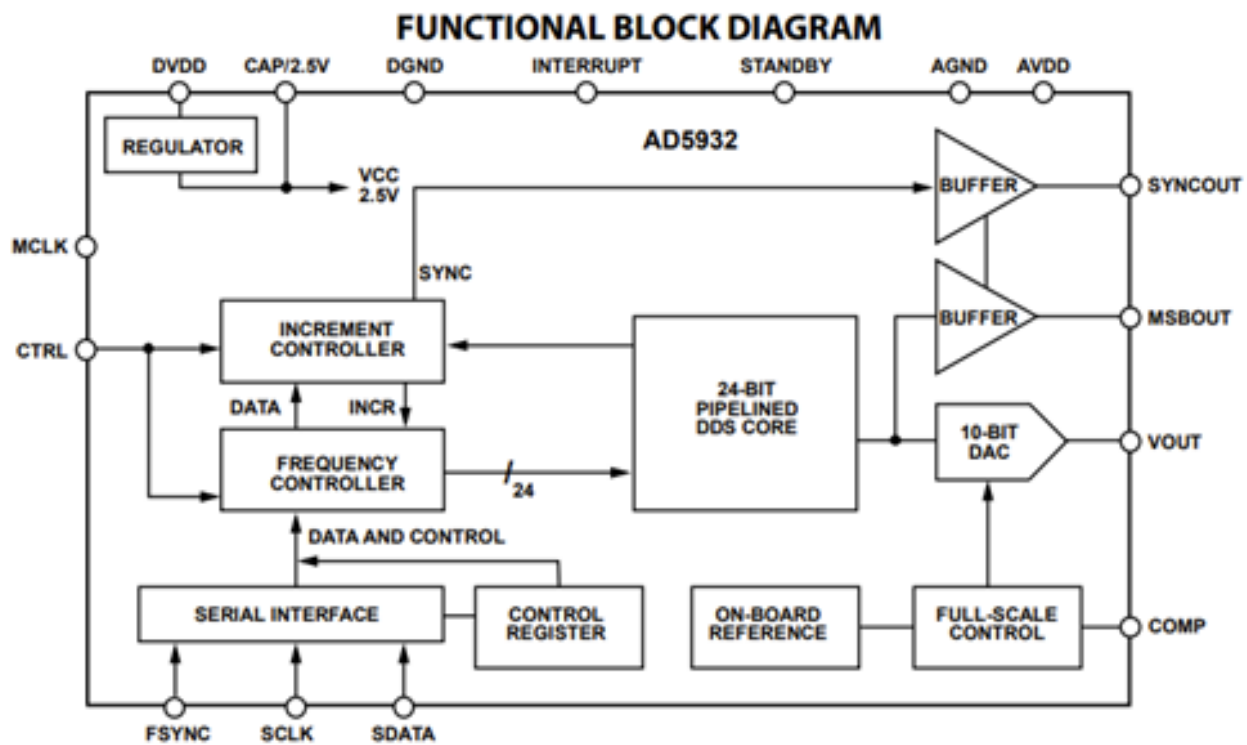

Figure 3.12 Functional Block Diagram

¹¹ Analog Devices "Programmable Frequency Scan Waveform Generator" Rev C. 4/2017

3.6.3 Teensy vs Arduino nano

	Teensy 4.1	Arduino Nano
Processor	ARM Cortex-M7	ATmega328
Processor speed	600MHz	16 MHz
Memory	7936K Flash memory 1024K RAM 4K EEPROM QSPI memory expansion locations for 2 extra RAM or Flash chips SD Card extension	2 KB SRAM 32 KB flash memory 2 KB used by bootloader 1 KB EEPROM
Pins	55 digital input/output pins, <ul style="list-style-type: none"> • 35 PWM output pins • 18 analogue input pins • Pin Change Interrupts 	8 Analog I/O Pins 22 Digital I/O Pins 6 PWM Output
Communication	8x serial ports 3x SPI ports 3x I2C ports 3x CAN bus	SPI I2C
Extra	Float point math unit, 64 & 32 bits	/
ADC speed	~1MHz	~ 9.6kHz
ADC	12-bit resolution	10-bit resolution
Supply	5v	5-12V
Power out pin	5v 3.3V	5v 0-5V

Table 3-2 Comparing Teensy 4.1 with the Arduino Nano

In this project, accuracy and speed are of high importance. The microcontroller needed to have a high sampling speed and processing power.

Two microcontrollers were considered. The teensy 4.1 and the Arduino nano.

The Arduino Nano is a very common and robust microcontroller but could not provide the requirements which were needed to be the main processing unit. That is why teensy 4.1 was chosen. With the teensy high ADC speed and big flash memory, fast sampling was possible.

For fast execution of code or math, the teensy has a 600MHz processor and an integrated floating-point math unit. Floating-point math units are dedicated architectures to typically execute addition, subtraction, multiplication, division, and square root.

3.7 Tasks

3.7.1 Programming, data processing and actuation (Title)

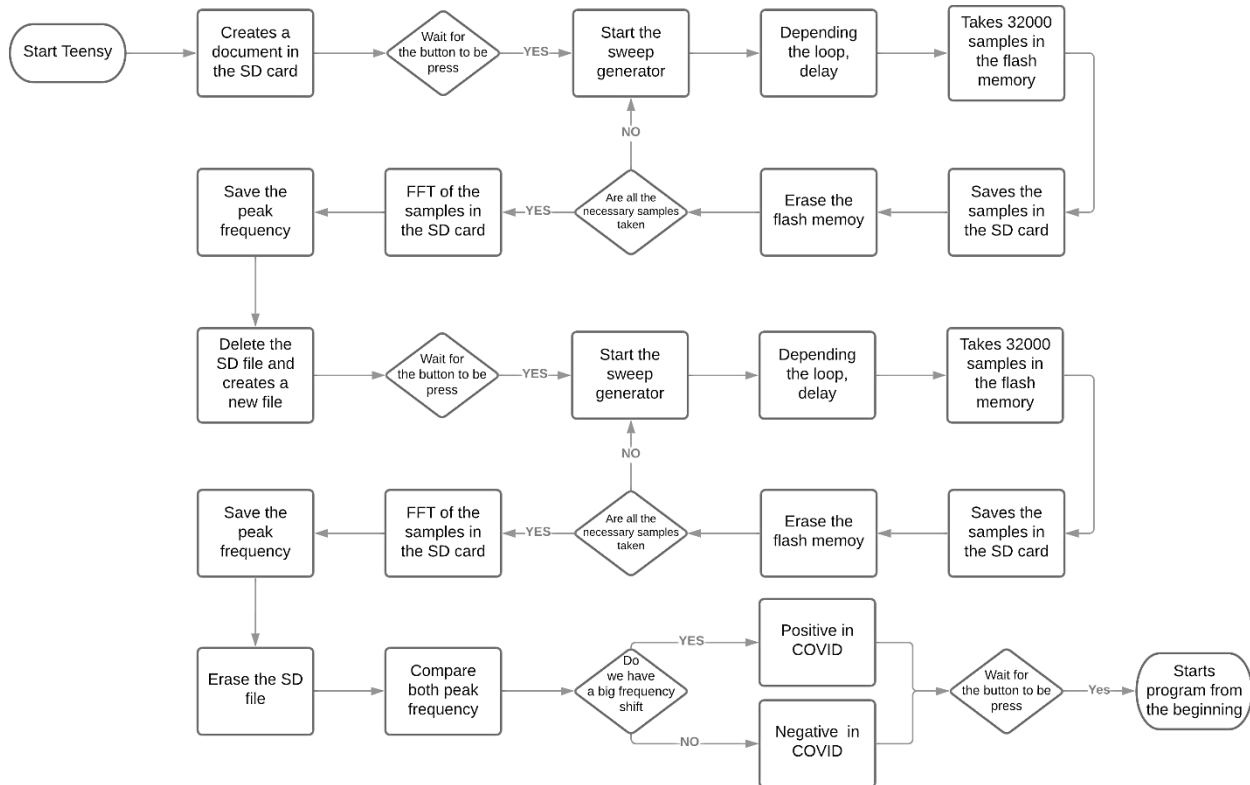

Figure 3.13 Programming Flow Chart

Description/Requirements

As we can see, the Figure 3.13 is a Flow Chart from the full code which can be seen in the Appendix 8.8 (“Teensy code”). At the time of making the code, the limitations of the Microcontroller, Teensy 4.1, as well as the number of different tests to be carried out, have been considered.

To be able to read the ADC, the data must be stored in the Flash memory which is limited to a max of 32000 samples but, normally we need to take more. The samples are saved in the SD card and later start the sweep again and take 3200 samples.

Method

Sweep Generator

To carry out the programming of the chip that performs the sweep, the Arduino has had to be used due to 3.3V output voltage of the Teensy, therefore we have the Teensy that triggers the sweep, but it is the Arduino that programs it. There are four parameters which result in the range and the total time, which are the start frequency, the increment frequency, number of increments and the interval duration.

ADC Read

Theoretically Teensy takes the samples at a frequency of 1MHz, that means that every 1us and from the analogue input 0 that is the faster of all the analogue inputs. Therefore, we decided to check if this was true, and at what frequency we were actually taking the samples, so that we could make the FFT accurate.

The frequency generator was set to create a ramp signal at a frequency of 250Hz so a period of 4000us, if we are taking 16000 samples and a sample every microsecond, we should see exact four ramps although as we can see in Figure there are more than four ramps but from these tests we can deduce that the sampling frequency is constant.

$$f_{\text{sampling}} = \frac{f_{\text{theoretically}} * N_{\text{ramps}}}{N_{\text{totalRamps}}} = \frac{1\text{MHz} * 4 \text{ ramps}}{4.415 \text{ ramps}} = 0.906\text{MHz}$$

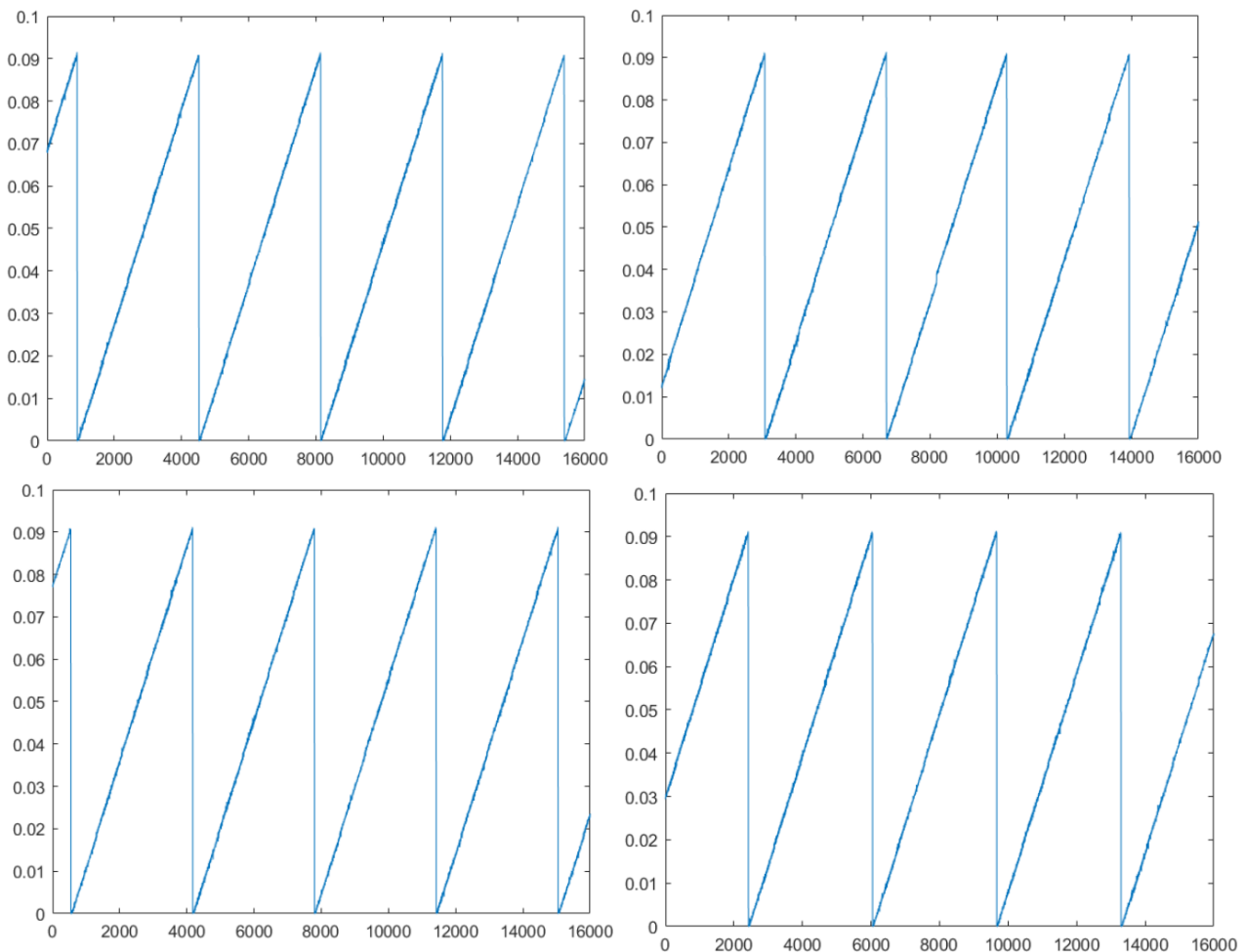

Figure 3.14 250Hz ramps

SD card

This functionality gives us access to create txt and csv files on the SD card, although to be able to read the file it has to be txt. You can create as many files as you want with as much data as necessary, therefore for future studies the information could be saved or create a file for each person.

In our final program for the proof of concept, the file is created and destroyed each time since we did not think it necessary to create multiple files.

FFT

The discrete Fourier Transform is relatively simple functions but that requires a lot of computational power especially when the quantity of samples is incremented since it works by loops.

When the FFT is performed in MATLAB we have all the representation along the frequency but in the Teensy program we can obtain the peaks directly, which is what we are interested in for knowing the change in frequency.

Result

Doing the whole process from the creation of the file to the deletion takes between 5 and 15 seconds, depending on the number of samples. To carry out the whole process, blowing and pressing the button would be around a minute being a very good result.

This method is not fully functional since our sensors sweep at a frequency that the ADC cannot sample, but once the peak detection is implemented it could be done very easily

Conclusion

All possible objectives have been met although further implementation is needed. All the parts mentioned above work individually and together, making the program as versatile as possible and giving the option of many different possibilities.

3.7.2 Indicator Circuit

Description/Requirements

The device is equipped with two indicator systems. One for the battery charge, the other for the operation. The operation indicator is supposed to be controlled digitally using the microprocessor and indicate the testing progress and its result. The battery indicator circuit would be an analogue built determining three levels of battery charge: 20%, 60% and 90%.

Method

The operation indicator board consists of 3LEDs. Each of them is connected to common ground and a resistor leading to a PIN. The principle is simple, sending 1 on the pin enables the LED.

The battery indicator circuit was built basing on a 12V battery circuit design. The resistance levels were calculated and adjusted accordingly to fit the 6V power supply, which would use 4 AA 1.5V batteries. The circuit consists of a quad comparator opamp (LM324), which allows to use 4 comparators in a single chip. Three of them are used, corresponding to each LED. The resistors were adjusted by testing for the LEDs to indicate a total power drop to 5.6V (90%), 4.9V(60%) and 4.2V(20%). The battery capacity values were taken from a standard Duracell AA batteries datasheet (Appendix Battery Performance Graph). The circuit schematic can be seen bellow.



Figure 3.15 Operation Indicator

We can divide the circuit in two parts for control the battery level. Connected to the inverting input of the op-amp, we have a voltage divider. The D1 is a reference Zener Diode which is rated to 3.3V so it will regulate the output to 3.3v across it. There are three resistances connected in parallel so theoretically the voltage should be distributed as in a series circuit.



Figure 3.16 Battery Indicator

R6 should be 600Ω and R5 5kΩ unlike the values that can be observed above. The reason for this difference is the Zener diode, which allows the current to pass at a much lower voltage, so we decided to test a circuit by changing only the diodes to observe at what voltage the LEDs turn on.

Zener diode	Diode 1	Diode 2	Diode 3	Diode 4	Diode 5	Diode 6
Voltage 1 (V)	4.23	4.48	4.21	4.51	4.36	4.43
Voltage 2 (V)	4.91	5.18	4.87	5.20	5.04	5.13
Voltage 3 (V)	5.6	5.86	5.54	5.90	5.70	5.83

Table 3-3 Zener diode comparison

In conclusion, the Zener diodes are a problem for the circuit and if you wanted to mass produce it would be a problem for being consistent, unless you found another more reliable diode or another circuit it would be much better to do it digitally.

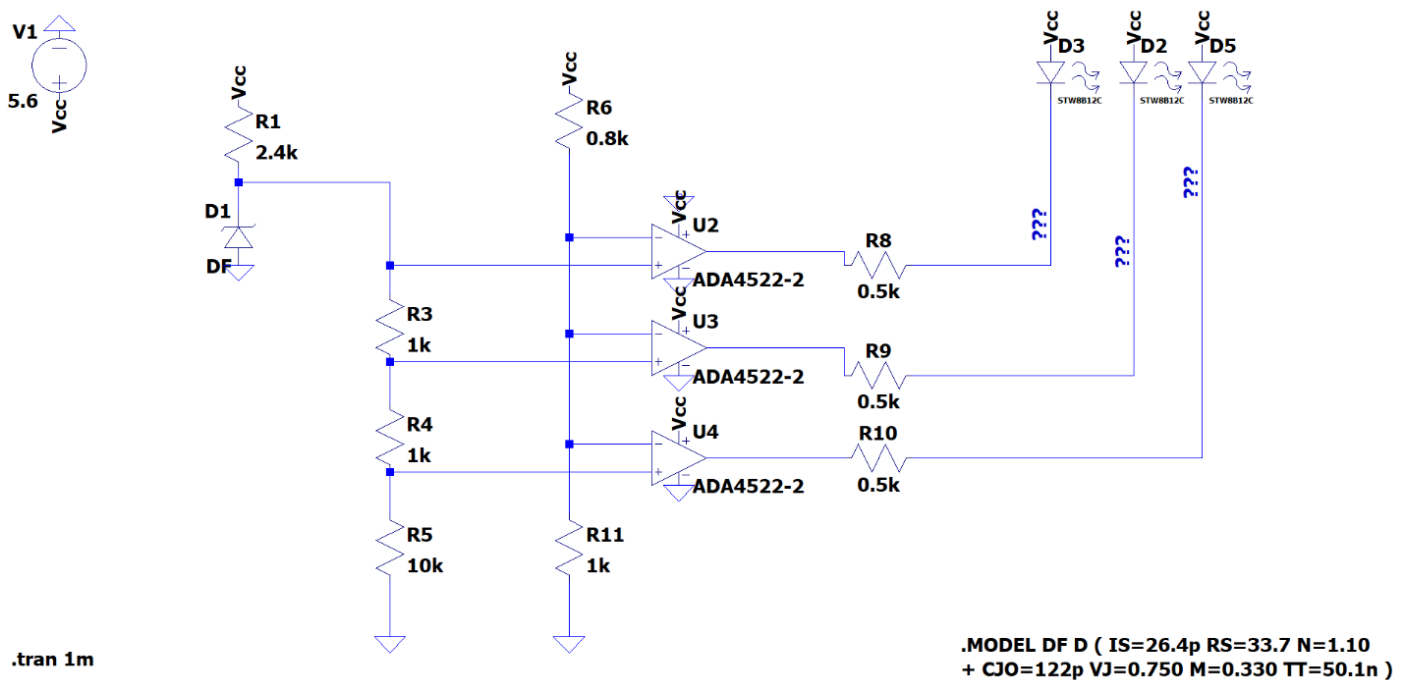

Figure 3.17 Battery Charge Circuit Schematic

4 Chemical design

4.1 Objective:

As QCM sensor technologies are based on mass different detection, a coating able to bound with ethanal needed to be identified. The coating needs to be deposited on QCM sensor surface Ti/Au Supported by food industry research¹² paper on the development of an ethanal sensitive colorimetric sensor used to assess the ripeness of fruits (indeed ethanal is also detected in gas form during the rotting process of fruits) few recipes were identified.

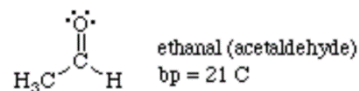

Figure 4.1 Ethanal molecule

Available recipes are based on a process that can be vulgarised as an organic redox reaction happening between the identified aldehydes (ethanal; C₂H₄O) and Methyl Red (C₁₅H₁₅N₃O₂). As described in figure 4-2 Methyl red indicate a colour change when increasing its hydrogens ions + concentration hence its acidity.

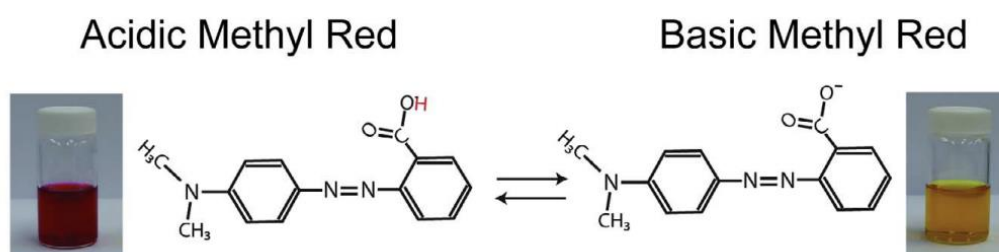

Figure 4.2 Methyl red representation

The chemical reaction involving of aldehydes in contact with methyl red can be found in annexe 8.6.

Therefore, the tested solutions were based on a combination of:

- Methyl red (C₁₅H₁₅N₃O₂). and methyl red sodium (C₁₅H₁₄N₃NaO₂). salt for ethanal detection and colorimetric change.
- Hydroxide sodium salt (NaOH) used to provide the necessary hydroxide anion in the chemical reaction (annexe).
- Water and methanol (MeOH) solutions as a solvent and Ph adjuster.

Special precaution needs to be taken as the used substance are classified as harmful to health and environment. A chemical risk assessment (annexe 8.7) was performed to ensure a safe handling of the solutions.

4.2 Methods

As presented in results three different recipes were tested following the same methods.

To prepare the recipes the following procedure was used:

- Mixing for 2 hours at room temperature of the liquid solution containing water and methanol with methyl red solid powder and methyl red sodium salt crystal.
- After 2 hours addition of NaOH pellet and stirring for another 2 hours.

From initial development and with the idea to enable quantitative detection a constant volume was kept on each sensor; this volume was determined to cover enough of the sensor without overlapping the golden coating insuring all the dried volume is within the detection surface. After some testing iterations¹, this

¹² KIM, Yong Hoon, YANG, Yun Jae, KIM, Jin Se, *et al.* Non-destructive monitoring of apple ripeness using an aldehyde sensitive colorimetric sensor. *Food chemistry*, 2018, vol. 267, p. 149-156.

volume was determined to be 30ul for the 14mm sensors and 40 ul for the 25.4 mm one. Every deposition were performed using an optical angle measurement devices allowing flow control and micrometric volume deposition. The deposition flow was set to be half the volume to deposit (hence 15 ul/s and 20 ul/s), this flow rate offers a nice distribution of the solutions on the area to coat without leading to over accumulation.

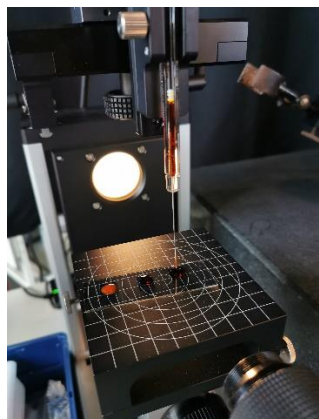

Figure 4.3 Deposition set up.

Further development using advance equipment could determine the dry thickness of the volume hence tuning the deposition volume as well as enabling quantification of detected molecule. Each recipe was tested on a SiO₂ dummy to test the dryness as well as the texture of the coating. Meanwhile each solution was also deposited on cotton pad to test exposition to banana and colour change.

Deposition set up using grind to align sensor/dummy and micrometric volume dispensation can be observed in *figure 4-3*. Through the development a simple cleaning method using acetone ultrasonic bath for 1 h and then wiping using non scratching fibbers and ethanol was used between the different coating. All observation were performed on a digital microscope from the brand Leica coupled with a numerical camera.

4.3 Results

<p>Recipe 1.</p> <p>Methyl red: 0.4g Methyl red salt: 0.35g NaOH: 2.5g Water:10 ml Methanol: 10ml</p>	<p>Inhomogeneity of coating and recrystallization.</p> 
<p>Recipe 2.</p> <p>Methyl red: 0.4g Methyl red salt: 0.35g NaOH: 2.5g Water:10 ml Methanol: 5ml Glycerol:5ml</p>	<p>Viscous surface and dried boundaries.</p> 
<p>Recipe 3.</p> <p>Methyl red: 0.12g Methyl red salt: 0.13g NaOH: 0.1g Water:250 ml Methanol: 250ml</p>	<p>Final homogenous coating.</p> 

Table 4-1 Recipes results

The first provided recipes offered a successful colour change to ethanal exposition but a poor bounding to the deposited surface due to the high concentration of methyl red. Indeed, after drying methyl red presented a high recrystallization leading to an inhomogeneous brittle structure. To solve this issue of recrystallization, glycerol was included in the recipes. However, the high viscosity of the new solution shown a constant “wet” state of the coating leading to leak when manipulated. The final recipes was determined adjusting the molar concentration of methyl red (1.2 mM), methyl red salt (1.2 mM) and NaOH (8mM) as presented in the research paper. Here the solvent volume needed to be increased to achieve the right concentration as the available equipment limit the weighting of the needed substance to 10mg.

For every coating tested the structural change on the Ti/AU-SiO₂ sensor substrate (when present) happen within few seconds. The observed structure change happens in an irreversible process as the structure kept its crystalized aspect even after weeks without exposition. possible). Due to a mistake from the QCM crystal supplier, the last bench of sensors was delivered without the gold coating once offering a Ti/SO₂ surface. Those sensors presented a higher hydrophobic surface hence a reduced surface coverage per deposit volume as well as a longer drying time.

	Non exposed coating	Exposed coating (10s to rotten bananas)
Recipe 1 Ti/AU-SiO ₂ sensor		
Recipe 3 Ti/AU-SiO ₂ sensor		
Recipe 3 Ti-SiO ₂ sensor		

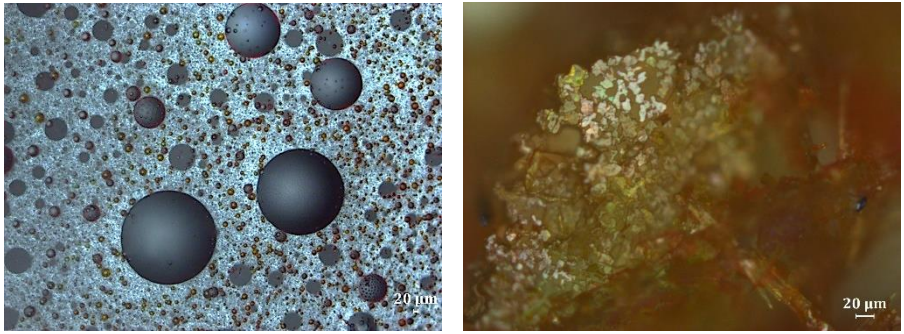
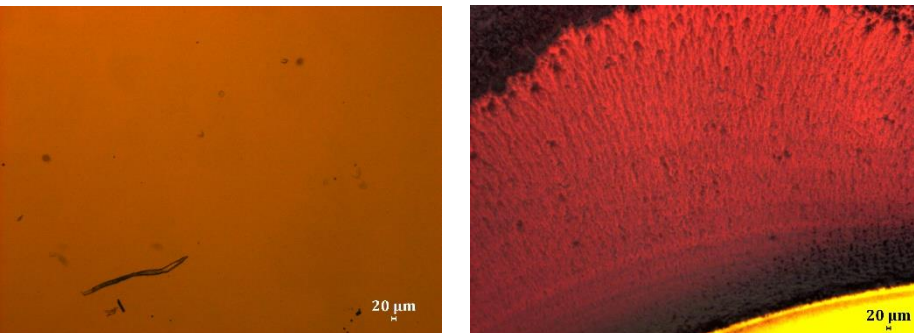
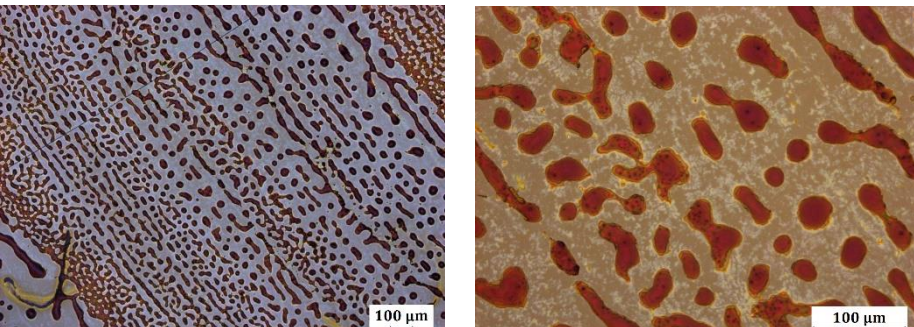
Table 4-2 Comparison of exposed and non-exposed coating

4.4 Discussion

As a proof of concept, the final coating was deposited on a cotton pad and sent to confirmed positive COVID-19 patient. As shown in figure 4.4, the coating offered the expected colour change when in contact with patient breath indicating a clear detection of ethanal.

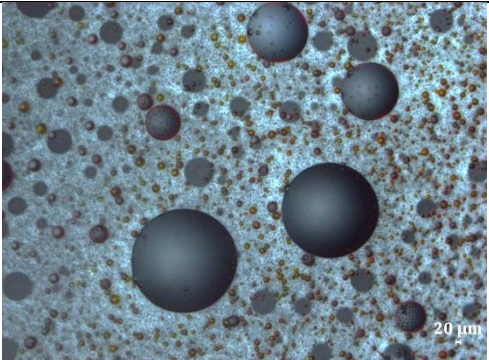
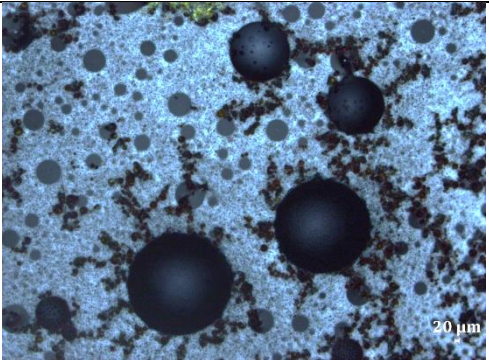
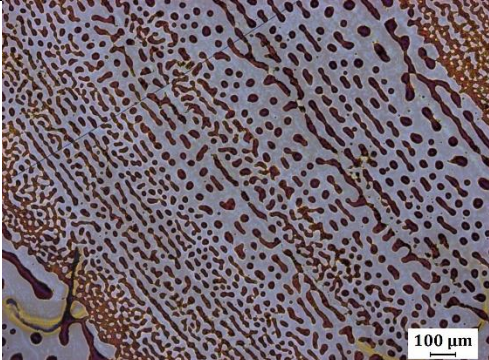
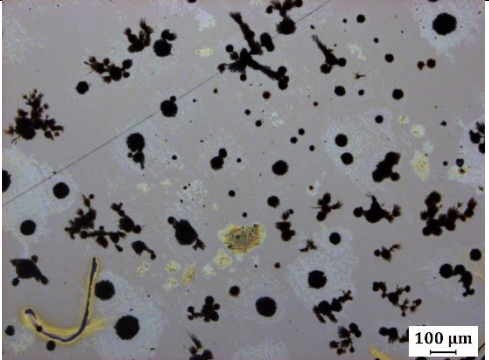
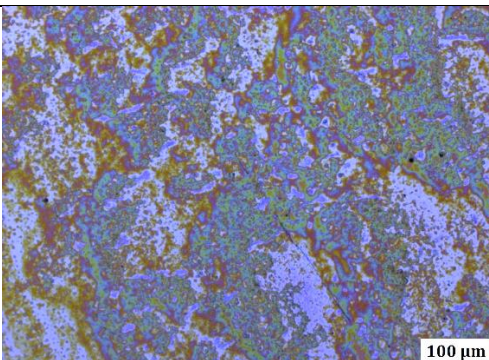
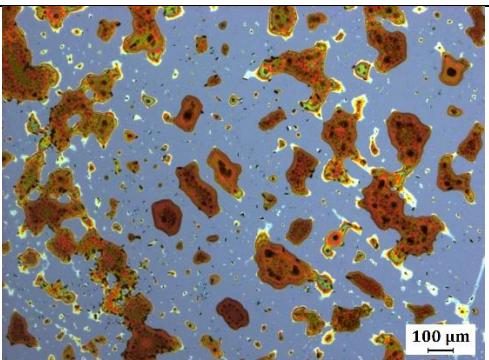

On the left:
exposed to COVID-19 patient
breath.

On the right:
non-exposed dummies.

Figure 4.4 Coating tested on COVID-19 patient

Even with an irreversible observed surface change, the sensor and the coating seem to be reusable and still allow ethanal weighting after prior exposition. Further characterization using mass spectrometry as an example could help assessing the repeatability of the sensor. Indeed, optical methods are here limiting in the observation of molecular bond, further methods using mass spectrometry as an example could indicate the efficiency of the coating after multiple use.

The final coating still offer room for improvement as some issues on the homogeneity when deposited on big surface are still observed. Some investigations and adjustment of the recipe using surface energy and contact surface angle could improve the final deposited area.

5 Mechanical Design

5.1 Design Overview

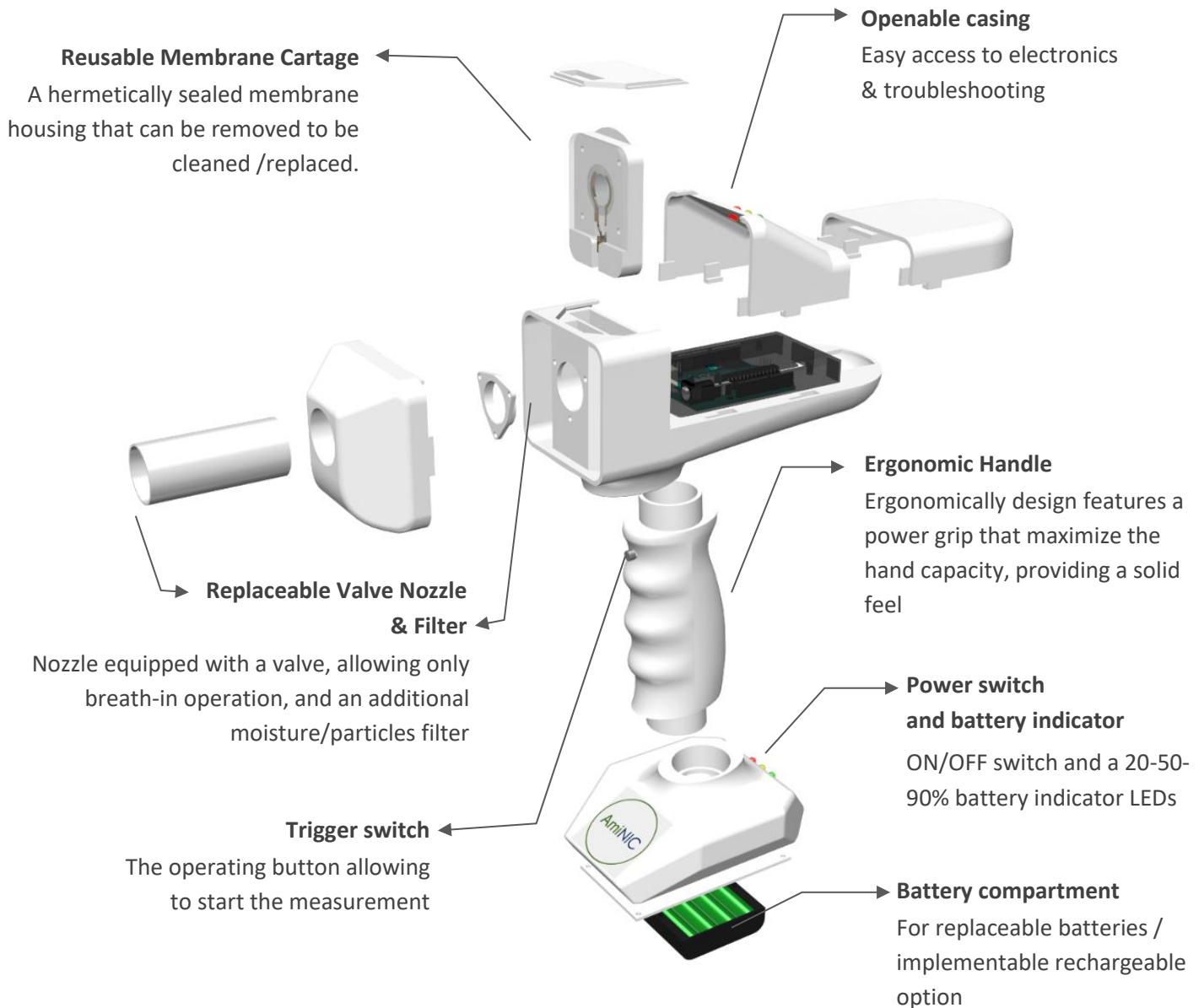

Figure 5.1 Design Exploded View

5.2 Introduction

The final product as shown above (figure 5.1) is the result of great teamwork, numerous group discussions, and thoughtful considerations. At first, the design choices were thoroughly debated between the mechanical group members until a definitive consensus was reached. Afterward, the chosen design has been presented to the rest of the team for further evaluation. Daily and weekly team meetings resulted in numerous design changes during the designated project time, with each part being alternated numerous times, to better suit the needs of the other groups and most importantly the project's goal. All parts were manufactured and

assembled during the project period, except for the cartridges, which needed to be constantly tested, and as such, every variation got manufactured.

Before the beginning of the design process, the mechanical group also set some ground rules and guidelines that had to be kept in mind throughout the whole project duration:

- The casing design must be based upon familiar-looking tools, so that it is easy to understand and intuitive. The aim is to reduce any potential errors and the time that the user has to spend familiarizing himself with the device. After providing the user with a brief introduction, the user should be able to quickly understand how to operate and care for the device.
- The design should not exceed the total weight of 0.5kg and be balanced to minimize the strain on the user for enduring use cases. Ensuring that all components and features fit within the casing and can be handled by the average person in one hand.
- The compartment containing the sensor should be easily removable but be still able to seal the sensor from the rest of the device.
- The design should allow for easy access to and replacement of the filters and batteries and the removal of the cover over the electronics.
- Following the basic principles of the medical sector, e.g.: no sharp corners, no exposed screws, ...

Additionally, as the design that the group is working on is a prototype the casing should not only be able to house its components but also allow for access if later modifications and/or servicing the device is necessary.

5.3 Testing Setup

The testing setup has been designed and built at the very beginning of the project as a means to test the chemical solution in an environment that would allow for the best accumulation and further distribution of ethanal particles present in the air. This was done before any work has started, as some of its features could be considered ineffective or even detrimental.

It consists of two chambers both made of acrylic that was cut to shape at the laser cutter. The first chamber acts as a collector for ethanal, and since the groups' way of gathering ethanal was by placing decomposing bananas into an enclosed space which would then diffuse ethanal into the air, the main constrain that had to be kept in mind while designing was size. The chamber was made to be 13.6 x 20 cm x 14 cm which could then hold up to 5 average sized bananas (18 cm average length and 15.5 cm average circumference). A circular extrusion with a radius of 5 cm has been added to the front panel of the chamber together with 4 holes with 2 mm radius to accommodate a USB powered ventilator fan which would be used to transfer the ethanal filled air to the second chamber. The second chamber's purpose was to keep the cartridge and the sensor in place and centered to the fan exhaust of the first chamber. This was achieved by cutting 12 holes with 5 mm radius into which the cartridge would slot, furthermore only two holes would be occupied at the same time allowing the leftover ones to function as exhausts. The holes were made in a circular pattern allowing the team to position the cartridge at different angles to test whether this would have any impact on the result. This however was not tested due to the inefficiency of this testing method.

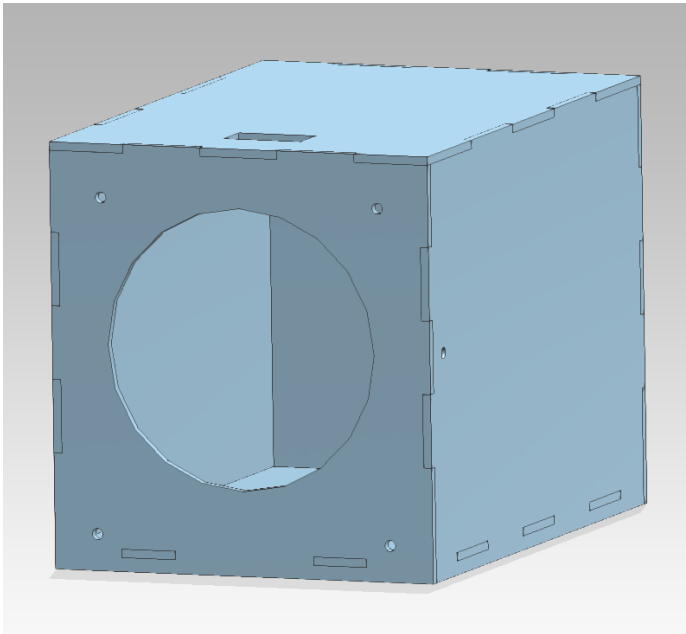

Figure 5.3 First Chamber

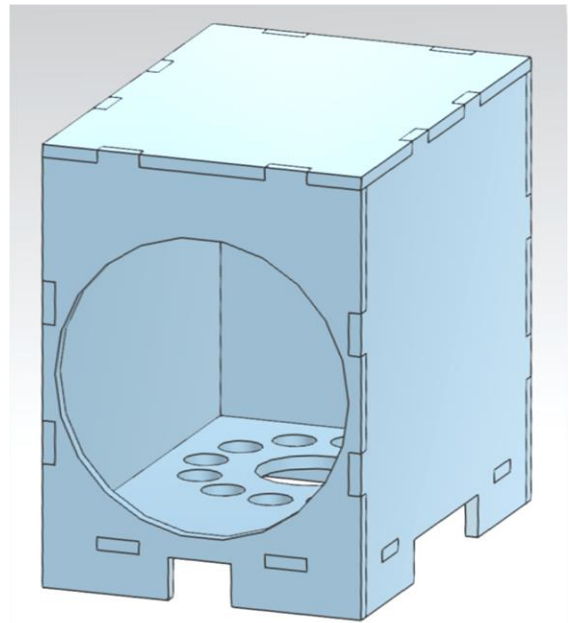

Figure 5.2 Second Chamber

Testing showed that gathering ethanal in the first chamber and then diffusing it via the fan into the second chamber onto the cartridge with the sensor and solution proved less efficient and more time-consuming than just leaving the solution in an enclosed space containing decomposing bananas.

5.4 Technical Research

5.4.1 Ergonomic design

Since the project aims to make the product mobile the authors decided that making the design to be ergonomic would be a requirement. Subsequently, to fulfil this requirement the authors had researched and studied how to make an ergonomic design. To do this the group aimed to design the handle that would allow the user to maintain a neutral wrist posture while also following a set of ergonomic design guidelines.

Ergonomic guidelines¹³:

Guidelines - Summary		
Description	Guideline	Reason
Tool shape	Slightly contoured	Easy grip
Direction of force is in-line with forearm and wrist (typically horizontal)	Bent handle	Minimal wrist deviation
Direction of force is perpendicular to forearm and wrist (typically vertical)	Straight handle	Minimal wrist deviation
Separation distance between handles (for crushing, gripping or clipping tools such as pliers or tongs)	65-90 mm (separation distance)	Maximum grip strength
Handle length	>100 mm	Keep contact out of palm
Handle diameter (power grip)	30-50 mm	Greater force and stability
Handle diameter (precision task)	8-16 mm	Greater control
Material and texture of handles	Non-slip non-conductive materials	For comfort and reduces effort required to use tool

¹³ <https://www.ccohs.ca/oshanswers/ergonomics/handtools/tool design.html>

Neutral wrist posture¹⁴:

A neutral posture is achieved when the muscles are at their resting length and the joint is naturally aligned. For most joints, the neutral posture is associated with the midrange of motion for that joint. When a joint is not in its neutral posture, its muscles and tendons are either contracted or elongated. Joints in neutral postures have maximum control and force production [Basmajian and De Luca 1985; Chaffin et al. 2006]. Neutral postures also minimize the stress applied to muscles, tendons, nerves, and bones. A posture is considered —awkward|| when it moves away from the neutral posture toward the extremes in a range of motion.

5.4.2 Medical criteria for the device

Since the project is intended to be used as a medical device the group had to make considerations to make sure that the final product will be compliant with the relevant standards. For this purpose, the group has decided to follow the regulations for Devices with a diagnostic or measuring function found in the REGULATION (EU) 2017/745 OF THE EUROPEAN PARLIAMENT AND OF THE COUNCIL of 5 April 2017 on medical devices, amending Directive 2001/83/EC, Regulation (EC) No 178/2002 and Regulation (EC) No 1223/2009 and repealing Council Directives 90/385/EEC and 93/42/EEC document:

15. Devices with a diagnostic or measuring function

15.1. Diagnostic devices and devices with a measuring function, shall be designed and manufactured in such a way as to provide sufficient accuracy, precision, and stability for their intended purpose, based on appropriate scientific and technical methods. The limits of accuracy shall be indicated by the manufacturer.

15.2. The measurements made by devices with a measuring function shall be expressed in legal units conforming to the provisions of Council Directive 80/181/EEC (1).¹⁵

This meant that the group had no direct limitations regarding the design. However, additional requirements regarding design and manufacture have been chosen:

10.5. Devices shall be designed and manufactured in such a way as to reduce as far as possible the risks posed by the unintentional ingress of substances into the device taking into account the device and the nature of the environment in which it is intended to be used.

11.1. Devices and their manufacturing processes shall be designed in such a way as to eliminate or to reduce as far as possible the risk of infection to patients, users, and, where applicable, other persons. The design shall:

- (a) reduce as far as possible and appropriate the risks from unintended cuts and pricks, such as needle stick injuries,
- (b) allow easy and safe handling,
- (c) reduce as far as possible any microbial leakage from the device and/or microbial exposure during use, and

¹⁴ <https://www.cdc.gov/niosh/mining/UserFiles/works/pdfs/2011-191.pdf> – page 4

¹⁵ <https://eur-lex.europa.eu/legal-content/EN/TXT/PDF/?uri=CELEX:32017R0745> – page 99

(d) prevent microbial contamination of the device or its content such as specimens or fluids.

11.2. Where necessary devices shall be designed to facilitate their safe cleaning, disinfection, and/or re-sterilization.¹⁶

Nozzles are the only part of the device that comes in contact with the person being examined, as such the group wanted to make sure to use a medical grade appliance. For this purpose, a medically certified Spirometer Mouthpiece 99.837.14 developed and manufactured by LESSA® was chosen. These nozzles were primarily chosen as they are affordable (0.054 € per piece) and biodegradable since they are made from paper.

5.4.3 Materials

While researching materials that could be used for the project the authors decided on the following:

Casing Material - Casing Material - for the design it was decided to use 3D printed filament. Besides its relatively cheap cost of around 170dkk/kg it is capable of rapidly building complex structures as designed with quality varying based on the Printer settings. Prusa printers were available in the 3D printing lab by request. They had a tolerance of up to 0.2mm during prints which was determined as sufficient for the structural components of the Prototype.

Cartridge Materials - for the cartridge materials it was defined for them to have minimal tolerances as well as be nonconductive. SLA printing resin was an available option in the 3D printing lab by request. When SLA printing the Cartridges, the tolerances of the printer were up to 0.1mm which was determined acceptable for testing prototype cartridges. Laser-cut acrylic plates were used as well since it allowed to fasten the Membranes in place on the Cartridge. Due to it being flexible it did not damage the Membranes and allowed for clear visual inspection of the Membranes. Although sufficient tests in the early stages of the project were made, the authors decided to switch to water cut Lexan pieces. This was due to the coating reacting with the acrylic leading to cracks. Lexan behaves similar to acrylic without the downside of reacting with the coating applied to the membrane. Additionally, it is more impact resistant than Acrylic.

Filters - for the filters it was chosen to use parts of surgical masks. As they are capable of filtering out debris and other unwanted airborne particles to an extent. Allowing for the protection of the membrane in the design.

Glue - to permanently fasten some parts of our casing design to each other it was chosen to use super glue. Due to its availability, possible medical usage for small cuts, as well as not releasing toxic chemical fumes like other resins during application was chosen as the glue of choice for assembly.

Bolts and Nuts - in the case where it was not possible to use glue as a fastener, stainless steel bolts and nuts were chosen instead. Due to their non corrosive properties, which will negate most injuries or infections due to the material degradation, it deemed them sufficient for our design.

5.5 Individual parts

5.5.1 Main head part

When describing the main head part, the upper part that the ergonomic grip is directly attached to is what is being described. It serves as a base for the microprocessor as well as the Cartridge slot itself.

¹⁶ <https://eur-lex.europa.eu/legal-content/EN/TXT/PDF/?uri=CELEX:32017R0745> – page 97

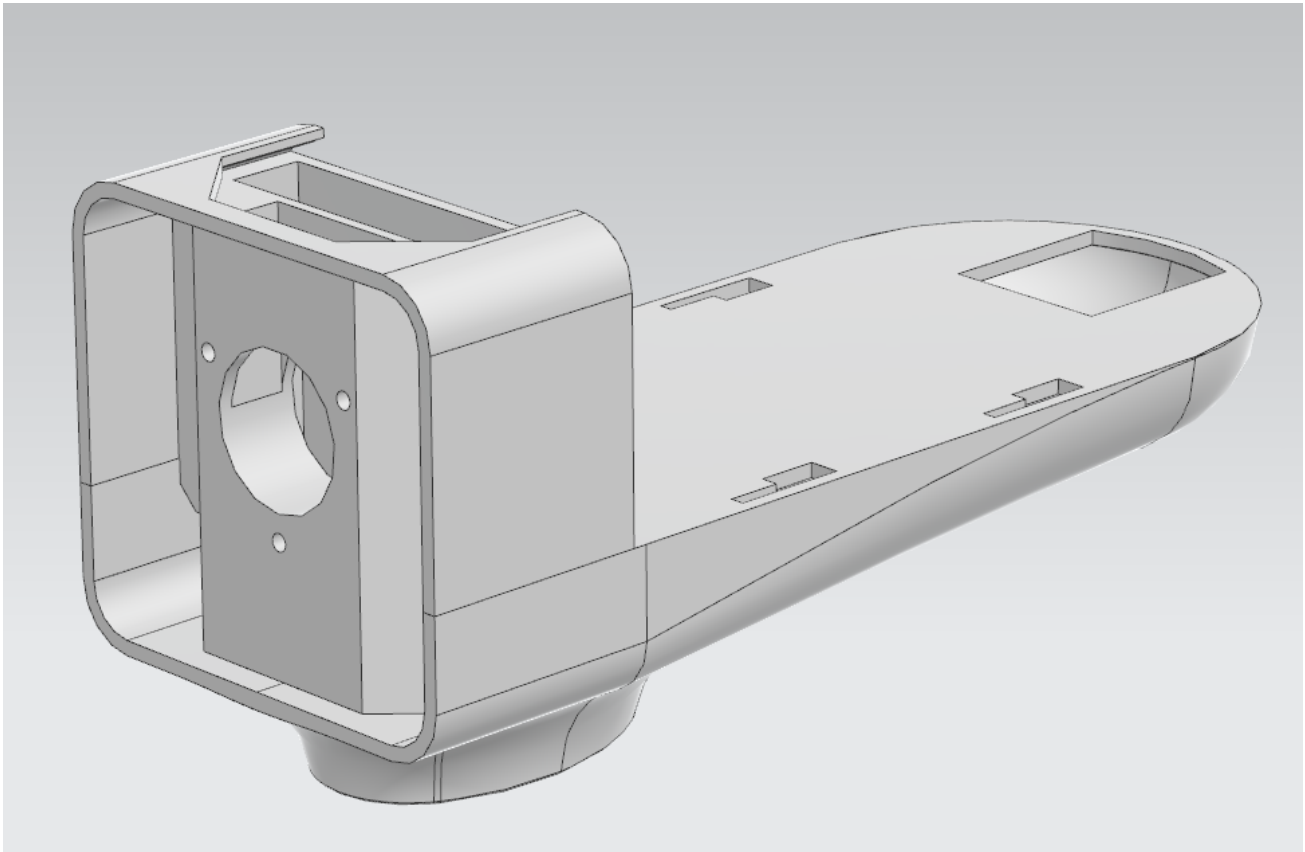

Figure 5.4 Main head part

When it came to designing the main head part, the sizes that of the components that would be implemented in it were researched and discussed. Namely, the initial size estimation of the microcontroller and PCB as well as the Cartridge and Nozzle.

The size consideration of the PCB and micro controller that were determined by the electronics team were 75*120*25mm. Not including the wires for the electronic parts. Due to its size, it is placed behind the centre axis of the ergonomic grip in line with the elbow. This was done to reach a well-balanced product. Placing it in line and above the wrist of the user will additionally benefit the handling of the device. Giving it a slim profile to avoid it bumping into the user itself or other things while handling the device. Additionally, it was chosen that the main head part to have a “second floor” for cable management. The first is where the PCB can be mounted as well as the slots for the electronic covers. The first floor also has two major openings both near the cartridge slot and the aft of the device. Here is where the “second floor” comes into play in its role of cable management, allowing cables to be routed away from the PCB. In the lower part, the slot for the connecting pins is located and they are e glued into place. They establish the connection between the cartridge and the microcontroller.

The Main head part is split into two different parts. The base of the Main head part and the Cartridge slot part. This was done for manufacturing reasons, as 3D printing it as one art would have led to incredibly complicated removal of the printing support structure. As well as a heavily decreased the printing time by being able to print both parts on two different printers at the same time.

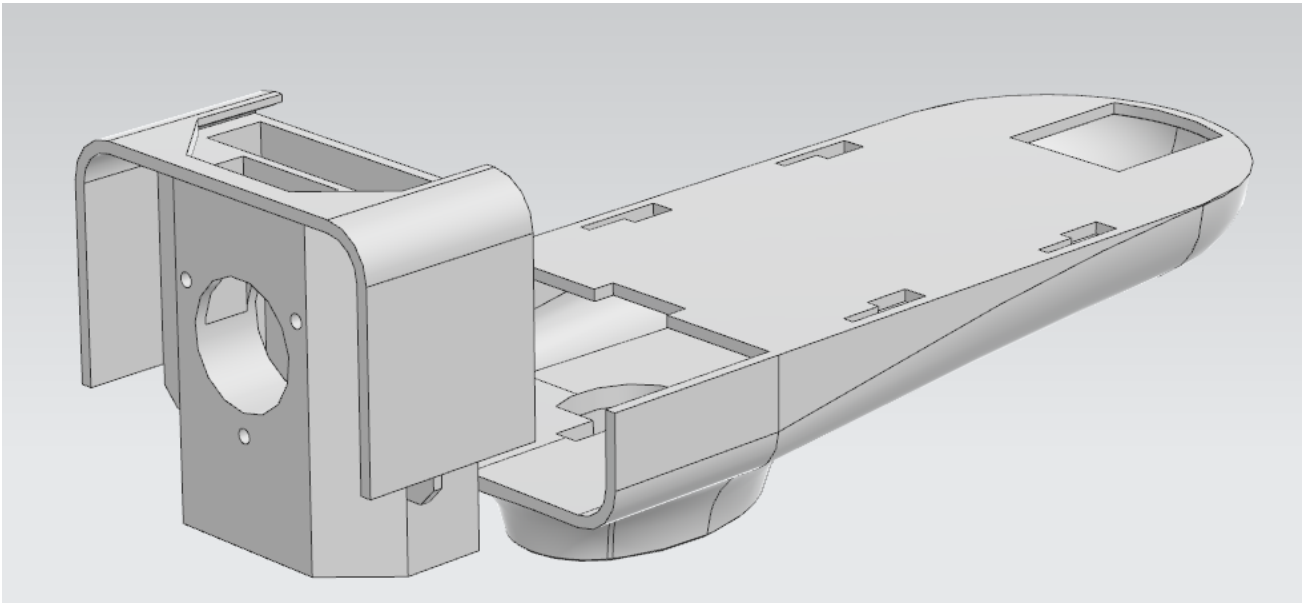

Figure 5.5 Main head part - exploded

The Cartridge slot part is placed forward of the center axis of the handle, this was done to balance the design and improve ergonomics. The slot for the cartridge is measured to fit it with minimal tolerances. It guarantees that the Cartridge while in use does not get loose or lose its connection with the electronic parts via the pins. In front of the slot, there is the connection for the nozzle and filters at the air in and outlet. The air in- and outlet is designed such that air coming in from the nozzle will pass through the first filter and with its momentum continue forwards towards the membrane cartridge. After the air has passed over the membrane it will exit the device through a second filter positioned at the top. On the side of the cartridge slot, itself are the exterior walls to create a flush exterior. These walls have connecting supports that both increase its rigidity while also acting as guides during assembly. Ensuring the alignment of both parts when glued together during assembly.

5.5.2 Front cover

The Front cover is a friction fitted piece at the front of the device. Its main function is to hold the spirometer nozzle in place.

It does so by having an extrusion that is sized to the desired Spirometer. In this version of the Prototype, it is a Spirometer nozzle of 28mm in diameter. The Front cover ensures it's aligned with the membrane of the cartridge. As the circular filter placed in between the front cover nozzle and Cartridge slot needs to be accessible to be exchanged during servicing of the device the Front cover needs to be detachable. For this reason, it was chosen to go with friction fitting the front cover to the device. This allows for seamless edges between parts when installed correctly. Disregarding the usage of bolts or other fasteners. Provided the manufacturing and assembly of the parts is up to standard.

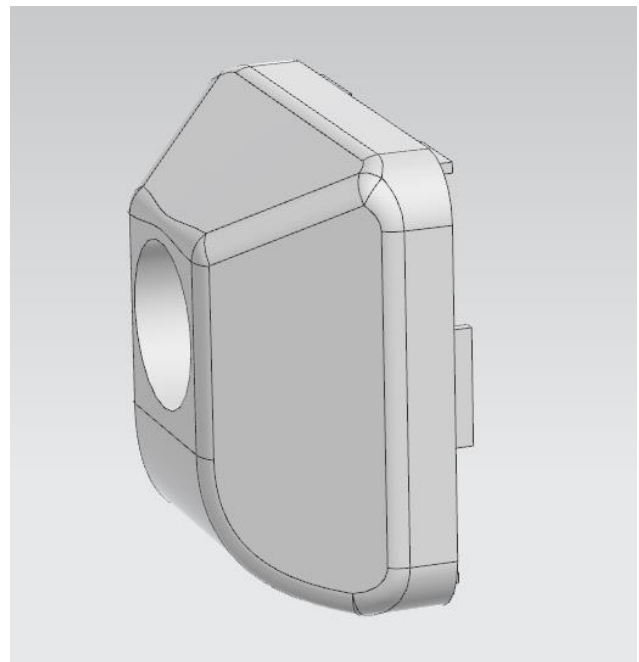

Figure 5.6 Front cover

In the case of the lower part of the Main head had some warpage to it in the front and back end. This was due to the quality of the 3Dprint. However, to make the prototype work an additional piece of paper was glued to the lower connecting piece of the Front cover to overcome the misalignment and successfully friction fit the parts together.

5.5.3 Electronic covers

The electronic covers can be found on top of the Main head part and they consist of two different parts. Both have the primary focus on covering electronic components on the inside of the device as well as having a flush exterior with the rest of the parts when closed. The first cover placed closest to the front, is also responsible for holding in place the process indication LEDs. Because of that reason the LEDs are positioned in such a way that they are angled towards the person testing someone else. Allowing for a clear line of sight for the user. Additionally, it allows for a smooth transition between the thinner back part and the front of the head of the device. Both benefitting the weight distribution as well as aesthetic appearance that the team was in favor of.

Both the first and second covers have keyed extrusions fitting into matching slots placed on the main head part. This prevents them from coming loose during the operation of the device.

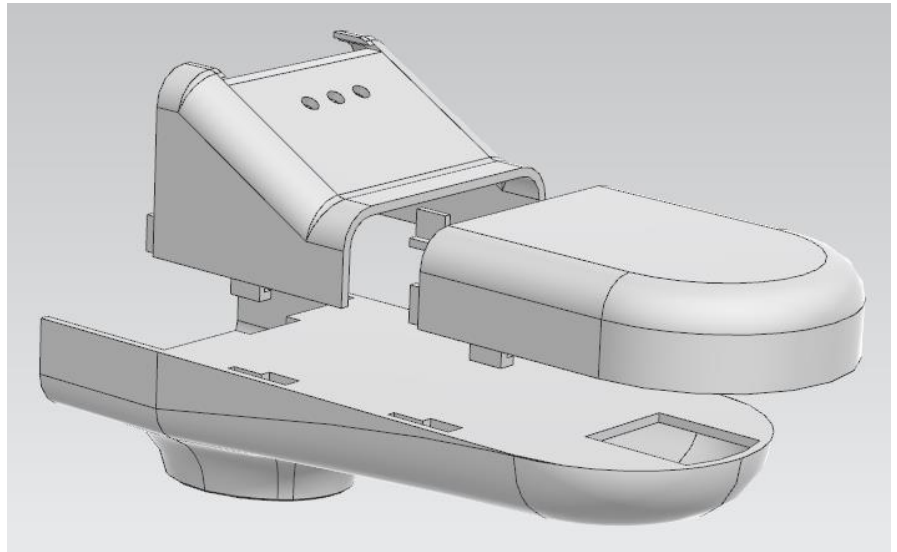

Figure 5.7 Electronic covers

For an additional secure fit, they are designed with their tolerances to induce friction when pushed into their closed position. Having two covers adds a few benefits during assembly and servicing of the device. In the initial assembly, both the electronics and the first cover can be placed as intended without the use of any kind of fastener. After which the second cover is added to close the device and lock it in place with friction. When servicing or checking the electronic components only the second part has to be removed by hand; circumventing the need to take off the entire cover each time.

5.5.4 Filters

In our design, we have two filters present. Both filters are designed to be replaceable and generally serve the purpose to keep out unwanted debris from coming in contact with the Membrane.

The filter placed between the nozzle piece and the cartridge slot is referred to as the first filter. The first filter is held in place by pressure applied by 3 bolts that fasten the circular filter cap to the cartridge lot. Similarly, to how it is done to clamped gaskets. The first filter serves primarily to keep out unwanted debris from the person blowing into the nozzle during testing. Debris such as water droplets could affect the performance of the membrane during testing, possibly resulting in a false positive or false-negative result.

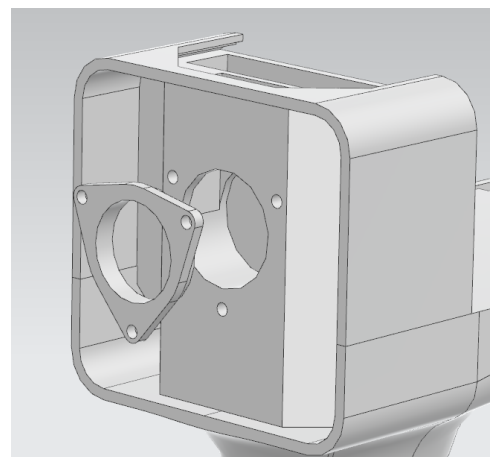

Figure 5.8 Filters

The circular filter cap itself serves a secondary purpose as well. When placing the spirometer nozzle into the device it should be pushed back until it is in touch with the filter cap. Thus, allowing the user to experience physical feedback as the nozzle cannot be moved any further by it no longer being able to be moved. When this occurs, the nozzle should be in the right position.

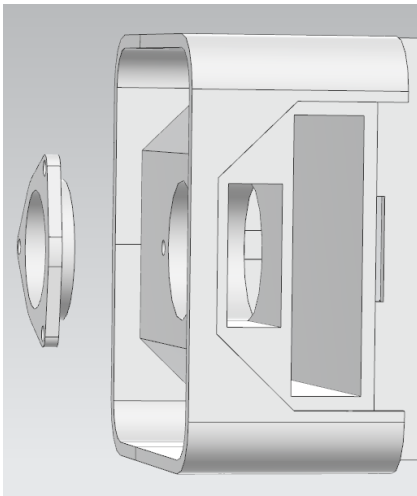

Figure 5.9 Second Filter

The second filter is placed on the top, covering the exhaust vent. It leads the exhaust of the tested person's breath upwards and parallels away from the Cartridge slot. The second filter serves two purposes. It is designed to keep unwanted debris from entering the device from the outside. Such as dust and water droplets or other unwanted debris that can be filtered out. On the other hand, it serves as an additional protection layer against the spread of Covid or another type of infection that is being tested for. If the person that is being tested is proven to be positive and blows into the device, it will be most likely caught and filtered out. Alternatively, without the first and second filter installed the person is likely to blow into the device and possibly spread the infection via the exhaust vent of the device.

The prototype pieces of surgical masks for the filters were used in order to test and gauge if the implementation of filters into the device is useful. For the second filter, it was envisioned to be a small rectangular cartridge that would fit tightly on the exhaust vent and would be easily replaceable. In the current prototype, this was not possible and gluing the filter piece directly to the device was chosen as an adequate substitute due to time constraints and prioritizing the ability to test the design of the device by the 17.12.2021 was deemed of greater significance.

5.5.5 Slide cover

The slide cover is placed on top of the Cartridge slot. Its purpose is to hold both the cartridge securely in its place as well as the envisioned second filter cartridge. By simply sliding the cover the Cartridge can be covered or opened to allow for access without the use of any additional tools. It is intentionally inserted through the top of the first electronic cover. This aids during the assembly process of the device as well as adds additional friction that secures the slide cover and electronic front cover in place.

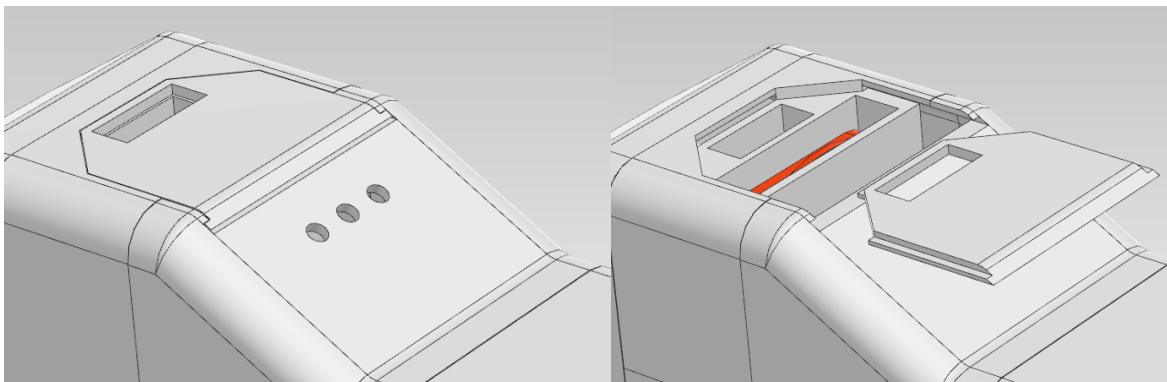

Figure 5.10 Slide Cover

5.5.6 Battery compartment

The battery compartment acts as a base for the whole design. It is connected to the other parts by the ergonomic grip. It serves as a holder for the batteries, the on/off switch, and the battery indicator LEDs.

The main considerations while designing this part would be the size, it was designed to be just the right size to be able to accommodate the battery holder (61.5 mm x 57 mm x 16 mm), the circuitry and cabling required for the on/off switch and the battery indicator. The battery holder is attached to two rectangular extrusions that are centered in the middle of the inside of the roof face. Ideally, it would be fastened to those extrusions by M3 screws, however, due to printing issues this was not possible, and it was superglued instead. In the front of the part, two rectangular extrusions act as a holder for the battery indicator circuit board. It was supposed to be held in place by M2 screws, however, this could not be done as the PCB didn't arrive on time and there was not enough space on the Veroboard circuit to drill through it, so superglue was used instead.

The battery indicator LEDs and the on/off switch are located at the back of the part. 3 R1.5 mm holes serve to friction fit the LEDs and a rectangular hole with R1 mm holes serve to fasten the switch, but due to an error occurring while measuring the switch dimensions the R1 mm holes do not align perfectly, and the superglue had to be used to keep the switch in place. An additional extrusion is located in each corner on the inside of the battery compartment that is horizontally aligned with the ground. Each extrusion has a R1.5mm hole that is used to fasten the Lexan bottom cover to the battery compartment with M3 screws. Lastly, there is a R14.9 mm hole on the top of the part that allows the power cables to be connected to the rest of the device. This hole is enclosed by extrusion with an inner radius equal to 17.6 mm and an outer line that is identical to the base of the handle to allow for a seamless fit for the ergonomic handle.

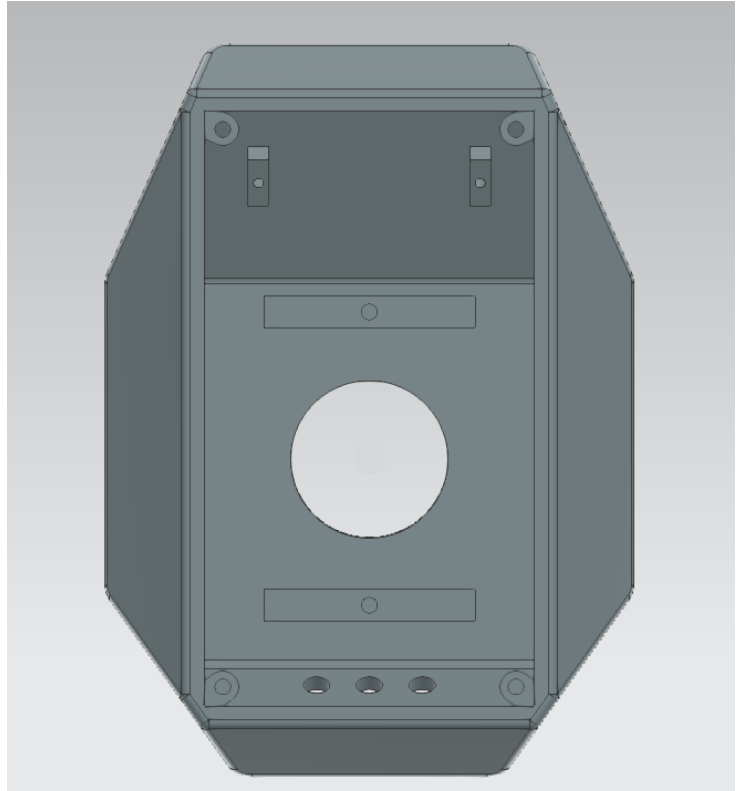

Figure 5.11 Battery compartment bottom view

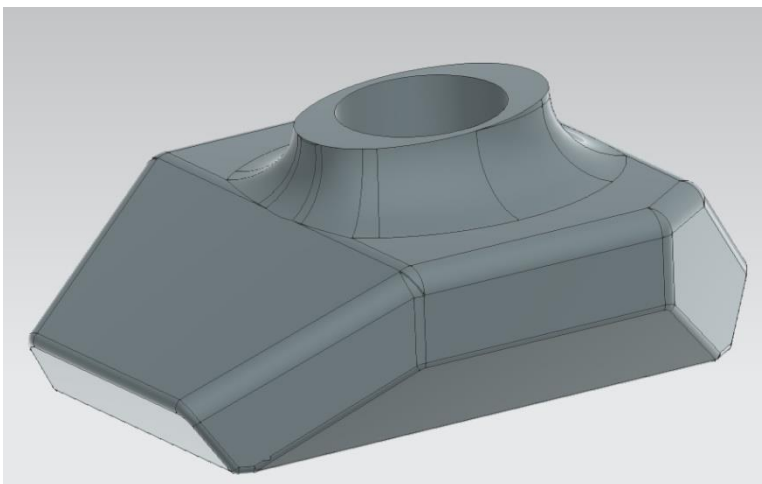

Figure 5.12 Battery compartment

5.5.7 Handle Design

The handle is the centrepiece of the design, it connects the top and the bottom parts. The purpose is to allow the user to comfortably grip and carry the whole device. Its design is the combination of the 3D scan of the author's hand and a pre-existing ergonomic handle design. The handle went through multiple designs before the group reached a consensus. There were two types of handles – one type was based solely on the 3D scan and the other types were inspired both by the 3D scan and by already existing ergonomic handles.



Figure 5.13 3D scan design



Figure 5.14 Var A



Figure 5.15 Var B



Figure 5.16 Var C

3D scanning

The 3D scanning has been done on 3D System scanners that have been lent to the group. The scanning setup was rather rudimentary. It consisted of the scanner placed on a table in a dim room to reduce the amount of light shining onto the scanned object. Opposite of the scanner at a distance of roughly 30 cm was placed a box that would bring the object to be scanned to “eye-level” with the scanner. Then on top of this box would be placed a paper that had a circle divided into degrees printed on it. In the middle of this paper a short circular object was placed that was used to rotate the object by 20° in between scans to get an even imprint scan. The object being scanned was a plastic tube evenly covered in plasteline. Before the scan commenced a group member would tightly grab onto the plasteline, leaving a grip imprint. The scanner would transfer each scanned data into Design X – an application made by 3D systems. The data was then manually merged and cleaned, any holes or missing patches would get filled and the result was a 3D mesh.



Figure 5.17 3D mesh

Two methods were utilized to export the mesh into an STL file that can be edited and printed. The first method was to create regions on the mesh that would then get mapped by the program, allowing for a creation of a solid body. The second method was to create a 3D sketch that would map the areas that should be turned into a solid body.



Figure 5.18 first method

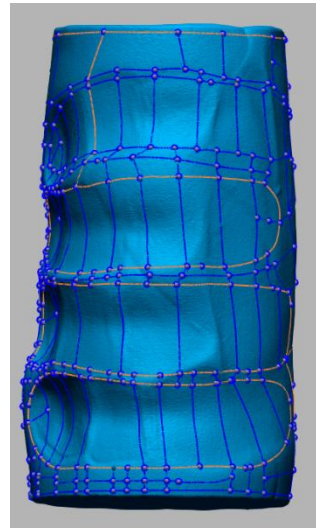

Figure 5.19 second method

After the mesh has been converted into a solid body (using both methods) the design was coarse, the resolution was low and the authors were unable to fix these issues, as such it was abandoned. However, the scans themselves served as a rough guideline for the final design, such as the finger placement, length, and thickness.

Final design

As mentioned previously the 3D scan design could not be used, the variation A design was usable, however, there were uncertainties as to whether it could support the upper part of the device. So, after discussing variations B and C, the authors have decided to choose the variation C handle design as the primary design – the main reason being that the variation C design was at the time more polished than the variation B design.

The base of the handle is an ellipse with a length of 55 mm and a width of 40 mm. From this base a body with the height of 116 mm was created. On one side of this body, four grooves were added to accommodate the fingers of the hand while the other side was bent for a more comfortable wrist placement. A R15 mm hole was made through the handle to make space for the cabling. This hole was enclosed by a circular extrusion both on the top and the bottom, allowing the handle to be slotted into the battery compartment and top part respectively. A 3° cut was made to each end of the extrusions, creating a slight bend to provide for a more neutral wrist posture while holding the device. A R3 mm hole was created over the index finger groove to accommodate the button head. The rest of the button is placed into a holder on the inside of the handle. Lastly, a groove was made, starting from the top of the handle all the way to the button hole to create an easier slotting of the button during the assembly.

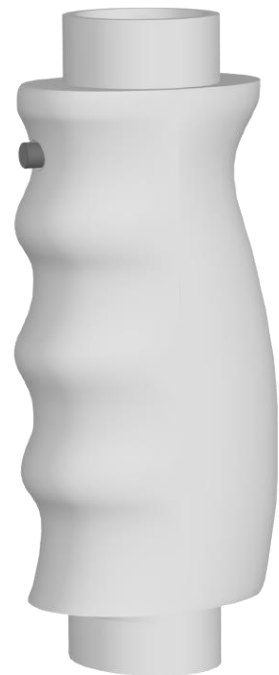

Figure 5.20 Var C design with button

5.5.8 Membrane Cartridge

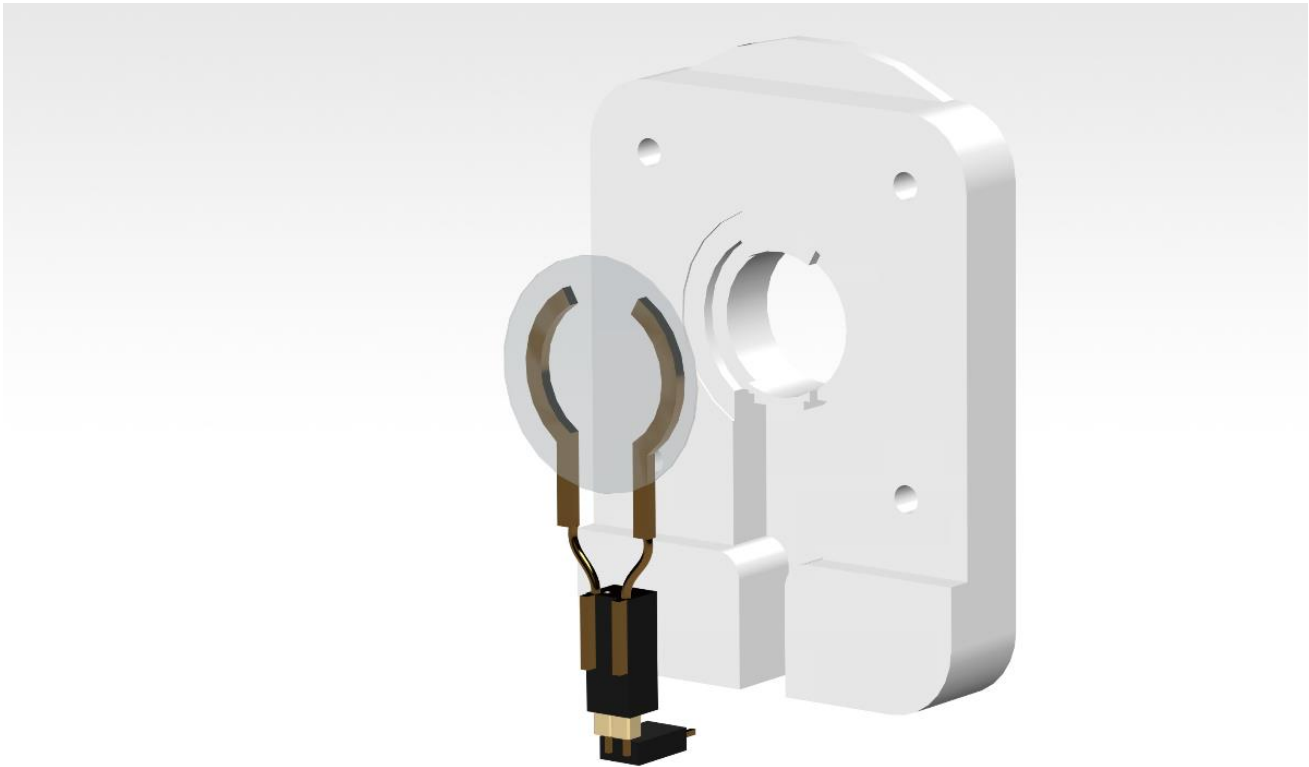

Figure 5.21 Membrane Cartage

The Cartridges are designed to be exchangeable by the user within a short time without the usage of any tools. Both the cartridge design for the 25.4mm and 14mm versions must fit into the cartridge slot of the Breathalyzer and be able to be exchanged by a hand of an average person.

To be able to use the Membranes for testing the position must line up with the Breathalyser nozzle and must allow for the centre of the membranes to be exposed to allow for its vibration. An additional requirement of the cartridge design is that it must allow for a stable, non-permanent connection between the membrane and the microcontroller. All materials in touch with the connecting parts to the membrane as well as the membranes themselves are required to be nonconductive.

When it came to designing the cartridges, it was decided that the width of the device had to be a maximum of 50mm with a total height of 70mm and depth of 13mm. The height and width of the cartridge allowed for both enough spacing to fit in within the dimensions of the Casing as well for leaving enough room for manually inserting the connectors into the Cartridge during assembly. Although the cartridge could have been designed with a narrower width, it was decided to keep it at those dimensions. As it was found during handling, manufacturing, and application of the coating to the membrane that the larger dimensions were ideal for carrying it by hand or clamping the cartridge down without risking touching or damaging the membrane during the application of the coating.

The copper contacts were designed to be placed within the cartridge in an extrusion while covering the contact area of the membrane. The pins are 1.5mm thick and are placed to be submerged 1.4mm within the cartridge while the membrane is placed on the exposed 0.1mm of the copper contact. This configuration ensures that when pressure by the acrylic/Lexan plate is applied to the membrane and will establish contact. The membranes that are placed onto the contacts are approximately 0.33mm thick.

When placed onto the pins it is elevated by 0.1mm over its surrounding material. This was done so it could be compressed between the pins and the acrylic/Lexan plate in the Cartridge which would ensure that the membrane would not slide off the pins as well as limit the amount of pressure that could be applied by the acrylic/Lexan plate.

The Cartridge has a before-mentioned acrylic/Lexan plate that provides pressure onto the membrane. They were chosen as they allowed for visual inspection of the membrane during inspection, allowing to check whether or not the Membrane had moved or lost contact to the pins.

The cartridge connects the membrane with the microcontroller via a female connector at the bottom which slots onto male connector pieces at the bottom of the Cartridge slot. It's proven in testing to be a reliable and sufficient connection and the microcontroller.

At the top of the cartridge can be found a 5mm extrusion. It is designed as a point to take the Cartridge out of the Cartridge slot by hand.



Figure 5.22 Membrane Cartridge (assembled)

6 Business Research

6.1 Intro

The two main objectives for a business context in this project were to identify the market needs for such a device and perform interactive prototyping with potential users. Both objectives were fulfilled and, in some cases, done simultaneously via already mentioned questionnaire.

Besides the required objectives, the assumptions about the market size and market penetration and Importance-Performance Matrix have been completed. The market penetration calculations and assumptions provide valid information about the potential size of the market and possible space to grow. The matrix gives out knowledge about features important to the customers and their performance in comparison to the competition.

6.2 Competition Analysis

6.2.1 Identification

Identifying competition has been a difficult task since a lot of companies are competing with different quality factors, use different technologies or focus on providing services to various customers in different countries. The most reasonable way to find competitors was to set multiple features that are the most important with the potential field of application in mind.

The most sought-after feature during the research was Point-of-Care method. Although it has already been mentioned in this report, Point-of-Care method in simple words means that the screening and treatment/identification is completed during a single encounter outside a laboratory setting. Another feature included in the research was a timespan from a screening to a test result. There is no specific time range for the quick test results in general, however; in this research the decision was to set the upper limit to approximately 1 hour. Other features considered were reusability of the test, testing kit or the device and mobility to a certain point.

This narrowed it down to 3 potential competitors so far who compete within the Point-of-Care testing using different approaches. All companies are US based, however, able to compete on the European market. The companies are namely:

1. **Quidel Corp.**
2. **Mesa Biotech (now Thermo Fischer Scientific)**
3. **Talis Biomedical**

6.2.2 Information

To analyse competition, the crucial part is to gather intelligence about them. What kind of company they are? What products are the ones this project is competing with? How have they been performing in the past year? How does the company differentiate? are the questions that must be evaluated to get a better idea who this project stands against.

6.2.3 Quidel Corporation

Company & Branding

Quidel is a California based company focused on diagnostics healthcare. The company was first formed in 1981, launched its product line in 1985, and merged in 1991 with Monoclonal Antibodies creating Quidel Corporation that have been around ever since.

In the first decade since its foundation, the company has battled various patent infringement lawsuits while trying to establish its name on the market. After that, the company has been growing and acquiring other diagnostics companies along the way to increase its market share. The very recent one has been announced in December 2021 where Quidel Corp decide to acquire Ortho Clinical Diagnostics Holdings for \$6 billion in cash and stock¹⁷. This acquisition will help Quidel to increase the range of COVID-19 antigen and antibody tests they are able to offer.

When it comes to the branding and how the company tries to portrait itself, the best to analyse this was to look at their “Guiding Principles”. The principles are divided into 3 sections that focus on how the company protects itself in the marketplace, how the company grows and how it thrives.¹⁸

Guiding Principles



Figure 6.1 - Guiding Principles

By looking at the principles, customer satisfaction and customer service are very high on the importance list. Another important feature is reliability, compliance and inevitably performance that helps the company stay competitive within the market.

Differentiators

This element of the analysis is focused on things that help the company to differentiate itself from the others. Quidel is a large company and most likely offers the widest range of products out of the chosen competitors, which could already be considered a differentiator. However, since this project and product is about COVID-19, the main differentiator for Quidel is their custom School Testing Program and Employee Testing Program¹⁹.

¹⁷ <https://www.reuters.com/markets/deals/quidel-buy-ortho-clinical-diagnostics-6-billion-2021-12-23/>

¹⁸ <https://www.quidel.com/about>

¹⁹ <https://covid19.quidel.com/>

What this essentially means is that company can provide end-to-end solutions for schools and workplaces suitable to different needs by using their already available or new technology. This makes Quidel way more attractive for new potential customers and enables them to explore new areas of business and possibly even lead to product innovations.

Products

Their products fall into 5 different categories:

- Lateral flow
- Direct fluorescent antibodies (DFA), with expertise in infectious disease and virology
- Micro-titer production, with a focus on bone and complement pathway markets
- Fluorescent immunoassay products (Sofia)
- Molecular diagnostic products

Besides these 5 categories, there are products that are specifically related to COVID-19:

- Lyra SARS-CoV-2
- Lyra Direct SARS-CoV-2
- Sofia SARS Antigen
- Sofia 2 Flu+SARS Antigen
- QuickVue SARS Antigen
- Solana SARS-CoV-2
- QuickVue At-Home OTC COVID-19 Test

The product family that could potentially pose a threat to this project is Sofia. It fulfils the requirements of the PoC method, the test results are given within the 15 minutes²⁰, and the device appears to be mobile, however it must be stationary when the test result analysis is conducted. This product family has been around for some time and has been also used for detecting different diseases (Lyme, Influenza, Legionella) using lateral-flow technology or fluorescent immunoassay²¹. One of their recent test kits that can be utilized with Quidel Sofia, and Sofia 2 Analyzers is SARS Antigen FIA test kit. (FIA stands for fluorescent immunoassay).

Financial Performance

The financial performance for Quidel has been very positive and in the past 5 years (since 2016) the company has increased its market by approximately 900%²². The stock price all-time high was in 2020 when the price per one stock reached \$301.96²³. The stock price was undoubtedly a consequence of incredible revenue increase that reached over 210% from 2019 to 2020 as can be seen in the Figure below. This enormous increase in sales can be tied to the pandemic and large demand for COVID-19 tests. Currently, the revenues from past 3 quarters amount to about \$1.06 billion²⁴

²⁰ <https://www.nih.gov/news-events/news-releases/nih-delivering-new-covid-19-testing-technologies-meet-us-demand>

²¹ <https://www.quidel.com/immunoassays/sofia-tests-kits>

²² https://www.marketwatch.com/investing/stock/qdel/financials?mod=mw_quote_tab

²³ <https://www.macrotrends.net/stocks/charts/QDEL/quidel/stock-price-history>

²⁴ <https://www.marketwatch.com/investing/stock/qdel/financials/income/quarter>

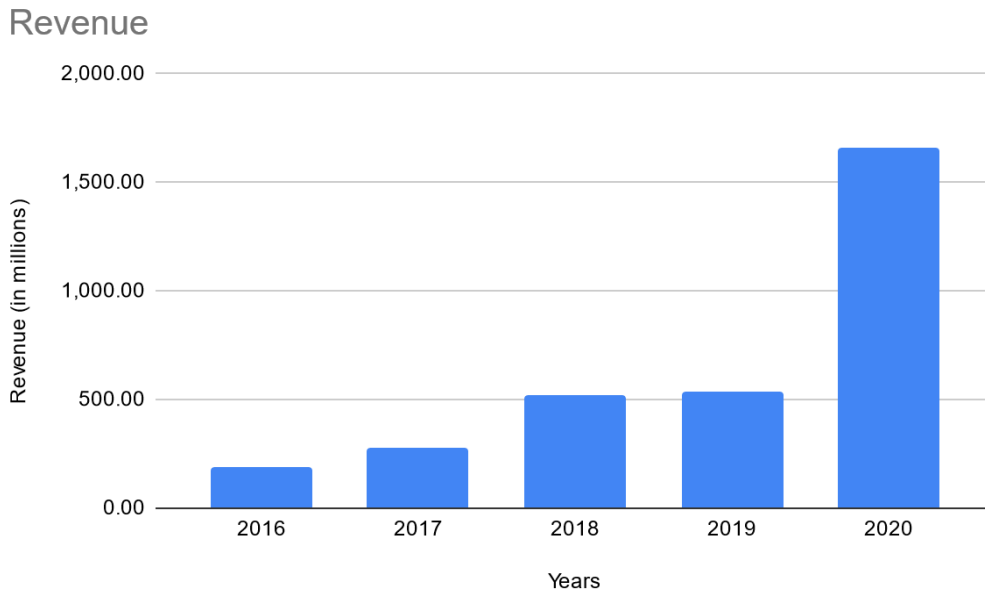

Figure 6.2 - Revenue Chart

Strengths & Weaknesses²⁵

Strengths	Weaknesses
<ul style="list-style-type: none"> ▪ According to Glassdoor and Indeed Quidel provides a decent working condition²⁶ ▪ Solid distribution network ▪ High product innovation ▪ Outstanding track record of integrating new businesses via acquisitions and mergers, streamlining its operations and building a steady supply chain ▪ Great response from customers and solid brand reputation amongst existing customers 	<ul style="list-style-type: none"> ▪ Publicly traded – a lot of bureaucracy, and long decision making ▪ Investor Satisfaction – new untapped markets might get refused due to uncertainty of ROI ▪ Poor forecast of demand and high rate of missed opportunities, resulting in a large inventory both in-house and in channel ▪ Due to M&As, Quidel struggles sometimes with successful integration of the new complimentary companies into their core business, especially smaller companies that have different work culture.

Figure 6.3 S&W Table

6.2.4 Mesa Biotech (now Thermo Fisher Scientific)

Company & Branding

Mesa Biotech was California based point-of-care molecular diagnostic developer that has been recently acquired by Thermo Fisher Scientific (TFS) and is now part of TFS’ portfolio. Now TFS is a large multinational holding company involved in scientific instrumentation, reagents and consumables, and software services. Today the company is composed of a range of brands. The brands are specifically²⁷:

1. Thermo Scientific
2. Applied Biosystems

²⁵ <http://fernfortuniversity.com/term-papers/swot/nyse/2029-quidel-corporation.php>

²⁶ <https://www.glassdoor.com/Reviews/Quidel-Reviews-E1469.htm>

²⁷ <https://corporate.thermofisher.com/us/en/index/about.html>

3. Invitrogen
4. Fisher Scientific
5. Unity Lab Services
6. Patheon

The company has had a long history of mergers and acquisitions which essentially have gotten the company where it is right now. For instance, the company itself was created by a merger of Fisher Scientific and Thermo Electron in 2006²⁸. The most recent acquisitions include the already mentioned Mesa Biotech or the Belgium-based viral vector manufacturer, Henogen SA, from Groupe Novasep SAS²⁹. One of the biggest acquisitions have happened in 2013 when TFS agreed to pay US\$13.6 billion for Life Technologies Corporation after a competitive bidding with Hoffman-La Roche³⁰.

TFS brand and reputation has gone through lots of a ups and downs. Most recently, the company has been accused and reported to sell its equipment to security services in China for use in what was alleged as part of a genetic surveillance program, despite the ban and announcement by the company³¹. This has impacted brand's reputation and the customer base did not take that in positively causing a backlash which

Differentiators

On the first look, the most significant thing that TFS does differently is the M&A strategy. Every bigger company does mergers and acquisitions to in simple words prolong the Maturity phase of a Life Cycle³². Other reasons might be elimination of the competition, increase efficiency by combining business activities or increase supply chain pricing power by vertical mergers. TFS has seemingly made the M&A business their ethos and the company has been acquiring different businesses close TFS' core business on almost yearly basis³³.

Products

TFS' product portfolio is enormous and differs from brand to brand. Not every brand under TFS is in direct competition with this project. Only Thermo Scientific and a certain range of products under that brand are considered a competition³⁴. Namely, the products that could potentially pose a threat are:

1. TaqPath COVID-19 Diagnostic Solution
2. Accula SARS-CoV-2 Test

Accula being a product of a recently acquired Mesa Biotech, has provided TFS with a new PCR technology called Oscillating Amplification Reaction (Oscar) that shortens cycling times while providing the same or better-quality test results as any other lab-based RT-PCR test.³⁵ The Accula solution is composed of a dock for the test analysis and testing kits that can be bought separately. Accula also provides one of the lowest limit of detection within the Rapid NAATs (nucleic acid amplification test). Moreover, Accula tests have acquired CE marking in the EU, thus they can be sold in EU, as well as the Emergency Use Authorization (EUA) by FDA. The tests have a waiting time for the result of approx. 30 minutes.

²⁸ <https://www.biospace.com/article/releases/merger-of-thermo-electron-corporation-and-fisher-scientific-international-inc-completed-forming-b-thermo-fisher-scientific-b/>

²⁹ <https://www.biospace.com/article/thermo-fisher-scientific-acquires-viral-vector-manufacturing-business-from-novasep/>

³⁰ <https://www.reuters.com/article/us-lifetechnologies-thermofisher-idUSBRE93D0A620130415>

³¹ <https://www.nytimes.com/2020/06/17/world/asia/China-DNA-surveillance.html>

³² <https://www.forbes.com/sites/richardkestenbaum/2017/12/26/this-is-why-companies-make-acquisitions/?sh=6f65347c37a4>

³³ <https://ir.thermofisher.com/investors/financials/recent-acquisitions/default.aspx>

³⁴ <https://www.thermofisher.com/us/en/home/clinical/clinical-genomics/pathogen-detection-solutions/covid-19-sars-cov-2.html?SID=fr-covidtest-main>

³⁵ <https://www.thermofisher.com/us/en/home/clinical/clinical-genomics/pathogen-detection-solutions/accula-rapid-pcr-system.html>

Financial Performance

TFS’ sales revenue has been following a steady growth in the past 5 years. Since the publicly available data on financials is for the whole company, the numbers are significantly higher than with any other competitor. The stock price has also reflected the healthy growth when in the past 5 years (since 2016) it has increased by approximately 500%³⁶. The chart below shows the revenues in the past 5 years:

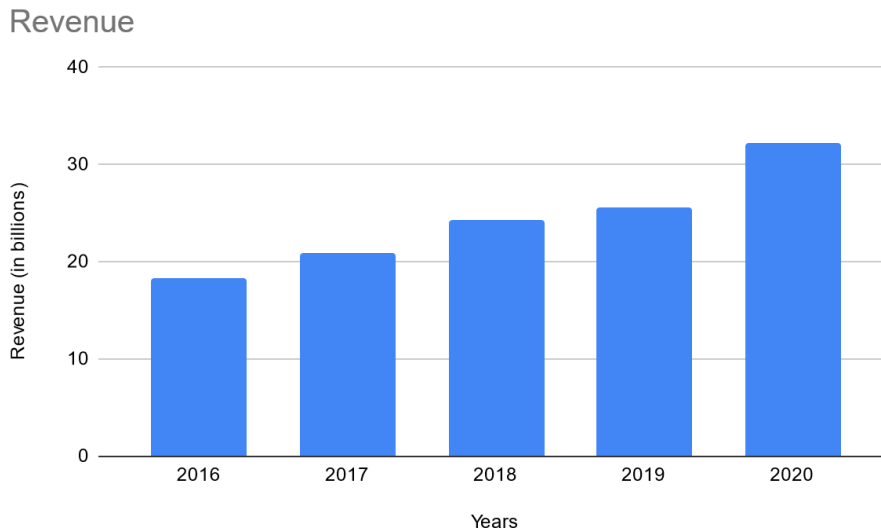

Figure 6.4 Revenue Chart

The sales revenue for the past 3 quarters in 2021 amounts to USD\$28 billion.

Strengths & Weaknesses³⁷

Strengths	Weaknesses
<ul style="list-style-type: none"> ▪ Company with an international presence ▪ The largest portfolio of products out of all mentioned competitors ▪ Expansion via acquisitions ▪ Accula solutions providing highly precise results with low limit of detection ▪ Access to large amounts of patents and technologies ▪ Financial resources – high sales revenues resulting in a lot of free capital ▪ Dominant presence in emerging markets ▪ Successful track record of innovative products ▪ Reliable network of suppliers 	<ul style="list-style-type: none"> ▪ Wide portfolio of products that are heavily dependent on technology – change in a technology might make an entire product line obsolete ▪ Struggles to integrate newly acquired businesses into TFS’ core business and to follow the same vision and objectives ▪ Organization structure is not flexible and only compatible with current business model ▪ Investment in R&D not comparable to the leaders in the industry ▪ High spending on training and development of their employees, higher than industry standard

Figure 6.5 S&W Table

³⁶ https://www.marketwatch.com/investing/stock/tmo/financials?mod=mw_quote_tab

³⁷ <http://fernfortuniversity.com/term-papers/swot/1433/164-thermo-fisher-scientific.php>

6.2.5 Talis Biomedical

Company & Branding

Talis Biomedical Corp. is a publicly traded company based out of California with expertise in developing and commercializing products involved in molecular testing for infectious diseases. Their focus is PoC testing within Respiratory Health, Sexual Health and Women's Health using expertise in molecular biology and chemistry, bioinformatics/assay design and end-to-end platform engineering. Talis is a relatively young company, founded in 2013 and gone public in February 2021, which can still be considered a start-up.

Differentiators

Company puts a lot of effort into developing suitable software integration for every customer. Besides that, the user interface on the touch screen of their device – Talis One, is very simple and it walks the user throughout the whole process from testing to reporting. The device also comes with a built-in modem for additional connectivity and cloud applications³⁸.

Another way Talis tries to differentiate itself from the competition is the customer experience. Having a live support available to help customers with any questions regarding the setup, maintenance or anything related to their product makes them stand out.

Products

Talis Biomedical so far offers only one solution, already mentioned Talis One™. The solution is composed of the testing instrument and a cartridge. The cartridge is single-use and contains a high sensitivity Isothermal Nucleic Acid Amplification (NAAT).

When developing the technology behind Talis One™, Talis focused on 3 main objectives – Speed, Ease-of-use and Accuracy. Although there are many ways to implement isothermal NAAT, Talis decided to focus on real-time loop-mediated isothermal amplification or rtLAMP³⁹. According to Talis Biomedical, this technique has enabled them to create a proprietary NAAT technology used in Talis One™ achieving high sensitivity, and low Limit of Detection.

Financial Performance

The company has been struggling to be profitable in the past 3 years. As with any young company, the initial investments almost always exceed the revenues in the first years of operation. Below are charts with the information about the revenue, expenses, and net income of Talis Biomedical from the past 3 years. As it can be seen, the expenses, mostly composed of the R&D expenses, exceed the revenue by far, making the net income negative except for the year of 2019.

³⁸ <https://talisbio.com/talis-one-point-of-care-instrument/>

³⁹ <https://talisbio.com/talis-one-technology/>

According to the financial reports from 2019, the only reason why the net income came up in black numbers is the Net Financing Cash Flow of over USD\$39 million. In comparison that same component was only USD\$8 thousand in 2018.

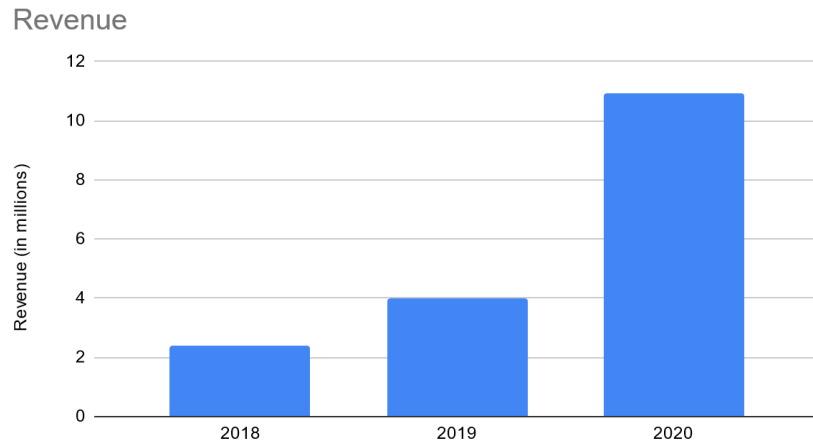

Figure 6.7 Revenue

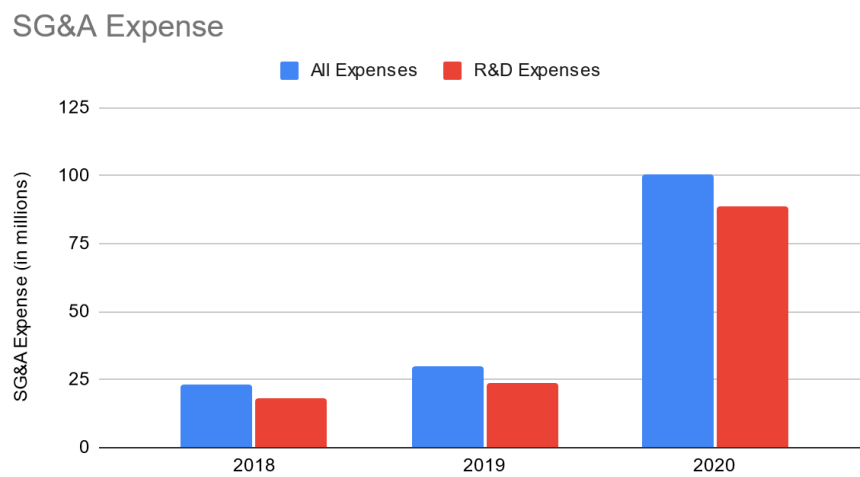

Figure 6.6 SG&A Expense

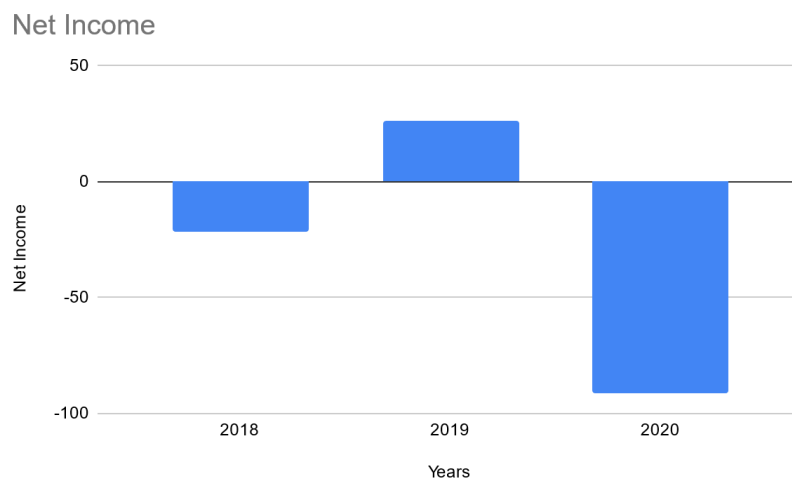

Figure 6.8 Net Income

Strengths & Weaknesses

Strengths	Weaknesses
<ul style="list-style-type: none"> ▪ Young company with a lot of talent and people with plenty of experience in the board ▪ Proprietary rtLAMP technology in the device ▪ Customer driven ▪ Custom software solution 	<ul style="list-style-type: none"> ▪ Only one device out now ▪ The software solution is not ready for mass use ▪ High expenses in the past 3 years

Figure 6.9 S&W Table

6.3 Customer Research

6.3.1 Assumptions

Finding the right customer base always requires certain assumptions. In the case of this project, the task of finding the right customers for this product has been fairly challenging given the amount of moving parts.

The first decision was to focus on Danish market, mainly due easier to access to information and the fact that AmiNIC is based in Denmark, making it easier to to surpass barriers of entry that might cause problems abroad.

Next, two factors had to be taken into account: the fact that the parameters concerning COVID-19 are in a constant change in Denmark. Meaning one month the testing might be required when going to work, and the another month it might not be. The other factor considered is that the testing in Denmark, whether PCR or Antigen, is completely free of charge, which makes this product obsolete on the first look.

With these two factors in mind, the attention was aimed on finding industries, companies or places where the features of the device – mobility, safety, quick results, reusability, large amount of tests would be appreciated so much, that the price would not matter anymore.

The pandemic has been around since the early 2020 in Denmark. It has caused a lot of damage on the economy, society and individuals too. In order to get a hold of the number of infected people in Denmark, the government decided to put the rapid testing into hands of private healthcare providers.

The rapid tests provided by Carelink and Falck, depending on the region in Denmark, are single use tests with results available approximately 15-20 minutes after undergoing it.

The problem with these tests is the waste that is the byproduct of using them. Whether is the nasal swab, the testing kit itself or all the gloves the healthcare workers need to change every time they test someone.

With that said, the belief was that the device could replace or at least be an alternative for rapid tests that the private healthcare providers use. Unfortunately, the framework between the Ministry of Health, each region and Falck or Carelink is very complex and unclear. It is not evident how the buying of the tests works, whether the region buys them and for how much. A deeper investigation might uncover the inner works of the system, however; the complexity makes it currently obsolete for a further investigation. Be it as it may, the final decision was to abandon the investigation of this framework and focus on different areas that have been affected by the pandemic.

As far as the companies go, the pandemic has led to a lot of business to either closing down or fundamentally changing their ways of doing things. One of the things that has changed rapidly is how work is conducted – telework. Telework had been around even before the pandemic but in the past 2 years it has become a standard and ordinary feature for certain employees.

According to a policy brief conducted by European commission, 37% of employees in EU-27 work in occupations that can be technically carried out from home, or any other place besides the office. That percentage changes throughout the Europe, making Sweden number one with 59% and Romania last with 18%⁴⁰.

What caught the eye when reading through this policy brief was the other side of the spectrum of teleworkability, thus the high percentage of workers that cannot conduct their work anywhere else but on-site. This has sparked an idea for the implementation of this project's device.

The assumption was based on the fact that companies that require their employees to work on-site, cannot substitute them in any other way and would need them to be performing their tasks no matter what, even despite the pandemic. Now, the question proposed was which industries exactly require their employees to be on-site because the work cannot be done remotely. Fortunately enough, the already mentioned policy brief provides a figure that portrays the percentage of teleworkability by sector.

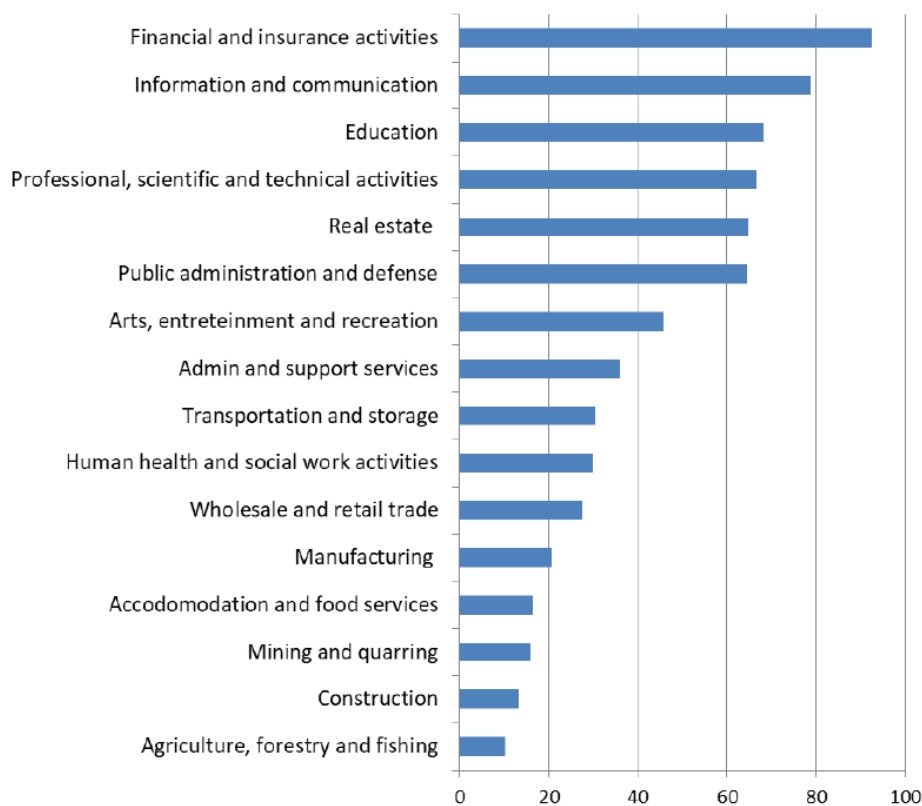

Figure 6.10 Teleworkability Chart

Based on the 16 sectors above, there are 10 sectors in which the teleworkability of the employment is less than 50%. The conclusion therefore is that still a large part of the workforce has to perform tasks on-site. Unsurprisingly, the employment in the sectors in question mostly involve manual labour, assembling, service, or transportation, all of which cannot be done remotely. Next step was to research the companies in Denmark within these sectors since they could serve as the premise for the potential customer base, market size and further calculation of the market penetration

⁴⁰ https://ec.europa.eu/jrc/sites/default/files/policy_brief_-_who_can_telework_today_-_the_teleworkability_of_occupations_in_the_eu_final.pdf

6.3.2 Potential Customers

The research of the companies was done using the Orbis database from Bureau Van Dijk. This database allows for a filtered search of companies and other entities. With the filters on location – Denmark, number of employees higher than 100, and Statistical Classification of Economic Activities in the European Community (NACE) being set to these ten industries:

- Arts, entertainment and recreation
- Admin and support services
- Transportation and storage
- Human health and social work activities
- Wholesale and retail trade
- Manufacturing
- Accommodation and food services
- Mining and quarrying
- Construction
- Agriculture, forestry and fishing

the search gave out 767 companies with available information about the revenues⁴¹. The reason why the filter on the number of employees was set to above 100 is the assumption that the more employees the company has, the worse the consequences could be if struck by the pandemic. It could be the possibility of the virus spreading through the company and causing shutdowns because of the high number of employees being infected or the administrative burden that company might undergo when scheduling a lot of employees for testing, or something else. Further investigation of these phenomena is portrayed in the second objective of Interactive Prototyping.

6.3.3 Market Size & Possible Penetration

Finding a correct information about the size of the market for a such device is almost impossible. There is some freely available information about the size of the market for PoC diagnostics devices, however; these numbers are irrelevant to this case. First of all, the market covers PoC diagnostics for not just infectious diseases, but also diabetes, glucose monitoring, cardiometabolic diseases and many more. That said, the dynamics in this market are very complex and it is unclear how much share of that market would be available for this device, and how much space there is for growth. Anyways, the size of the PoC diagnostics market in 2020, according to Fortune Business Insights, was around USD\$34.49 billion but again that includes all the PoC diagnostics methods for different diseases and purposes.

The approach to find the market size for this device was to derive it from the revenues of the potential customers, hence the list of the companies with the revenues. The easiest way to derive the market size is to find the average revenue for all the companies and then multiply it by the percentage that it is believed to be spent on the safety and health expenses concerning COVID-19. Unfortunately, there is no industry average percentage of revenue that companies spend on these expenses, therefore, different scenarios were developed to get the idea about the market size and potential market penetration.

⁴¹ Appendix 8.7 – List of the companies

Scenario 1

In this scenario the market size will be derived out of the average revenue of the 637 (out of 767 companies in the already mentioned list) companies with revenues less than €250M. This scenario is conservative since it disregards the companies with the highest revenues. However, it might be the most precise way to determine the market size since most of the companies' revenues are within the range of €0 - €250M. Below is a chart showing the frequencies of the companies' revenues within the determined magnitudes.

Frequency vs Magnitudes (all the companies)

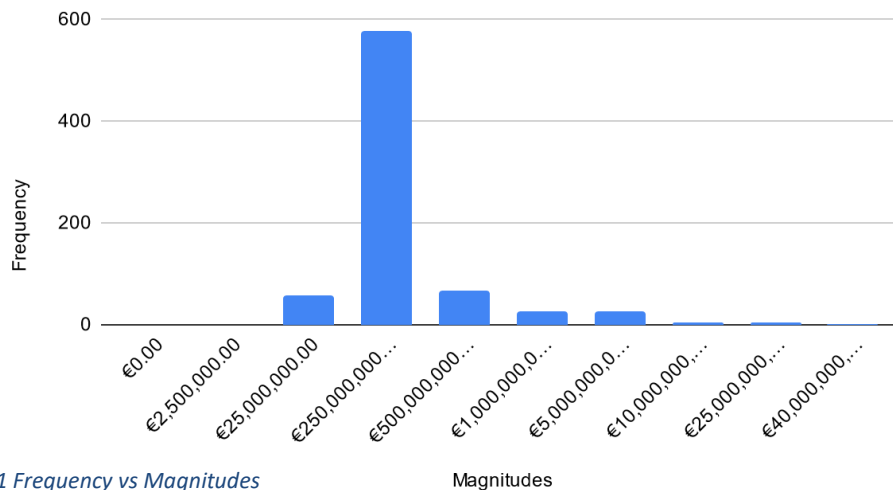

Figure 6.11 Frequency vs Magnitudes

The percentage of the revenue spent on healthcare in this scenario is 2% and the percentage that could be spent on COVID out of that 2% will be 5%. Calculations can be found below:

Avg. Revenue	2% of the revenue for healthcare & safety	Multiplied by 637	5% of the budget for healthcare/ Market Size
€82,031,795.90	€1,640,635.92	€1,045,085,079.80	€52,254,253.99

The market size therefore in this scenario is €52,254,253.99 which is still a large amount of money considered how conservative the calculation is. Next, the market penetration is a simple calculation that portrays the opportunity within the market size based on expected revenue. In this scenario, the choice was to calculate the market penetration with 3 different expected revenues.

Expected Revenue	Market Penetration
€1M	1.91%
€5M	9.57%
€10M	19.14%

In simple words, in case of the expected revenue of €1M and the market size €52,254,253.99, the market penetration would only be 1.91%, which also means that over 98% over the market would be available for growth. This calculation of course does not consider the competition and their market shares. The same principle follows for the expected revenue of €5M and €10M.

To get more diverse market sizes and market penetration using this conservative average revenue of the 637 companies with revenues lower than €250M, the only thing that would have to be changed are the percentage of the revenue spent on healthcare & safety and percentage of the budget for healthcare & safety that could be spent on COVID-19 related expenses.

Scenario 2

This scenario is a little less conservative than the Scenario 1. It only disregards the first 30 companies with highest revenues. The average revenue for the 737 companies amounts to €138,461,275.17. The percentages used in the calculations of the market size in this scenario were kept the same as in the Scenario 1, just for the sake of better comparison.

Revenue	2% of the revenue for healthcare & safety	Multiplied by 737	5% of the budget for healthcare/ Market Size
€138,461,275.17	€2,769,225.50	€2,040,919,195.95	€102,045,959.80

As it can be seen, the market size is almost the double in comparison to the Scenario 1, and only 100 companies were added to the calculation. That shows that once that €250M threshold is passed, the revenues start to increase rapidly. Furthermore, the calculation of the market penetration can be found below:

Expected Revenue	Market Penetration
€1M	0.98%
€5M	4.90%
€10M	9.80%

As expected the penetrations are almost twice less than the penetrations in the Scenario 1, which basically means that there is indirect proportionality between the market penetration and market size.

Scenario 3

The last scenario, and by far the least conservative scenario includes all the 767 companies from the list of companies included in the Appendix⁴². That means that the average revenue amounts to €357,012,230.84. That is more than 2.5 times more than the average revenue in the Scenario 2. That just shows how large the revenues are for the 30 companies that were left out in the Scenario 2. Charts below show the market size for this scenario using the same percentages again, and the market penetration as well.

Revenue	2% of the revenue for healthcare & safety	Multiplied by 767	5% of the budget for healthcare/ Market Size
€357,012,230.84	€7,140,244.62	€5,476,567,621.06	€273,828,381.05

Expected Revenue	Market Penetration
€1M	0.37%
€5M	1.83%
€10M	3.65%

⁴² Appendix 8.7 – List of the companies

6.4 Interactive Prototyping

6.4.1 Questionnaire

The goal with this questionnaire was to investigate the phenomena and assumptions as mentioned already in 6.3.1 Assumptions. To be specific, the assumptions were that the companies from the list might feel certain administrative burdens when their employees go out to take tests. This assumption only makes sense if the company has a lot of employees and the testing is frequent. Then there is a possibility that the administration might spend a lot of resources scheduling people for tests. In that case, an on-site screening device might make sense to lower the burden.

Besides that, the employers have to compensate for the time the employees take to get tested, and with a large amount of employees taking the tests off-site, it might amount to a large sum of money. Here the assumption is that the companies might feel more comfortable spending money on reusable screening device that can be used on-site rather than having the employees all over the place getting tested "off-campus".

Lastly, the goal of the questionnaire was also to gather some information about how the companies handled the pandemic, and probably the most important question for the Interactive Prototyping was aimed at finding out the most desired features that would be expected to be included within the device. By finding the most desired features, the breathalyzer can be properly compared to the competitor's products which might lead to a discovery of gaps and strong focal points as well. The whole questionnaire can be found on this link: <https://forms.gle/tqK6GffRuN8rYrV6A>

6.4.2 Conducting the research

Conducting the research and actually sending out the forms have turned out to be more difficult than anticipated. Based on the previous experience, it usually takes a lot of time for companies to answer any type of email, especially when it's sent to the general email found on the website.

With that in mind, the task was to come up with a new creative way to send out the questionnaire to people inside the companies from the list. Fortunately, there is LinkedIn that has been developed with the purpose of connecting professionals together. LinkedIn also provides a great searching interface with a lot of filters. That made the search for the right people way easier since it allowed to filter by the country – Denmark and also companies – the list of 767 companies.

The only problem with sending the questionnaire to new people on LinkedIn is that if not connected already, too many requests sent might lead to a blocked account. Unfortunately, this was learned the hard way and resulted in a ban for an account of one of the team members. After learning about the algorithm, the decision was to use an automation tool for new connections called ProspectIn in order to send out the questionnaire with a short elevator pitch which was limited to a certain amount of letters. Here is an example of the message that has been sent automatically along with a connection request.

 **Boris Kacer** • 12:48 PM
Hi Claes, I represent a student group from SDU, currently working on a development of a COVID-19 screening device.

With that said, we have prepared a questionnaire: <https://forms.gle/3tmYoEAW5qUAmVLb6> where we would like you to share thoughts on the COVID-19 situation in your workplace.

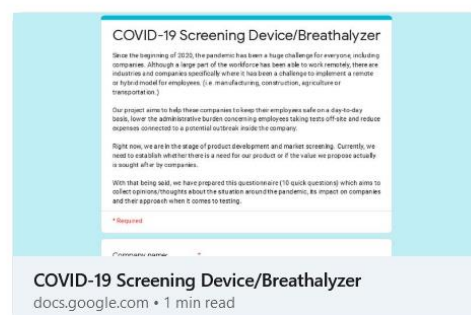

Figure 6.12 COVID-19 questionnaire post

The message had to include an explanation about who the team member is and what they represent. Next, fit the explanation of the questionnaire and the link to the questionnaire too. After the connection was made, there was a possibility to send another message with more deep explanation, however; this was not necessary in most cases because those who seen the message and responded also filled out the questionnaire.

6.4.3 Results

In order to get as many responses as possible, 1000 connection requests including the questionnaire link were sent out via the automation tool. Unfortunately, the response rate was extremely low and to date there were only 31 filled out questionnaires. That, however; did not mean that the responses were disregarded. On the opposite, the answers were fairly diverse and drew a solid picture about the COVID situation in some of the companies from the list.

The most important questions were on finding out whether employees would be up for an on-site testing, if they feel the off-site testing creates an administration burden, and lastly the question on the desired features.

8. If your company does not provide tests on-site, how would you feel about a screening device on-site in your workplace?

31 responses

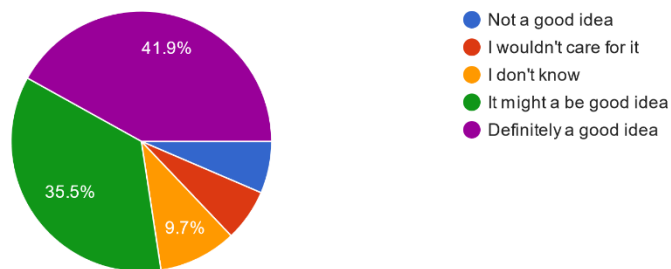

Figure 6.13 Questionnaire Q1

This question above provides a quite definitive conclusion where the bigger majority of the asked thinks that it would be "definitely a good idea" or "it might be a good idea".

6. If your company lets you get tested off-site, do you think that it creates a financial burden on the company to a certain degree? (i.e., company must ... get tested and substitute for missing employees)

31 responses

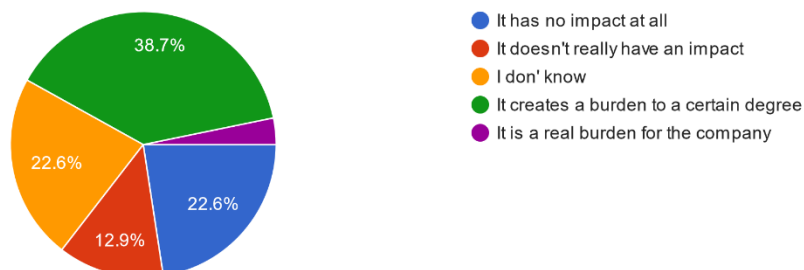

Figure 6.14 Questionnaire Q2

The next question about the burden did not provide one-sided results. Even though 38.7% of the asked thinks that it is a burden to a certain degree, the majority either doesn't know or thinks the opposite. After all, the people answering the questionnaire are workers and most of them have never thought about this or do not have any idea, which is completely understandable.

9. What are the features you would expect from such a screening device on-site? Please choose at most top 5.

31 responses

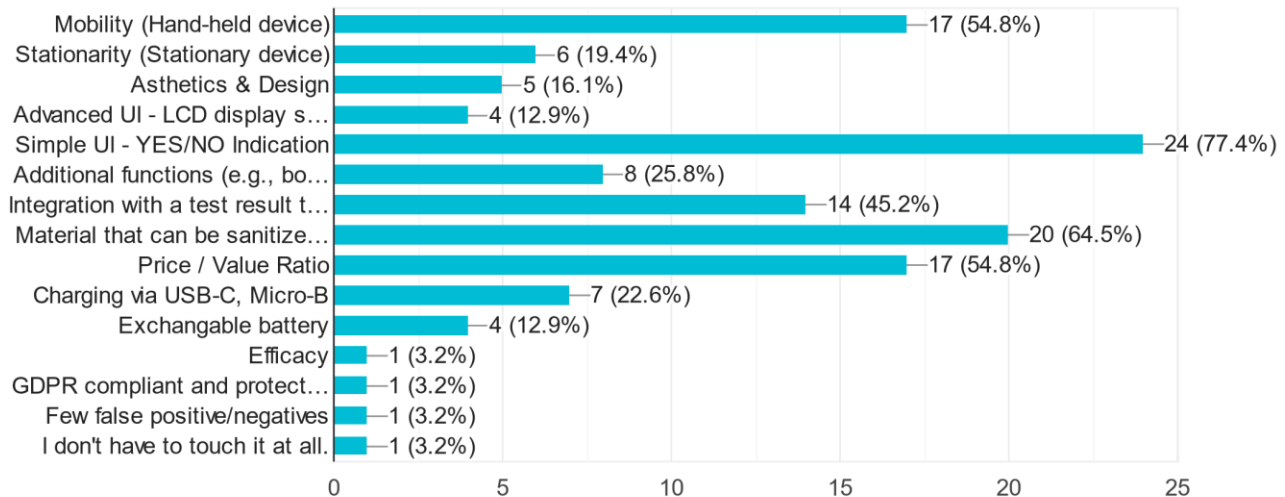

Figure 6.15 Questionnaire - Features

The last question concerned the features, and results turned out to be alluring. Most of the people voted for the mobility, simple UI, material that can be sanitized and price/value ratio. The price/value ration essentially means that the high price can be explained by the amount of value it could provide.

The conclusion on this questionnaire could be that some of the assumptions turned out to be true and some, like the question about the administrative burden, turned out to be just unclear. Nevertheless, it gave the team a lot of information to think about and consider.

The rest of the questions and answers can be found in the Appendix 8.8⁴³

6.4.4 Importance/Performance Matrix

Importance/Performance Matrix serves as a tool of comparison of the most important features in this case and their performance in comparison to the competition. The features used in the matrix are:

- **Mobility**
- **Simple UI – YES/NO indication**
- **Integration with a test result tracking system (e.g., website, mobile app)**
- **Material that can be sanitized easily**
- **Price / Value Ratio**

Another crucial thing is that the performance evaluation of each feature parallel to the competition is subjective and could differ if someone else were to perform it. This is just a small side note that relates to being critical.

⁴³ Appendix 8.8 - Questionnaire answers

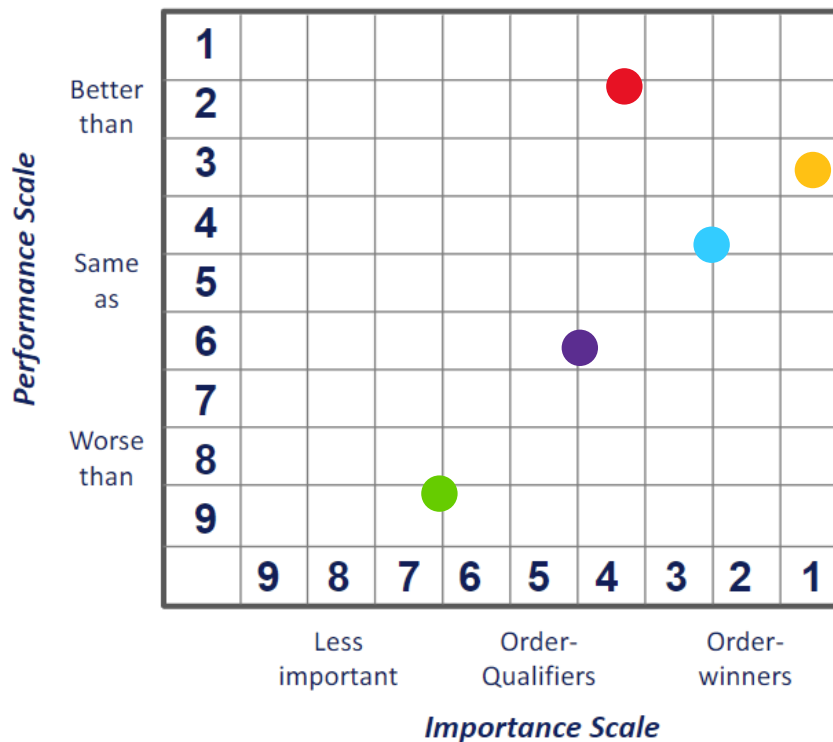

Figure 6.16 Importance/ Performance Matrix

The Importance scale is divided into 3 sectors – Less important, Order-qualifiers and Order-winners. What Less important features are speaks for itself, order-qualifiers are features that are extremely important and expected from the cusomters. Without them, the product is not able to compete with the other products. Order-winners are features that make the product stand out and provide a competitive edge.

A major order-winner for this breathalyzer is the Simple UI. It is a feature which performs better than the competition – whether it is Accula solution from TFS or Talis One from Talis Biomedical. All of these products’ user interface is more complicated than breathalyzer’s simple YES/NO indication by color. But that does not necessarily mean that the performance is the best.

Next, the mobility feature, where the breathalyzer outperforms all the competitors by far. Most of the competitors’s products are mobile, meaning they can be easily moved from place to place, however; they have to be stationary when the test analysis is performed.

Unsurprisingly, there are features where the breathalyzer perfoms with mediocrity. Those would be the price/value ratio and material that can be sanitized easily. These features are order-winners, thus expected by the potential customers. Therefore the mediocre performance is completely fine. The only thing to look out for is to keep up with any changes in the industry or changes in customer’s behaviour. It would be very dangerous to underperform on these features.

Lastly, the matrix has uncovered that the integration with a test result tracking system is something that is desired, however; not included in the breathalyzer. This is a feature that would need more attention if the product were to be launched on the market, in order to compete with competitors like Talis One by Talis Biomedical that provides a whole customizable software solution and integration with test docks.

7 Conclusion

7.1 Future Implementations

As the presented device is a prototype, multiple iterations and future implementations should be considered to create a product that is fully suitable for the medical market and fulfills customers' needs.

These are based on the market poll questionnaire, in which 31 companies have stated their expectations about the Breathalyzer. The most desired user features along with the ones which haven't been implemented into the device will be discussed below.

Injection molding manufacturing with a medical material

Material that can be sanitized at ease is placed as the 2nd most desired feature in the device (section 6.4.1 - Figure 6.15 Questionnaire - Features). Therefore, the current manufacturing method should be replaced with a more bulk production solution, that uses a medical grade, sanitizable material. Injection molding allows producing a smooth surface, high precision plastic elements in bulk. That would eliminate all warping and tolerance errors, making the device more sealed, aesthetic, and easier to sanitize. After developing a set of molds and choosing the appropriate material the Breathalyzer would be ready for mass production.

Fully hermetic sealing & safety

A few implementations are possible to obtain a complete seal of the device and prevent particles from spreading to the outside. Although the current design provides decent sealing due to its geometry, it could be further iterated. Firstly, rubber seals could be used in particularly exposed areas, meaning for example the cartage opening closed with a slide cover. Sealing of the device could be generally reinforced by applying a medical grade sealant in the connection areas between parts.

Regarding the two vent filters, as mentioned in the mechanical section, for the prototype pieces of surgical masks were used. Eventually, these should be replaced with a similar medical filter solution, that would be easily replaceable. The top ventilation filter would finally be built as a small cartridge that would provide a tight fitting on the exhaust vent.

Rechargeable battery pack + Charging via USB

As discovered in the questionnaire, rechargeability is more desirable than simple battery exchange, as it becomes a standard in modern electronics. The 4 AA battery power supply could easily be replaced with a corresponding rechargeable battery pack, with a micro-USB/ USB C socket integrated into the battery compartment (base).

Test result system & additional features

Integration with a test result system (website or app) is listed as one of the most desired features by potential users. That way an employer could have a full inside into the test results, what time and how many tests have been conducted etc.

Using a current set up a Bluetooth/Wi-Fi module could be added to automatically synchronize the results in real-time and store them on a website or a mobile app depending on the communication channel chosen. As an Arduino based board is used it would be fairly simple to program a data transmitting protocol with an excel sheet, website or mobile app. Alternatively, the device could store a certain amount of test data in its memory, which can later be transferred through a USB cable to a computer.

On top of the result system integration, additional measurements can be implemented into the device. For example, with a body temperature sensor, the stored result could consist of both the Covid-19 test and the user temperature. Eventually, a forehead temperature scanner could be placed on the front side of the device above the nozzle. The measurements would be taken either simultaneously or separately, by implementing an additional button (for temperature trigger or a function change).

Selection of cartridges for a variety of diseases

The current coating solution bounds ethanal present in COVID-19 infected person's breath. Potentially other types of chemical solutions could be developed to bound other gases, indicate different diseases. The developed cartage and the piezoelectric membrane can work with any kind of coating. Since the measurement is based on a change in the resonance frequency, the type of coating does not impact the concept of the device. The coating can bound different molecules which will change the resonance frequency of the membrane, and give a detected/ non-detected binary result.

Minimized PCB design

In the prototype, the electronics consist of a Veroboard with soldered components combined with a PCB. Ultimately, the design would be minimalized to fit on a small PCB board, having all the necessary components. Consequently, the case design could potentially be reduced in size resulting in an even more mobile design.

7.2 Summary

Multiple difficulties have been experienced during the 6 months project period. That meant usually various delays due to delivery, component mis-selection, miscommunication, etc. Ultimately, the device was manufactured successfully fulfilling all the criteria. The market research, including interactive prototyping (questionnaire), identified needs in the market. Over 85% of the interviewees stated that a mobile screening device is either a "Definitely good idea" or "Might be a good idea". The device meets most of the user expectations: having a simple UI, being mobile, easy to sanitize. The selected technology can deliver the objectives, meaning that the proof of concept was delivered. The team has developed a method for measuring the resonance frequency change in the piezoelectric membrane. The final prototype is simple to operate and re-use. The design is aesthetic, ready for future implementations and bulk production. On top of the main requirements, the COVID-19 coating itself was enhanced, allowing a more effective molecule bounding.

Breathalyzer brings an incredible value for its price, possibly reducing the financial, administrative, and time burden for the companies. In addition, through its reusability, the device reduces plastic waste, helping to revert the rapid increase of plastic use in the medical sector. This project also constitutes solid proof of concepts and another use of the emerging so-called "e-nose" technology based on molecular weighting. A lot of applications based on those technologies are expected to appear in the next decade.

Depending on the marketing, further implementations, and product development, the Breathalyzer might potentially be a strong competitor to the COVID-19 rapid tests, as well as become an innovative detection device for other gas molecules and diseases.

8 Appendix

8.1 Work Breakdown structure

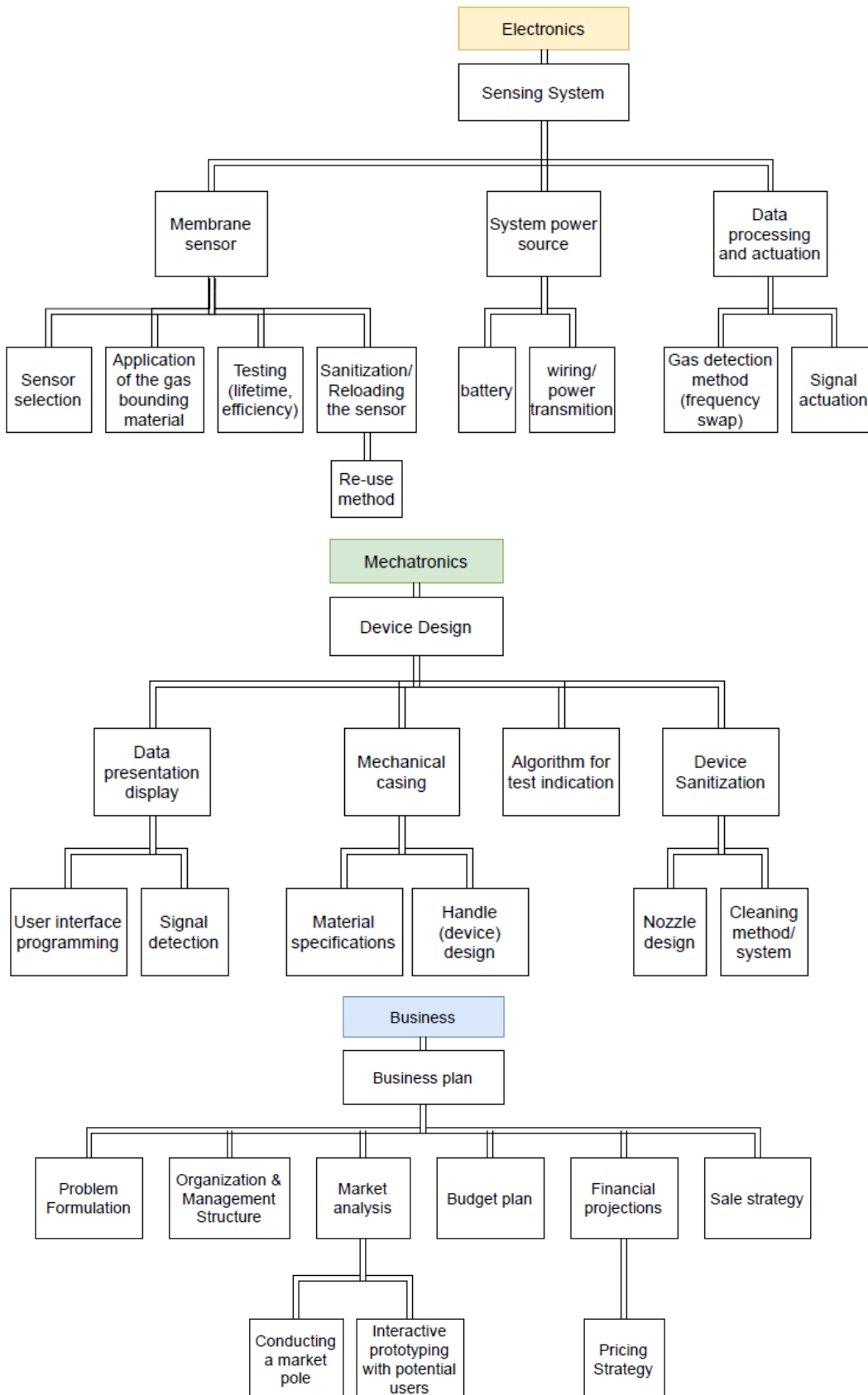

8.2 Activity Node Network

Early Start	Early Finish	ID	Description	Late Start	Late Finish	Duration
-------------	--------------	----	-------------	------------	-------------	----------

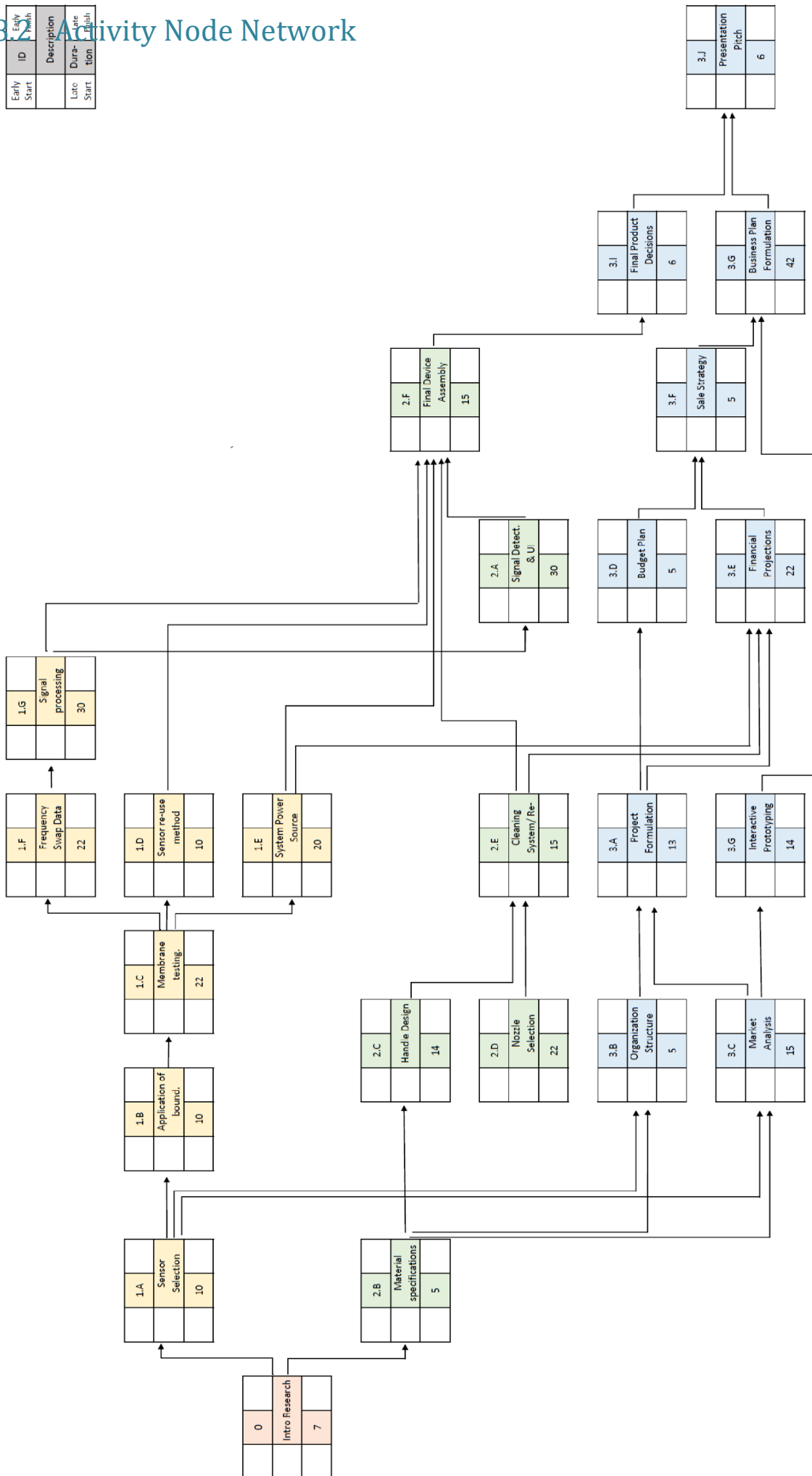

8.3 Gantt Chart

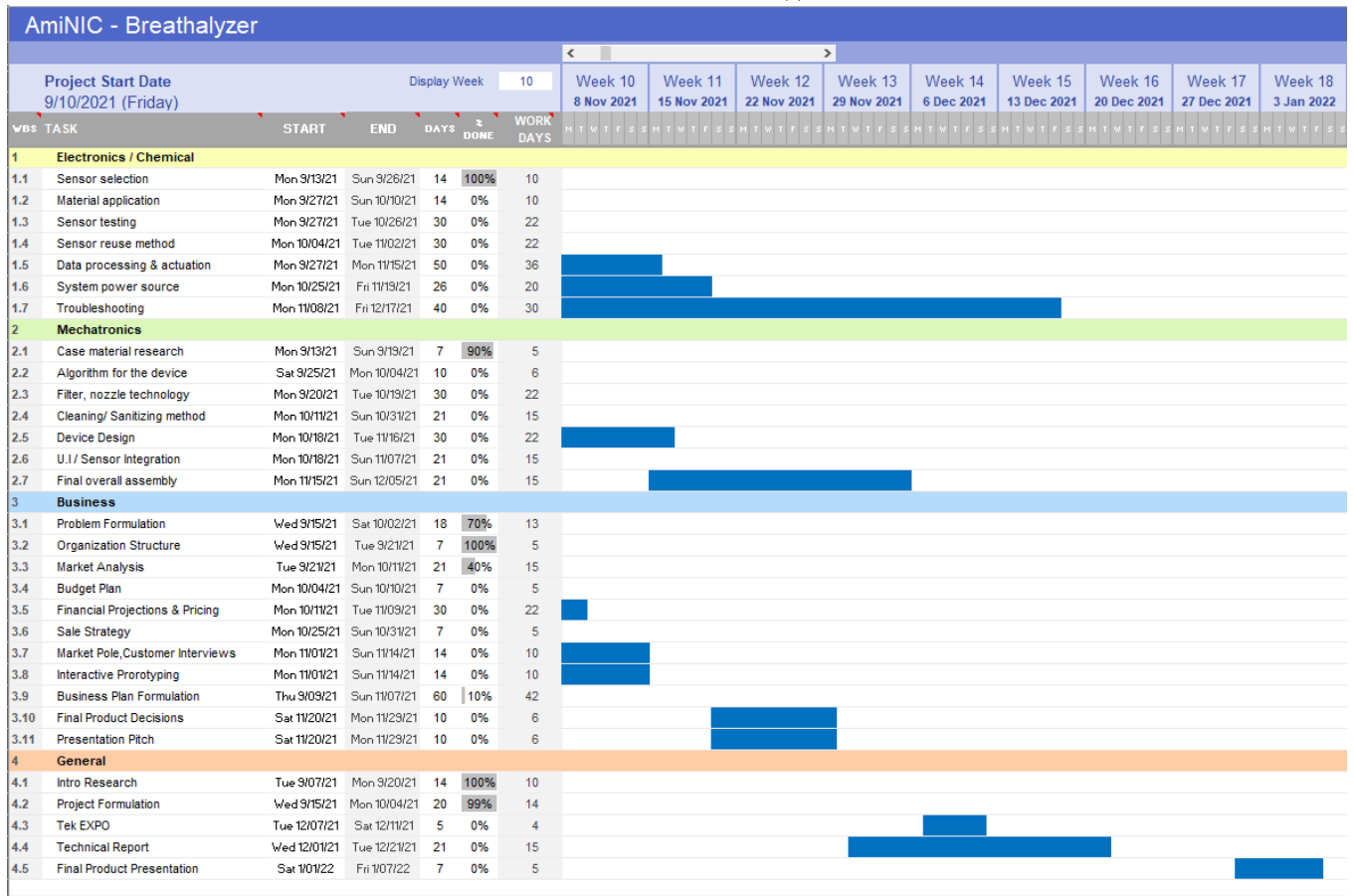
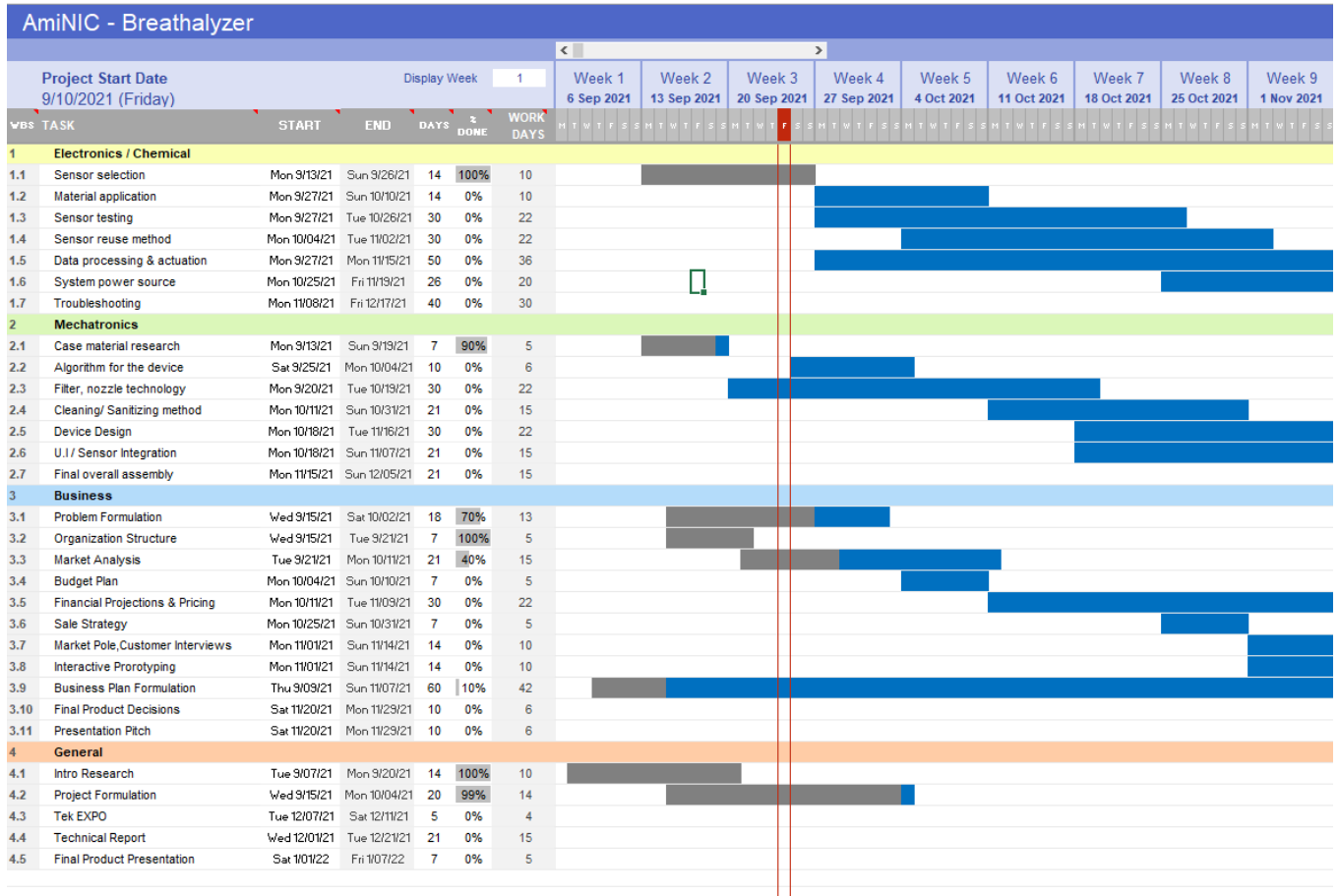

8.4 Risk Response Matrix

Risk Event	Response Strategy	Contingency Plan	Trigger	Responsible
Technology is not able to deliver set requirements	Migrate: Due to a limited expertise, validate each choice with the supervisors/ experienced engineers. Test each part asap.	Order new components and conduct imitate testing to validate further choices.	-membrane does not bound the gas (sensor can't detect Covid-19) - unsuccessful data processing from the sensor	Mechatronics, Electronics Team
Device too advanced to achieve mobility	Migrate: Every new development must be reviewed in regards to the scope and project requirements.	Try to redesign the handle, resize the parts, come up with alternative solutions	-the "handy" design does not fit all the developed features and elements	Mechatronics, Electronics Teams
Unwanted complexity	Migrate: Every new development must be reviewed in regards to the scope and project requirements.	Try to redesign the handle, eliminate non-essential parts, come up with alternative solutions	-unnecessary features are added that have no functional impact	Mechatronics, Electronics Teams
Unreliable operation	Migrate: Staying critical, monitoring the progress and clearly reasoning all decisions, testing the device each step.	Troubleshoot, review the design decisions, reprogram, debug the software, ask for feedback from experienced engineers	-the device requires a lot of effort and time	Mechatronics, Electronics, Innovation & Business Teams
Device not suitable for the market	Migrate: Every new development must be reviewed in regards to the scope and project requirements. Conduct user testing.	Try to find alternative parts (pricing options), come up with an alternative product design.	-not satisfying the customer's needs, unfeasible production due to cost	Innovation & Business Teams
Budget overrun	Migrate: Constantly monitor and document the progress, tasks and expenses.	Try to find alternative parts (pricing options).	-exceeding the 10 000kr initial project budget limit	Project managers
Project delivery time overrun	Migrate: Constantly monitor and document the progress, tasks and expenses.	Try to speed-finish the project in a few days. Focus on proper documentation and research other than final physical device.	-project isn't finished, no physical product on the 17th December	Project managers
Communication issues	Migrate: Clear project plan and an involved team. Staying respectful to teammates.	Solve conflicts in a calm mature way, listen and	-conflicts within the group, work delays due to miscommunication	Project managers

8.5 Battery Performance Graph

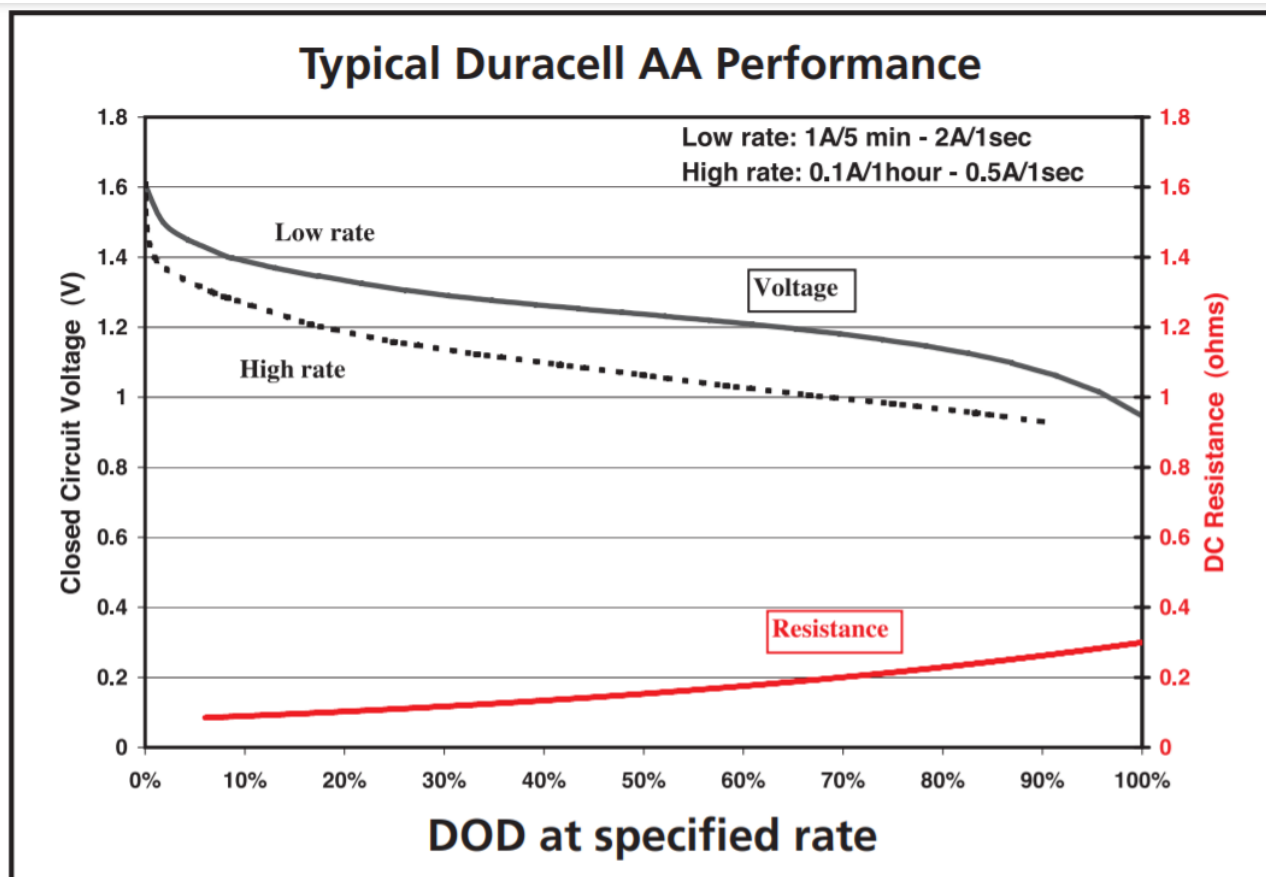

8.6 Reaction mechanism between methyl red and aldehyde.

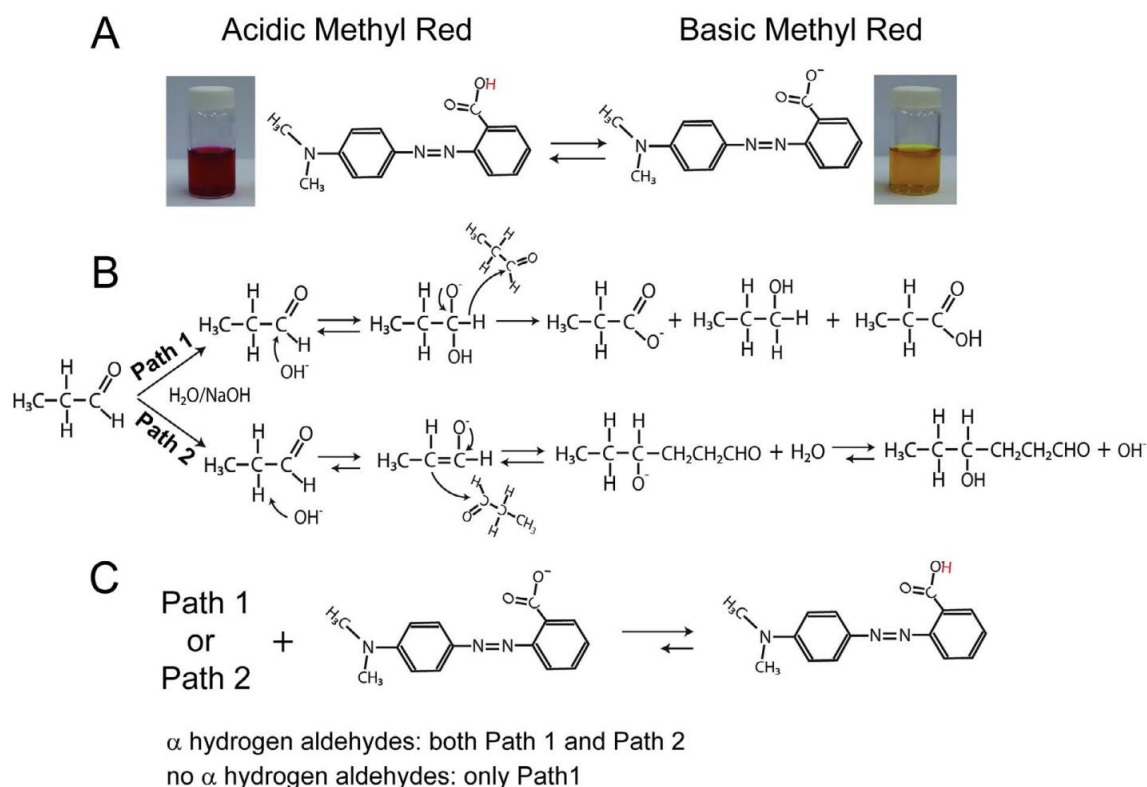
Scheme 1. A) Structure of acidic and basic Methyl Red. B) Chemical reactions with aldehyde and concentrated OH^- . C) Proposed reaction mechanism between aldehyde and the sensor.

8.7 Chemical risk assesment.

Chemical Risk Assessment										
Name	Blaser Arthur	Substitution considerations [Can the substances be substituted for some less hazardous ones?]								
Date	10/11/2021	Examinations regarding occupational medicine? [Are relevant examinations of own employees accessible?]								
Latest update (date)		Signature from the department's working environment group (see guidelines):								
Chemical quality check, name and date	[To be filled in by the chemist in charge, see guidelines]									
Risk Assessment regarding	Ethanal binder solution									
Institute / Department	MC/Mansard									
Building	Block A									
Room (No. + description)	Chemistry Laboratory									
Exposure (extent, type and duration)										
Exposure - inhalation										
Exposure - skin contact										
Exposure - ingestion										
Procedure	Name of substance and CAS no. - and quantities	Symbols	Symbol descriptions	Other hazards	Remedies/Prevention	Protective equipment	At accidents and spillage	Threshold limit values	Waste management	Storage
Ethanal (acetaldehyde) binder solution is a selective receptor applied on top surface of electro-mechanic sensors. The binder solution contain: - Methyl Alcohol: 10ml - Water: 10ml - Methyl red: 0.40g - Methyl red sodium salt: 0.350 g - Sodium Hydroxide (NaOH): 2.5g All substance are mixed together until obtaining a dissolved solution.	CAS no. 37-59-1 Name: Methyl Alcohol	 	R225: Highly flammable liquid and vapour. H301+311+331: Toxic if swallowed, in contact with skin or if inhaled. H370: Causes damage to organs. P210: Keep away from ignition sources. No smoking. P280: Wear protective gloves/eye protection. P301+310: IF SWALLOWED: Immediately call a POISON CENTER/doctor. P303+361+353: IF ON SKIN (or hair): Take off immediately all contaminated clothing. Rinse skin with water/shower. P304+340+310: IF INHALED: Remove victim to fresh air and keep at rest in a position comfortable for breathing. Immediately call a POISON CENTER or doctor/physician.		Inhalation: The person should be taken into the fresh air, kept quiet and under supervision. If there is a risk of loss of consciousness the person should be placed in the recovery position and kept warm. If the person stops breathing, artificial respiration should be given. Skin: Rinse thoroughly with water, remove contaminated clothing and any jewellery. Eyes: Rinse immediately with water. Hold the eye wide open. Remove contact lenses. Continue to rinse with water until treatment is taken over by doctors. If swallowed: Immediately rinse the mouth out and drink water or milk. Do not give liquids to the unconscious. Do not cause vomiting. If discomfort persists consult a doctor, taking along these instructions. Burns: Rinse immediately with water and continue until pain disappears. While rinsing with water, remove clothing which is not burnt on the skin. Go to emergency department at nearest hospital and continue to rinse with water en route.	 	Evacuate the area as necessary. Switch off all apparatus. Prevent further spreading and ventilate the area. Avoid contact with the substance. If appropriate, use gloves and breathing equipment with a combination filter (Type ABCE-P). Soak up any spillages with vermiculite or sand and discard as chemical waste. Clean the area after clearing up the spillage. Inform the municipal authorities and those responsible for the environment in the workplace of any major discharge into the surroundings.	Threshold Limit Value (TLV, mg/m ³): 200 ppm CMR Threshold Limit Value (TLV, ppm): 200 ppm Note according to RT (O,K,H,L,S) H, O Vapour Hazard index (VHDI)RE: 150 Derived No Effect Level (DNEL) Lethal Dose (LD50) (Oral, Rat) Lethal Dose (LD50) (Oral, Rat) Lethal Concentration (LC50) 3.1 mg/L (inhal4H; Rat)	Waste group: C Class: 3 Class Code: FT1 PGII EN no. 1230	Must be stored tightly sealed in a well-ventilated refrigerator, under argon. Store in Chemical Cabinet 3

Extract of chemical risk assessment available upon request to group members.

8.8 Teensy code

/*Code for controllingthe teensy, includes:

```
* Frquency generator, connexion with the arduino for the SPI and set up
* SD memory save in teenst
* FFT
*/
```

```
/*
** Gene_start pin 1
** gene_reset pin 2
** Red LED pin 15 (A1)
** Yellow LED pin 16 (A2)
** Green LED pin 17 (A3)
** Trigger button 18 (A4)
** Read ADC0 PIN 14 (A0)
** Diff Channel 0 Positive PIN 24 (A10) not necessary to sold anything
**Diff channel 0 Negative PIN 25 (A11) not necessary to sold anything
*/
```

```
#include <ADC.h>///
#include <ADC_util.h>
#include <SD.h>///For save in microSD
#include <SPI.h>
#include <ArxContainer.h>
#include "arduinoFFT.h"
```

```
#define CHANNEL A0
#define SCL_INDEX 0x00
#define SCL_TIME 0x01
#define SCL_FREQUENCY 0x02
#define SCL_PLOT 0x03
```

```
std::vector<int> list;
```

```
arduinoFFT FFT = arduinoFFT(); /* Create FFT object */
```

```

const int chipSelect = BUILTIN_SDCARD;
const int readPin = A0; // ADC0

ADC *adc = new ADC(); // adc object

//For controlling the arduino with two analog ports as output
const int gene_start = 1;
const int gene_reset = 2;

//LED and buttons
const int redLED_Pin =15;
const int yellowLED_Pin =16;
const int greenLED_Pin =17;
const int button_Pin =18;

int buttonState=0;

//c is used for the serial communication input
char c=0;
File dataFile;

int sweep_value=0;
const unsigned int time_analog_out=10;
const unsigned int sampleNumber=32000;
const unsigned int number_of_loops =1; //Max number=3, if we need to to the sweep
more than one time for better resolution
const uint16_t samples = 16384;; //This value MUST ALWAYS be a power of 2, could
be possible to change to unsigned int samples = 131072
const double samplingFrequency = 892000; //Hz, must be less than 1.000.000 due to
teensy ADC
const unsigned int frequency_shift=100000;//The frequency that needs to be change
the response for being consider positive in COVID
double peakFrequency1=0;
double peakFrequency2=0;
double difference_peak=0;
const unsigned int total_number=number_of_loops*sampleNumber;

unsigned int sampling_period_us;
unsigned long microseconds;

double vReal[samples];
double vImag[samples];

int index_SD = 0;
int array_SD[number_of_loops*sampleNumber];

void setup() {

  pinMode(LED_BUILTIN, OUTPUT);
  pinMode(readPin, INPUT);

  pinMode(A10, INPUT); //Diff Channel 0 Positive
  pinMode(A11, INPUT); //Diff Channel 0 Negative

  Serial.begin(9600);

  /////// ADC0 /////
  // reference can be ADC_REFERENCE::REF_3V3, ADC_REFERENCE::REF_1V2 (not for
  Teensy LC) or ADC_REFERENCE::REF_EXT.
  //adc->adc0->setReference(ADC_REFERENCE::REF_1V2); // change all 3.3 to 1.2
  if you change the reference to 1V2
  Serial.println("Begin setup");

```

```

adc->adc0->setAveraging(1); // set number of averages
adc->adc0->setResolution(16); // set bits of resolution

// it can be any of the ADC_CONVERSION_SPEED enum: VERY_LOW_SPEED, LOW_SPEED,
MED_SPEED, HIGH_SPEED_16BITS, HIGH_SPEED or VERY_HIGH_SPEED
// see the documentation for more information
// where the numbers are the frequency of the ADC clock in MHz and are
independent on the bus speed.
adc->adc0->setConversionSpeed(ADC_CONVERSION_SPEED::VERY_HIGH_SPEED); //
change the conversion speed
// it can be any of the ADC_MED_SPEED enum: VERY_LOW_SPEED, LOW_SPEED,
MED_SPEED, HIGH_SPEED or VERY_HIGH_SPEED
adc->adc0->setSamplingSpeed(ADC_SAMPLING_SPEED::VERY_HIGH_SPEED); // change
the sampling speed

// always call the compare functions after changing the resolution!
//adc->adc0->enableCompare(1.0/3.3*adc->getMaxValue(), 0); // measurement
will be ready if value < 1.0V
//adc->adc0->enableCompareRange(1.0*adc->adc0->getMaxValue()/3.3, 2.0*adc-
>adc0->getMaxValue()/3.3, 0, 1); // ready if value lies out of [1.0,2.0] V22
// If you enable interrupts, notice that the isr will read the result, so
that isComplete() will return false (most of the time)
adc->adc0->enableInterrupts(adc0_isr);

adc->adc0->startContinuous(readPin);

Serial.print("Initializing SD card...");

// see if the card is present and can be initialized:te
if (!SD.begin(chipSelect)) {
  Serial.println("Card failed, or not present");
  while (1) {
    // No SD card, so don't do anything more - stay stuck here
  }
}
Serial.println("card initialized.");
pinMode(gene_start,OUTPUT);
pinMode(gene_reset,OUTPUT);

digitalWrite (gene_start, LOW);
digitalWrite (gene_reset, LOW);

//Define LED as outputs and button as input
pinMode (redLED_Pin, OUTPUT);
pinMode (yellowLED_Pin, OUTPUT);
pinMode (greenLED_Pin, OUTPUT);
pinMode (button_Pin, INPUT);

//For the FFT
sampling_period_us = round(1000000*(1.0/samplingFrequency));

delay(100);
}

void loop() {

  SD_remove();
  //light up the three LED
  three_LED_on();
}

```

```

while (!digitalRead(button_Pin)){

delay(1000);

for (int i=0;i<number_of_loops;i++){
  //Save all the samples in the flash memory
  sample_data(i);
  SD_save();
  //Reset sweep
  sweep_reset();
  delay(100);
}

//Print errors, if any.
ADC_error();

//Close SD card
SD_close();

//SD read for the FFT
SD_read();

//Now is going the FFT and save in memoy the peak
peakFrequency1=FFT_peak();

SD_remove();
delay(1000);

three_LED_off();
yellow_LED_on();
//Now the patient can blow and after we push the button

while (!digitalRead(button_Pin)){

  delay(1000);

  for (int i=0;i<number_of_loops;i++){
    //Save all the samples in the flash memory
    sample_data(i);
    //Save the data in the SD card, Comment if it is not necessary
    SD_save();
    //Reset sweep
    sweep_reset();
    //SD read for the FFT
    SD_read();
    delay(100);
  }

  //Close SD file
  SD_close();

  //Print errors, if any.
  ADC_error();

  //SD read for the FFT
  SD_read();

  //Now is going the FFT and save in memoy the peak
  peakFrequency2=FFT_peak();

  //Compare both results and decide if it's positive orr negative (more research)
  delay(1000);

```

```

yellow_LED_off();

difference_peak=peakFrequency2-peakFrequency1;

Serial.print("Peak Frequency 1:      ");
Serial.println(peakFrequency1);
Serial.print("Peak Frequency 2:      ");
Serial.println(peakFrequency2);
Serial.print("difference_peak:      ");
Serial.println(difference_peak);

if (difference_peak<0){
  difference_peak=-difference_peak;
}
//Check the if statement after more tests
if(difference_peak<frequency_shift){//No COVID
  Serial.println("No COVID, green LED");
  green_LED_on();
}
else if(difference_peak>frequency_shift){//COVID
  Serial.println("COVID, red LED");
  red_LED_on();
}
delay(1000);

while (!digitalRead(button_Pin));
delay(1000);
}

void adc0_isr(void) {
  adc->adc0->analogReadContinuous();
  digitalWriteFast(LED_BUILTIN, !digitalReadFast(LED_BUILTIN)); // Toggle the
led
}

void sample_data(unsigned int loop_number){

  list.erase(list.begin(),list.end());//we delete all the values in the
flash memory
  int multiple=loop_number-1;
  //We start the sweep with the communication with the arduino
  sweep_start();
  if (loop_number>1){
    delayMicroseconds((multiple*sampleNumber));
  }

  for (unsigned int i=0; i<sampleNumber;i++){
    sweep_value = (uint16_t)adc->adc0->analogReadContinuous(); // the
unsigned is necessary for 16 bits, otherwise values larger than 3.3/2 V are
negative!
    list.push_back(sweep_value);
    delayMicroseconds(1);
  }
}

void sweep_start(void){
  digitalWrite (gene_start, HIGH);
  delayMicroseconds(time_analog_out);
  digitalWrite (gene_start, LOW);
}

```

```

}

void SD_save(void) {
  SD_close();
  dataFile = SD.open("datalog.txt", FILE_WRITE);
  for (unsigned int i=0; i<sampleNumber;i++){
    sweep_value=list[i];
    dataFile.println(sweep_value);
  }
  SD_close();
  delay(10);
}

void sweep_reset(void) {
  digitalWrite (gene_reset, HIGH);
  delay(100);
  digitalWrite (gene_reset, LOW);
}

//Function that create the files that are going to be save in the SD memory
void SD_open(void) {
  File dataFile = SD.open("datalog.txt", FILE_WRITE);
}

void SD_close(void) {
  dataFile.close();
}

void SD_remove(void) {
  SD.remove("datalog.txt");
}

void SD_read(void) {

  dataFile = SD.open("datalog.txt");

  // READ FROM CARD
  if (dataFile){
    for (index_SD=0;index_SD<total_number;index_SD++){
      int input=dataFile.parseInt();
      array_SD[index_SD]=input;
    }
  }
  SD_close();
}

void ADC_error(void) {
  // Print errors, if any.
  if(adc->adc0->fail_flag != ADC_ERROR::CLEAR) {
    Serial.print("ADC0: ");
    Serial.println(getStringADCErrror(adc->adc0->fail_flag));
  }
}

void three_LED_on(void) {
  digitalWrite(redLED_Pin,HIGH);
  digitalWrite(yellowLED_Pin,HIGH);
  digitalWrite(greenLED_Pin,HIGH);
}

```

```

void three_LED_off(void) {
    digitalWrite(redLED_Pin,LOW);
    digitalWrite(yellowLED_Pin,LOW);
    digitalWrite(greenLED_Pin,LOW);
}

void green_LED_on(void) {
    digitalWrite(greenLED_Pin,HIGH);
}

void green_LED_off(void) {
    digitalWrite(greenLED_Pin,LOW);
}

void yellow_LED_on(void) {
    digitalWrite(yellowLED_Pin,HIGH);
}

void yellow_LED_off(void) {
    digitalWrite(yellowLED_Pin,LOW);
}

void red_LED_on(void) {
    digitalWrite(redLED_Pin,HIGH);
}

void red_LED_off(void) {
    digitalWrite(redLED_Pin,LOW);
}

double FFT_peak (void) {
    /*SAMPLING*/
    microseconds = micros();
    for(int i=0; i<samples; i++)
    {
        vReal[i] = array_SD[i];
        vImag[i] = 0;
        while(micros() - microseconds < sampling_period_us){
            //empty loop
        }
        microseconds += sampling_period_us;
    }
    /* Print the results of the sampling according to time */
    //Serial.println("Data:");
    //PrintVector(vReal, samples, SCL_TIME);
    FFT.Windowing(vReal, samples, FFT_WIN_TYP_HAMMING, FFT_FORWARD); /* Weigh data
    FFT.Compute(vReal, vImag, samples, FFT_FORWARD); /* Compute FFT */
    FFT.ComplexToMagnitude(vReal, vImag, samples); /* Compute magnitudes */
    double x = FFT.MajorPeak(vReal, samples, samplingFrequency);
    return x;
}

```

8.9 List of the companies



List of companies -
Results.pdf

8.10 Questionnaire answers

1. How has your company been affected by COVID-19

31 responses

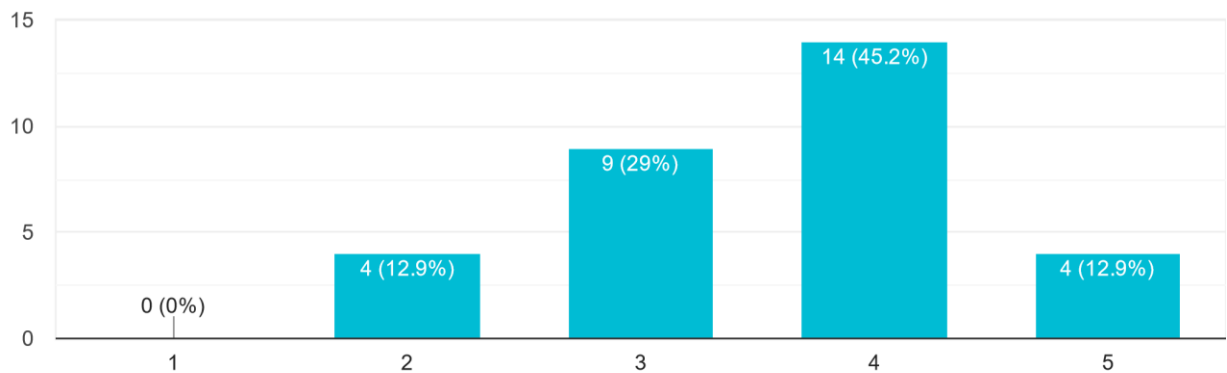

2. What are the consequences if an employees get tested positive at your workplace?

31 responses

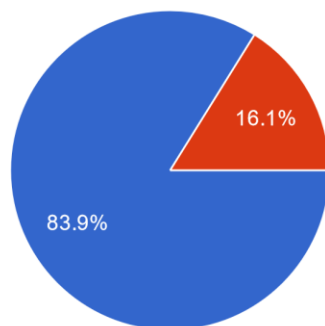

- Infected employee and people they have met with in the workplace have to stay home
- Partial shutdown, the whole department gets shutdown and stay at home
- Complete shutdown, the whole workplace needs to isolate

3. Does your company require employees to get tested regularly?

31 responses

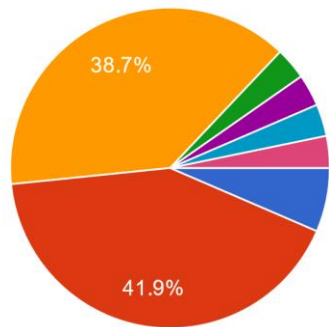

- Yes, it's mandatory
- Yes if not vaccinated
- No, it's not mandatory
- only none vaccinated needs regular testing
- Yes, mandatory if not vaccinated.
- No, but it is highly recommended
- Mandatory from next year

4. Do employees at your company mainly get tested at

31 responses

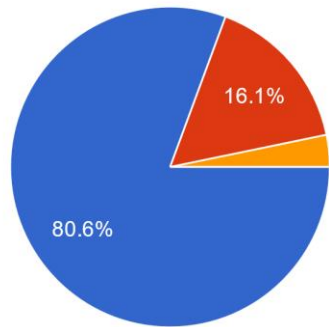

- Testing centers
- On-site tests (at your workplace)
- Depends on your position and time period. They did test on site but now they dont anymore.

5. Given employees get tested at a test center (off-site), they do so

31 responses

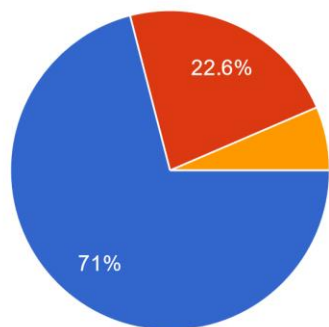

- On their own time
- During work hours
- Company provides tests on-site

6. If your company lets you get tested off-site, do you think that it creates a financial burden on the company to a certain degree? (i.e., company must ... get tested and substitute for missing employees)

31 responses

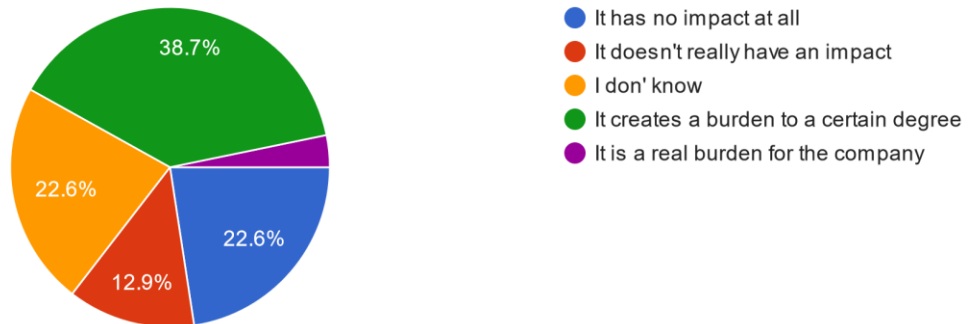

7. If your company provides tests on-site, do you think it is a benefit?

31 responses

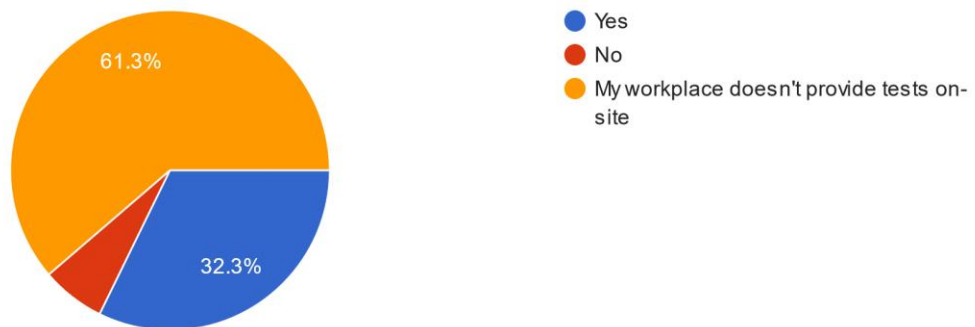

8. If your company does not provide tests on-site, how would you feel about a screening device on-site in your workplace?

31 responses

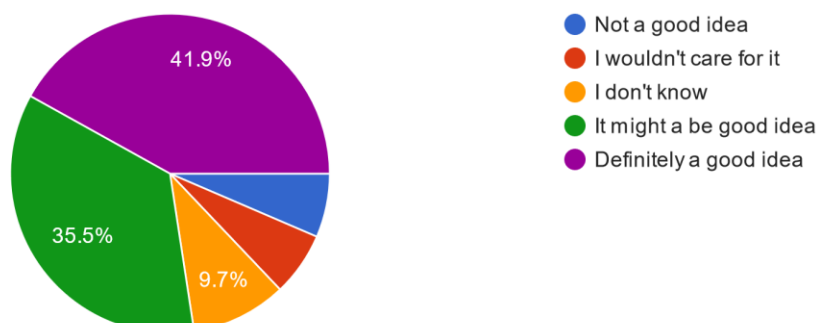

9. What are the features you would expect from such a screening device on-site? Please choose at most top 5.

31 responses

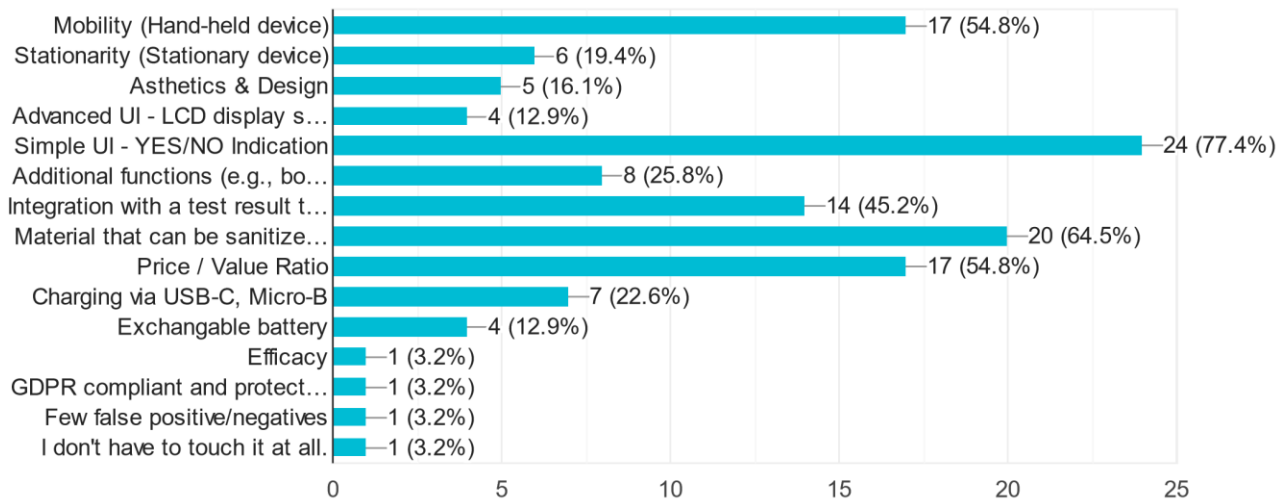

10. Financially speaking, do you think your company would be interested in this device if it was a one-time purchase in a range of 1000-3000 EUR + f...ing the cartridges after certain amount of time?

30 responses

