

DUAL Ports

De-carbonising port business today

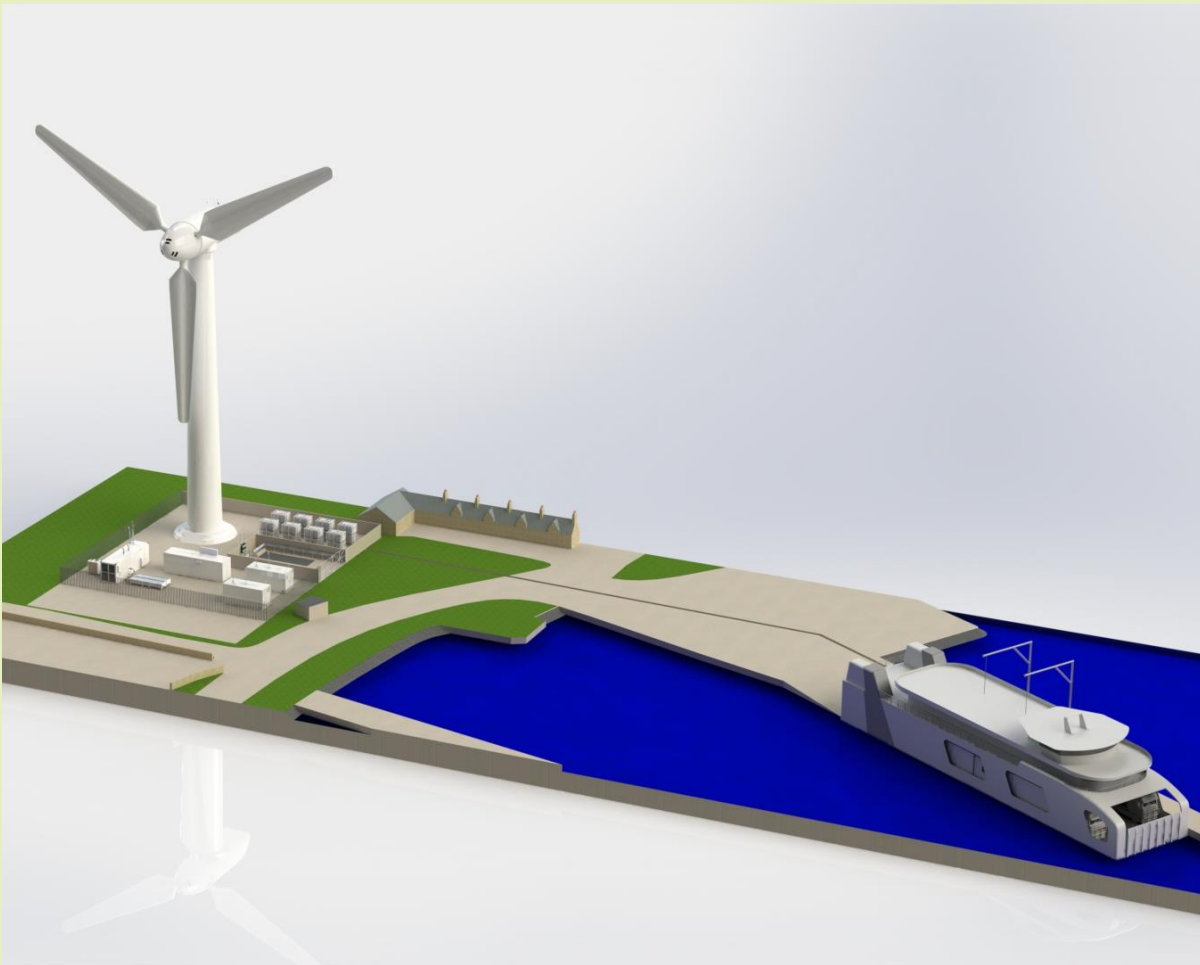

Feasibility of Hydrogen Bunkering



Dr Kris Hyde and Dr Andrew Ellis

ITM Power

30/01/2019



DUAL Ports

De-carbonising port business today

Executive Summary

As society and policy makers become increasingly concerned with greenhouse gases and air pollution, shipping emissions are attracting attention. Hydrogen is considered by many as a potential clean fuel for vessels with its ease of production from renewable electricity, however, it is a fuel with which the maritime industry has little experience.

ITM Power (ITM) was asked to compare the safety case for hydrogen, design a hydrogen bunkering system and consider the business case of two applications for that system.

ITM is a global leader in the design and manufacture of rapid response PEM electrolyser systems that produce hydrogen using renewable energy to split water. As part of its effort to develop the market in transport, the company has pioneered the roll-out of a network of hydrogen refuelling stations, for a variety of mobility options.

As part of this study, ITM have considered the generality of hydrogen as a fuel – how it can be consumed and stored on the vessel and the implications these choices would have on the required bunking system.

A safety comparison was undertaken between LNG and liquefied hydrogen (LH₂). It was concluded that due to the large quantities of stored energy, both these fuels potentially present a significant hazard, and require careful engineering controls. The differences in safety between the fuels is minimal, with hydrogen probably being safer if stored outdoors, and LNG probably safer if stored indoors.

It was concluded that hydrogen is a viable fuel, with liquefied hydrogen being the preferred storage method. At present, there is insufficient liquefied hydrogen production available in Europe, and while this will change in the long-term, in the short-term, gaseous hydrogen is likely to be the most prevalent. This view was reinforced when it was confirmed that the Orkney Islands are likely to be receiving a gaseous hydrogen ferry for deployment in the near future.

Gaseous hydrogen was therefore taken forwards for consideration in this bunkering system feasibility study.

It was concluded what whilst the basic components for a bunkering systems are set, their configuration will change depending on the specifics of each customer. Thus, an approach was taken to design a modular and scalable system that could be readily adapted. The details of each module are provided.

A general design was applied to the specific case of Orkney, where the DUAL Ports hydrogen pilot is focussed. This is a slightly unusual 'customer' as considerable hydrogen infrastructure is already in place and in some scenarios hydrogen is generated and used on different islands. Four options for hydrogen production and bunkering were considered based on considerable modelling of the electricity generation from wind, the storage required to achieve an assumed 99% availability, along with the electrolysis generation process. For each scenario, the equipment was fully specified and costed.

DUAL Ports

De-carbonising port business today

Four scenarios were taken forwards for business case modelling. For each, the CAPEX, OPEX, income etc. were considered in detail and the resulting cash flow calculated. It was concluded that the most promising was the establishment of a new hydrogen generation site in Balfour, Shapinsay, which could supply hydrogen at 350 bar directly into the ferry in Shapinsay Harbour. However, even this scenario results in a gaseous hydrogen price that will exceed the equivalent diesel cost level. This may require an acceptance that for small scale bunkering projects, zero carbon fuels are more expensive than diesel, or a relaxation on the assumed 99% availability of the zero carbon fuel.



DUAL Ports

De-carbonising port business today

Table of Contents

1	Background to Project.....	7
2	Selection of Hydrogen Bunkering Technology.....	9
2.1	General Considerations of Hydrogen Vessels and Refuelling	9
2.1.1	Method of Vessel Converting Fuel to Power	9
2.1.2	Method of Storing Hydrogen	10
2.1.3	Method of Bunkering Hydrogen	13
2.1.4	Hydrogen Generation	14
2.2	Identification of Preferred Options.....	15
2.2.1	Option 1: LH ₂	17
2.2.2	Option 2: LOHC.....	18
2.2.3	Option 3: Metal Hydride	18
2.2.4	Option 4: Gaseous H ₂	18
2.3	Option taken forward for Detailed Design.....	19
3	Comparison between Safety of Hydrogen and LNG	20
3.1	Introduction to Safety of hydrogen and LNG	20
3.2	Discussion of Safety Data	23
3.2.1	Comparing Gaseous Hydrogen and Natural Gas	23
3.2.2	Comparing LH ₂ and LNG.....	24
3.3	Conclusion of Safety Comparison between Hydrogen and Natural Gas	24
4	Detailed Design of Gaseous Hydrogen Bunkering System	25
4.1	Background.....	25
4.2	Design Outline	25
4.3	Design Compliance	26
4.4	System Components.....	27
4.4.1	Power Connection.....	27
4.4.2	Power Supply Module.....	27
4.4.3	Electrolyser Module	29
4.4.4	Low Pressure Buffer Tank	35
4.4.5	Compression	37
4.4.6	High Pressure Storage	39
4.4.7	Dispenser.....	40



DUAL Ports

De-carbonising port business today

4.5	Tube Trailer Connection Point.....	42
4.5.1	Safety.....	42
4.5.2	Painting	43
4.6	Methods to Achieve High Availability	43
4.6.1	Total Redundancy	43
4.6.2	Redundancy of Selected Components.....	43
4.6.3	High Pressure Hydrogen Storage	44
4.6.4	Local Stock of Spare Parts	44
4.7	Proposed Layouts	44
5	Application of the Design to the Orkney Islands	46
5.1	Hydrogen Demand	46
5.2	Existing Hydrogen Equipment in Orkney	46
5.2.1	On Shapinsay:.....	47
5.2.2	On Eday:	47
5.2.3	Operating between Eday, Mainland and Shapinsay	47
5.3	Harbour Equipment for Fast Filling of Ferry in Kirkwall	47
5.3.1	Assumptions:.....	47
5.3.2	Harbour Equipment Option 1: Compress from Tube Trailers.....	48
5.3.3	Harbour Equipment Option 2: Cascade fill from Static Storage	49
5.3.4	Fast Filling at Kirkwall Harbour Conclusion.....	50
5.4	Harbour Equipment for Slow Filling the Ferry in Shapinsay	50
5.4.1	Option1: Tube Trailer Deliveries	51
5.4.2	Option2: Pipeline to Harbour.....	52
5.4.3	Slow Fill at Shapinsay Harbour Conclusion	52
5.5	Hydrogen Generation at Existing Site	52
5.5.1	Wind Turbine	53
5.5.2	Electrolyser.....	53
5.5.3	Storage	55
5.5.4	Compressor and Buffer Storage.....	57
5.5.5	Tube Trailer Connection Points.....	58
5.5.6	Approach to Achieve >99% Availability	58
5.6	Hydrogen Generated at a new Site, with Pipeline at 350bar to Shapinsay Harbour.....	59



DUAL Ports

De-carbonising port business today

5.6.1	Wind Turbine	60
5.6.2	Electrolyser.....	60
5.6.3	Storage	61
5.6.4	Compressor and Buffer Storage.....	61
5.6.5	Pipeline.....	61
5.6.6	Tube Trailer Connection Point	61
5.6.7	Approach to Achieve >99% Availability	61
5.6.8	Example Layout Drawings	62
6	Business Cases.....	64
6.1	Fast Filling at Kirkwall Harbour.....	64
6.2	Slow Filling at Shapinsay via Tube Trailer Deliveries.....	66
6.3	Slow Filling at Shapinsay via a 200bar Pipeline	67
6.4	Slow Filling at Shapinsay via a 350bar Pipeline	68
6.5	Conclusion of Assessment of Business Cases.....	70
7	Conclusion.....	71
8	References.....	72
9	Appendix 1: Maintaining Supply when Connected to a Wind Turbine	74
9.1	Basic Turbine Data.....	74
9.2	Storage Requirements based on only using Curtailed Energy	77
9.3	Storage Requirements based on using Curtailed and Uncurtailed Energy	80
9.4	Storage Requirements based on using Curtailed, Uncurtailed and Grid Energy	82
10	Appendix 2: Hydrogen Required for Cascade Filling.....	84



De-carbonising port business today

1 Background to Project

Over 90% of the world's internationally traded goods do so by international shipping, making it a vital industry for economic well-being. However, shipping accounts for 1.12 billion tonnes of CO₂ released each year, or nearly 4.5% of global emissions, and in the absence of action is predicted to rise to 50% of global emissions by 2050 [1]. Despite this, shipping was excluded from both the Kyoto and Paris climate agreements, which has caused considerable concern.

However, this situation changed in April 2018, when the International Marine Organisation (IMO) agreed to cut emissions from shipping by 50% by 2050, compared to 2008 levels [2]. There is concern within the industry about how these reductions are achievable.

For several years, Liquefied Natural Gas (LNG) was touted as green alternative to marine oil, and in many ways it is considerably superior with respect to sulphur, NO_x and particulate emissions. However, the CO₂ emissions are at best only 20% lower than diesel, with some claiming that the levels are actually comparable once the liquefaction and transportation energies have been taken in to consideration. Hence LNG, is still carbon intensive.

Thus, in anticipation of the recent IMO announcement, companies have been reticent to heavily invest in LNG, an option that is not considered future-proof. Thus, by March 2017, only 103 LNG powered vessels were in operation, with a further 97 on order [3].

Batteries is another option regularly proposed as a solution for shipping, however, as considered in more detail in this report, they lack the energy density for anything but the shortest routes.

The remaining high profile option, and the focus of this report, is hydrogen. The key advantages of hydrogen are that it can be made directly from the splitting of water by electricity, by electrolysis (producing a storable clean fuel that is omnipresent, rather than being sourced from a few countries with the good fortune to be above an oil or gas field), and if that electricity comes from renewable sources, then the resulting fuel is zero carbon. However, at present, there are few maritime hydrogen vessels and hence no bunkering solutions.

ITM Power is a UK SME who is a global leader in the design and manufacture of rapid response electrolyzers, the equipment to produce hydrogen from water. The company also sell complete turn-key hydrogen solutions. This includes hydrogen refuelling solutions for vehicles. Notable successes in this area include:

- Rolling out of a network of the UK's current hydrogen refuelling stations
- Two hydrogen refuelling stations in California
- The world's largest hydrogen bus refuelling station in Birmingham, UK
- Building the first bus refuelling station in France

ITM wish to apply their existing knowledge of hydrogen refuelling vehicles to develop a bunkering system for marine vessels.

DUAL Ports

De-carbonising port business today

Orkney Islands Council (OIC) are partners in the DUAL Ports project, through their subsidiary Orkney Marine Services, which operates all ports in the Orkney Islands. Several of OIC's fleet of vessels will need replacing in the need future, and hydrogen fuel is an option that they are considering. Thus, while ITM are developing a general bunkering solution, its application to the specific case of Orkney has been considered in this report.



De-carbonising port business today

2 Selection of Hydrogen Bunkering Technology

2.1 General Considerations of Hydrogen Vessels and Refuelling

In consideration of hydrogen bunkering system design, the key challenge is that the hydrogen vessels have not been designed, and there are no standards to work to. Furthermore, whilst a diesel bunkering system for vessels is largely independent of the vessel design, this is not the case for hydrogen.

The following sections detail the possible options for producing power from hydrogen, and the storage and bunkering of the hydrogen.

2.1.1 Method of Vessel Converting Fuel to Power

As hydrogen is such a flexible energy carrier, many options are available for converting hydrogen into power on the vessel. Each has specific storage requirements and efficiency, which in turn will affect the bunkering solution. Some options are listed below:

2.1.1.1 Conversion to electricity in a fuel cell.

Fuel cells are usually the first consideration when discussing hydrogen propulsion. A fuel cell is a device that converts hydrogen and oxygen into water and power (the reverse reaction of an electrolyser). Two key types are available:

- **Low temperature (PEM) fuel cells.** These operate at ~40-50% electrical efficiency and have low grade (~60C) heat as a by-product. They are quickly able to ramp up and down in response to load demands.
- **High temperature fuel cells (MCFCs and PAFCs).** They operate at ~200C, so have high grade waste heat available, and have an efficiency of ~50-60%. However, their high operating temperature means that they have slow start-up times and prefer to operate at a continuous output.

Fuel cells are presently expensive (~€1-2M/MW).

2.1.1.2 Combustion of hydrogen in a gas engine or turbine.

A consequence of LNG being used as a fuel on vessels is that there is a range of gas engines presently being used to power vessels. These could be adapted reasonably easily (mainly changing the timing to take account of the higher flame speed and combustion temperature). However, because negligible testing of these engines has been undertaken with hydrogen, the efficiency seems pure speculation at this stage, however, ~35% electrical efficiency in a gas engine and 40% in a gas turbine seems likely.

De-carbonising port business today

2.1.1.3 Co-Combustion of hydrogen with other fuels

Hydrogen may be co-combusted with diesel (up to 80% of diesel by energy may be displaced) in a diesel engine¹, or mixed across the full range of concentrations with natural gas in a gas engine or gas turbine. While an engine can be set up for a specific hydrogen concentration, a continuing varying range will require dynamic timing adjustment, something that is possible with modern engines, but not older ones. Again a lack of real world experience is an issue, but efficiencies of ~30% seem likely.

2.1.2 Method of Storing Hydrogen

As a flexible energy carrier, hydrogen has many options for storage. However, while hydrogen has a far higher specific energy density than any other fuel, the main problem with hydrogen is one of low volumetric energy density. This is illustrated in Figure 1.

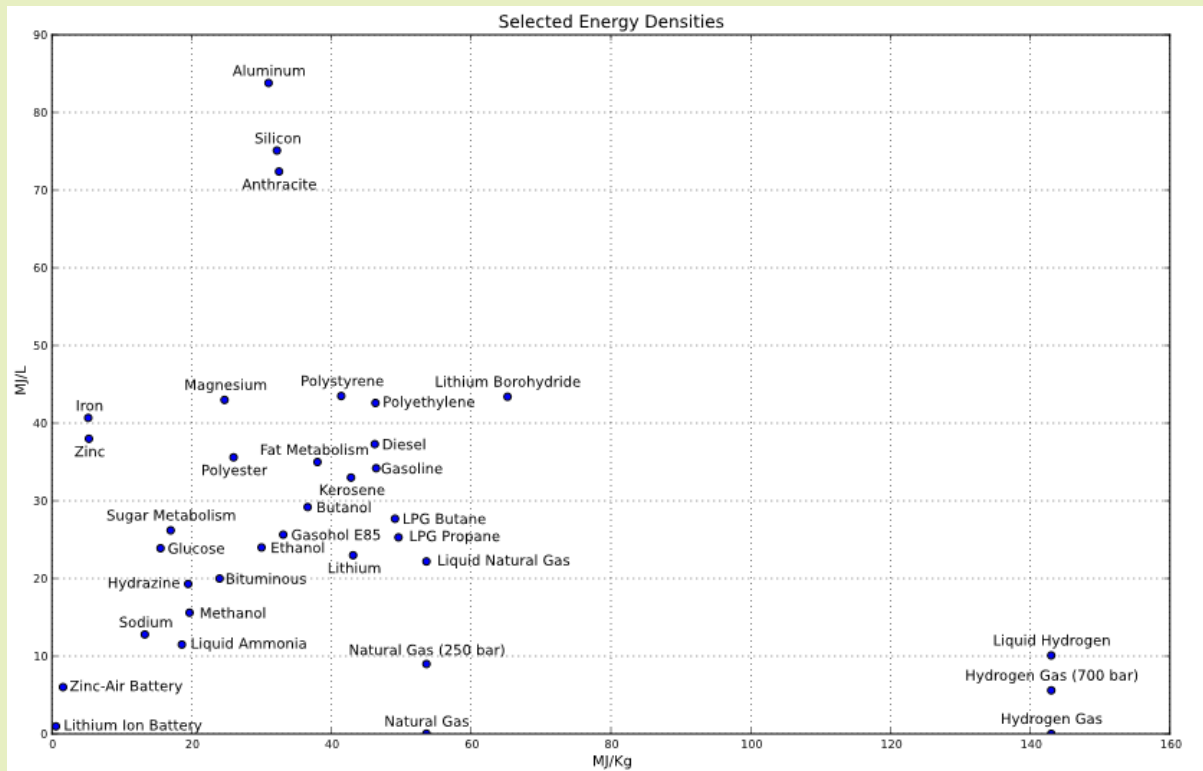

Figure 1. The volumetric energy density of different fuels as a function of the specific energy density [4].

Of particular note is:

- As stated, hydrogen has high specific energy density, but low volumetric energy density, meaning that one tonne of hydrogen at 700 bar will contain 3 times the energy of one

¹ Further dilution is not possible as diesel engines are not spark ignition. Therefore some diesel is required in the cylinder to ignite the hydrogen.

De-carbonising port business today

tonne diesel, but take up 6 times the space. Liquefied hydrogen (LH₂) has about twice the volumetric energy density of hydrogen, but is still 1.5 times lower than LPG.

- Rechargeable lithium ion batteries, promoted by many as a future power source for vessels have very poor volumetric and specific energy density. Many have suggested that battery energy density will follow a Moore's law type curve, including Tesla's press releases from ~10 years ago. However, despite considerable improvements in battery cost, energy density has remained stubbornly flat. See Figure 2.

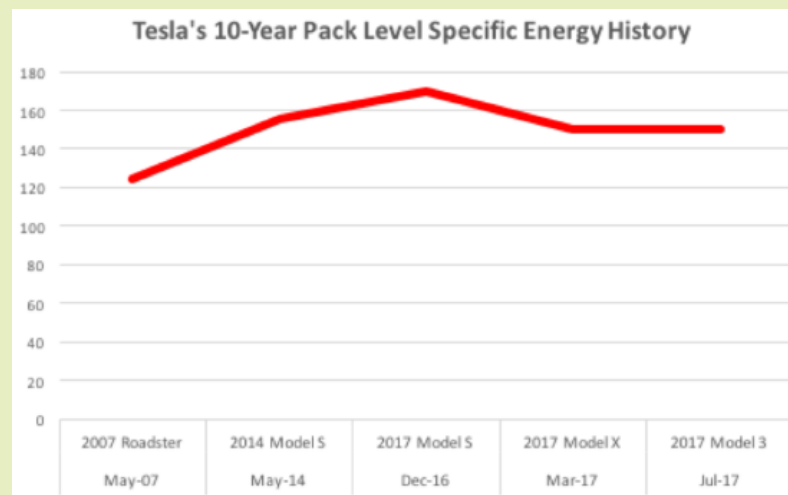

Figure 2. The specific energy density of batteries in different models of Tesla moving forward in time showing that battery improvements are difficult to achieve [5].

On this basis it is believed that hydrogen is a (possibly the only) viable solution for the shipping industry going forwards. However, clearly, the concerns over volumetric energy density need to be addressed. Options for the storage of hydrogen are presented below:

Gaseous Hydrogen. This is the solution that hydrogen cars, buses and trains all use. Hydrogen is stored at 350bar (buses and trains) or 700bar (cars). Despite the obvious attraction of storing at 700 bar, larger vehicles use the lower pressure standard, as refuelling at higher pressure requires more complex refuelling equipment including IR communication between refuelling station and vehicle, pre-chilling the gas to -40C and careful control over the flow of hydrogen. This all adds complexity and considerable cost. Thus, larger vehicles that tend to have more available space have generally opted for the 350 bar standard.

Aside from the general safety consideration of the storage of a high pressure flammable gas on the vessel, a key concern is that during the refuelling process, hydrogen is compressed into the storage cylinders. Heat is released during such adiabatic compression, which if left unchecked, could soften the pressure vessels, leading to catastrophic failure. Therefore, when bunkering hydrogen, it is critical that the flow rate of hydrogen is controlled.

De-carbonising port business today

Liquefied Hydrogen (LH₂). All manufacturers that are considering developing a hydrogen vehicle look at the volumetric energy density of hydrogen and initially decide to use liquefied hydrogen. However, most rapidly change their minds. The key reasons are:

- Hydrogen is very difficult to liquefy. The phase diagram for hydrogen is presented in Figure 3.

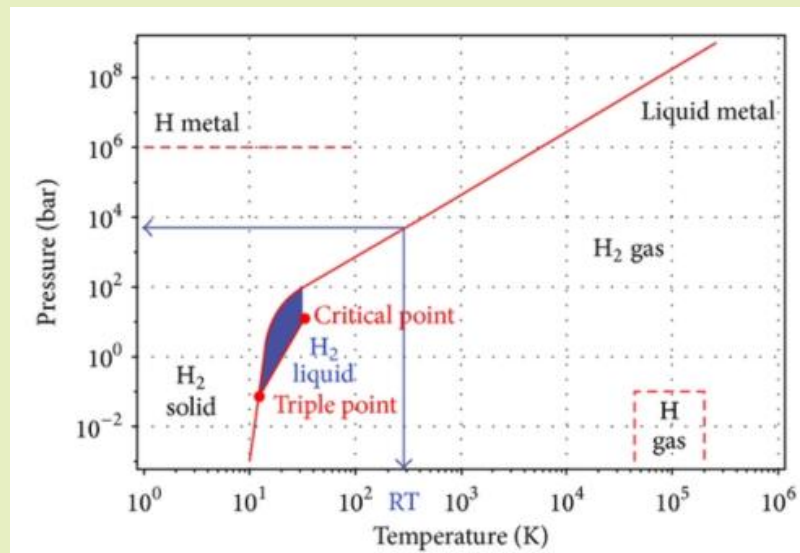

Figure 3. The phase diagram for hydrogen, with room temperature highlighted [6].

At atmospheric pressure it liquefies at -253C [7] (only 20C above absolute zero), which compares to -162C for LNG [8]. It therefore requires expensive equipment and considerable energy to liquefy hydrogen.

- There are only two hydrogen liquefaction plants in Europe, each with little spare capacity. Therefore, only small amounts are available and it is expensive to transport to wherever required, as invariably where needed is a considerable distance from one of the two production sites.

Despite these issues, while liquefaction of hydrogen is difficult, it is clearly possible. Once there is a demand, the business case will follow for the supply, and liquefaction plants will be built to meet the new hydrogen demands.

In practical terms, a ship would require a cryogenic tank where the liquid hydrogen could be stored and with an evaporator to convert the liquid to gaseous H₂. While this would have been unusual 10 years ago, the advent of LNG shipping means that this technology is now reasonably well understood in the marine environment.

Metal Hydride Storage. Due to its small molecular size, it is possible to store hydrogen within the crystal structure of certain metals at a density that is higher than that of LH₂. The downside is that they only have a storage efficiency of 5-8% by mass – therefore, if 1000kg of hydrogen is required, up to 20t of metal hydrides are needed. On a road vehicle, this mass is unacceptable, but on a ship, this could be considered an option.

De-carbonising port business today

A further benefit of metal hydride storage is safety. Were a leak to occur, hydrogen would be released from the metal matrix to produce gas at an equivalent of ~15 bar, considerably lower than the 350-700 bar discussed previously. The release rate is also self-limiting: if hydrogen is released too quickly from the metal hydride, it cools, preventing further release. While a safety benefit, in daily use this presents a problem: The release of hydrogen is highly endothermic, therefore heat (energy) needs to be supplied to the metal hydride to maintain the release. This presents an engineering problem for large metal hydride stores (heat exchangers need to be embedded within the metal hydride stores, which are themselves pressure vessels) and an efficiency problem (~25% of the energy stored as hydrogen if required to release the hydrogen from the metal hydride).

Liquid Organic Hydrogen Compound (LOHC). In recent years, a new method of hydrogen storage has been developed whereby hydrogen is used to hydrogenate a light oil (for example by Hydrogenius). This non-flammable, non-toxic, energy dense, unpressurised substance can then easily be transported to where it is required. Here, a dehydrogenation reaction is undertaken and the hydrogen is released for use, and the oil can be returned for re-hydrogenation.

While the benefits of this type of system are clear, there are potential issues:

- Hydrogenating the oil is an exothermic reaction – but this is not a huge issue as the heat can be relatively easily dissipated. However, the dehydrogenation reaction is endothermic, requiring considerable heat input for the reaction to proceed: ~20-25% of the energy stored in the hydrogen that is being released. Therefore unless the operator is prepared to sacrifice 20-25% of their fuel, a heat source is required nearby.
- The hydrogen purity requirements for fuel cells are exceptionally high (99.999%), and it is not clear if the hydrogen released in the dehydrogenation reaction is of suitable quality. However, this is not a concern for combusting hydrogen.

2.1.3 Method of Bunkering Hydrogen

Clearly, the bunkering method depends completely on the method of fuel storage. This is summarised below:

- **Gaseous hydrogen:** Stored as a gas at the port and transferred to the vessel. As discussed, the flow rate of the hydrogen needs to be carefully controlled to prevent excessive adiabatic heating. There are two key options for transferring gaseous hydrogen to the ships:
 - **Pressure balancing:** Store hydrogen in the port at a higher pressure than the vessel requires (for example, a ship requiring 350 bar would commonly have 500 bar stored in the port). Then open a valve and allow the hydrogen to flow into the vessel under its own pressure. This method does not require compressors to move the gas across at high throughput, but needs considerable storage capacity at the port, as much of the storage is inaccessible (once the pressure in the port storage drops below 350 bar, it is unable to fill a ship to 350 bar). This can be mitigated to

De-carbonising port business today

some extent by the use of ‘cascade filling’ whereby several smaller hydrogen stores are employed and each is utilised in turn to fill the ship to the required level

- **Compressing the gas into the ship.** A high throughput compressor is used to move hydrogen from a low pressure (typically 20 bar) store in the port, to the ship. This allows careful control of the hydrogen flow, but requires expensive equipment.
- **Liquid hydrogen:** Stored as liquid hydrogen at the port, and transferred to the vessel using cryogenic pumps. This technology is now reasonably well understood from experience of bunkering LNG. However, while LNG is generally transported to a port for subsequent bunkering, it is likely that a hydrogen liquefaction plant would be located nearby.
- **Metal hydride:** Stored as a high pressure gas at the port and transferred to the vessel either using pressure balancing or transferred via a compressor. Heat extraction is required from the store to allow the hydrogen to enter the metal matrix.
- **LOHC:** Stored on the dock as hydrogenated organic compound. Transferred to the vessel via pumps. Dehydrogenated oil removed from the vessel and also stored at the port.

2.1.4 Hydrogen Generation

Unlike natural gas, hydrogen cannot be mined – it must be produced. Two methods are commonly used:

- Split methane (extracted from natural gas) into hydrogen and carbon dioxide using a steam reformation process. This is a low cost method of production, however, the production of CO₂ largely mitigates any benefit from using hydrogen. Proponents point to carbon capture and storage (CCS) as a solution. However, this is geographically restricted to locations where defunct gas/oil wells exist and despite considerable interest, very few demonstration sites exist around the world, mainly due to the economics of taking large amounts of atmospheric CO₂ and compressing it to up to 100bar.
- Split water into hydrogen and oxygen using electrolysis. If the electricity used for the electrolysis is from renewable sources, then the hydrogen produced is zero carbon. This is promoted by many as the most sustainable method for hydrogen production and will be taken forward for further study.

One area for consideration is regarding the location of electrolysis equipment, which in turn can depend on the renewable source. If this is a marine energy source (such as wave or tidal devices) then having the electrolyser located in the port would make sense. However, if the source were a wind turbine on top of a nearby hill, then a decision would need to be made about whether it is best to locate the electrolyser adjacent to the turbine, to minimise cable runs, but would require a pipeline or regular tube trailers to go to the port; or to locate the electrolyser at the port, which would prevent the need to long pipe runs or tube trailer deliveries, but would require a long cable run. This decision would need to be made on a site by site basis.

DUAL Ports

De-carbonising port business today

2.2 Identification of Preferred Options

Although Section 2.1 identified many possible ways for hydrogen to be generated, bunkered, stored on the ship and converted into power, there are synergies between them that allow certain options to be grouped. These are shown in Table 1.



DUAL Ports

De-carbonising port business today

Option	Generation	Bunkering	Storage on Ship	Conversion to Power
1	Electrolysis	Conversion to liquid H ₂ . Pump onto vessel	Cryogenic tank, then evaporator	Gas engine
2	Electrolysis	Hydrogenation of light oil, pump into ship	Tank of LOHC, then dehydrogenation unit	Gas engine
3	Electrolysis	Storage of 350 bar gaseous hydrogen, compression or cascade fill into ship	Metal hydride	Gas engine
4	Electrolysis	Storage of gaseous hydrogen, compression or cascade fill into ship	Compressed hydrogen tanks	Fuel cell

Table 1. Summary of the best options

De-carbonising port business today

The justification for each option is described below:

2.2.1 Option 1: LH₂

As described, this is the option most pushed by industry due to the high volumetric energy density of liquefied hydrogen. Some interesting large scale studies have investigated the practical and safety aspects of LH₂ as a fuel, notable one by Sandia National Laboratory [9].

When using LH₂, a gas engine is selected over a fuel cell as the excess high grade heat can be used for the evaporation of LH₂, reducing the size of the evaporator and reducing the risk of icing.

As discussed, LH₂ is considered the only viable solution for international shipping, and the above configuration is the most viable.

An interesting option here for the rollout of LH₂ is to work with the LNG industry. LNG projects are presently struggling to acquire funding, due to investors belief that the technology will be superseded by lower carbon solutions. This coincides with the problem that the LH₂ industry is struggling to start because there are few sources of LH₂ and none will be built until there are demands of LH₂. An interesting solution to both of these problems would be to encourage the LNG industry to build their vessels, tanks, pumps and evaporators to be capable of operating at the lower temperature LH₂ specification. The consequence is that:

- LNG vessels and equipment could be sold as 'LH₂ ready', de-risking the investment
- The investment case for building more LH₂ production plants is simpler as there will be many (hundreds / thousands) of vessels at sea that could be converted to be fuelled by LH₂ for minimal cost

An obvious extension of this proposal is to use LNG to reduce the investment required for LH₂ shipping to become a reality. At present, if a vessel requires 1 tonne of H₂ per day, this would require an electrolyser of ~2.5MW input power operating continuously. However, if it were powered from a wind farm with 25% capacity factor, it would require, on average, a 10MW wind farm. However, the wind does not blow continuously. Thus options for guaranteeing supply include:

- Connecting to a larger capacity wind farm and exporting the excess power to the grid
- Storing a large amount of hydrogen (perhaps a week or two) as a cache
- Having redundant electrolysers, compressors etc.

All of this adds considerable cost.

However, if the vessel is designed to accept either LNG or LH₂, It would be possible to split the on-board cryogenic storage into several discrete tanks, which could then be filled with either LNG or LH₂, depending on the availability of H₂. The gases could then be mixed in the evaporator and fed into the gas engine, which would need to have variable timing to cope with the different combustion properties of different gas mixtures.

DUAL Ports

De-carbonising port business today

2.2.2 Option 2: LOHC

The LOHC solution requires the hydrogen to be fed into a gas engine so that the excess high grade heat can be used to supply the energy for the dehydrogenation reaction.

While in theory LOHC is a viable solution for zero carbon hydrogen shipping, there are too many unknowns with this system to be considered. ITM have attempted to have technical discussions with the companies involved, but they were unable to answer some reasonably basic questions about the operation of the system. Therefore, LOHC is discounted.

2.2.3 Option 3: Metal Hydride

In common with LH₂ and LOHC, the storage of hydrogen as a metal hydride would require the hydrogen to be combusted in a gas engine to allow the excess high grade heat to be used to provide energy for the endothermic reaction to release hydrogen from the metal matrix.

While metal hydrides appear a viable solution for ships where weight isn't such a problem, they will lower the specific energy density of hydrogen from 142 MJ/kg, to 7 MJ/kg, which could be a real concern for ship operators. At this stage, metal hydrides will not be considered further.

2.2.4 Option 4: Gaseous H₂

As this is the only option that does not require heat input to operate, this has been recommended to operate with fuel cells, however, a gas engine would also be suitable, particularly if some of the options discussed in Section 2.1.1 of lowering cost by co-firing with natural gas were to be considered.

While 350 bar hydrogen would result in a very poor volumetric energy density, the technology for refuelling at this pressure is well understood and requires considerably less investment than an LH₂ plant. However, it wouldn't be suitable for any ship except short ferry routes, nevertheless, these are the routes that are being considered first for hydrogen, because:

- The short routes are suitable for existing 350 bar technology
- They are comparatively small, low risk vessels that do not operate far from shore, so are ideal demonstrator units
- They return to the same port (up to several times a day), so rather than needing a rollout of hydrogen equipment across a large number of ports, they can install in a single location



DUAL Ports

De-carbonising port business today

2.3 Option taken forward for Detailed Design

As discussed in Section 2.2, both gaseous H₂ and LH₂ are viable to take forward for detailed study, with LH₂ being a medium to long term solution, and gaseous being short term. However, the choice as to which should be studied has been determined by what is likely to be needed in Orkney (the pilot location) in the near future: Here, there is a reasonable chance for a gaseous hydrogen ferry and a second ferry co-combusting a gaseous hydrogen auxiliary power unit (APU) will be delivered to Orkney in the next 2 years. As such a gaseous bunkering system will be taken forward for detailed design.



De-carbonising port business today

3 Comparison between Safety of Hydrogen and LNG

3.1 Introduction to Safety of hydrogen and LNG

While a comparison between the safety for LNG and hydrogen is not required for the design of the bunkering system, this is a requirement of the DUAL Ports application.

Rather than just consider 'Hydrogen' and 'LNG', this will be broken down to both compressed gaseous and liquefied hydrogen. It should be noted that:

- Gaseous hydrogen and natural gas themselves are not flammable. They are only flammable when mixed with oxygen (or another oxidant). Thus hydrogen or natural gas in a sealed vessel is not flammable, but if it leaks into the environment, this will be flammable.
- For both LNG and LH₂, the liquefied gas itself is not flammable, but the gaseous hydrogen and natural gas that evaporates from its surface (when mixed with air) is flammable.
- Hydrogen and natural gas at atmospheric pressure are both lighter than air (although hydrogen significantly more so), so will rise in the event of a leak. However, the boil off gas from an LH₂ or LNG leak will both be heavier than air due to their temperature.
- The purpose of this assessment is to enable those familiar with LNG to make a comparison to the 'new' hydrogen fuel. However, it should be noted that hydrogen is an industrial gas that is produced, transported and consumed in vast quantities all over the world – about 53 million tonnes per year [10]. Pipelines hundreds of km long transport hydrogen in various countries. Therefore, hydrogen is a gas that industry understands and has developed and applied appropriate safety protocols for use.

A summary of the physical properties are considered in Table 2.

DUAL Ports

De-carbonising port business today

	Gaseous Hydrogen	Liquefied Hydrogen	Gaseous Natural Gas	Liquefied Natural Gas
Storage temperature (C)	Ambient	<-253	Ambient	<-162
Lower flammability limit (% in air)	4	NA	5	NA
Upper flammability limit (% in air)	75	NA	15	NA
Minimum ignition energy (μ J)	19	NA	280	NA
Density at atmospheric pressure (as a fraction of air)	0.074	NA	0.58	NA
Buoyant velocity in air at NTP (cm^2/s)	1.2 – 9	NA	0.8 – 6	NA
Diffusivity (cm^2/s) [11]	0.61	NA	0.16	NA
Steady state vaporisation rates of liquid pools without burning (cm min^{-1}) [11]	NA	2.5-5	NA	0.05-0.5
Minimum auto-ignition temperature (C) [11]	585	NA	540	NA

DUAL Ports

De-carbonising port business today

Adiabatic Flame Temperature in air (K) [11]	2318	NA	2158	NA
Burning Velocity in air [11]	265 - 325	NA	37 - 45	NA
Upper Wobbe Index (MJ/Nm3) [12]	48.2	NA	53.7	NA
Calorific Value (higher heating value) [13] (MJ/m3)	12.7	NA	39.8	NA
Thermal energy radiated from flame to surroundings (%) [11]	17 - 25	NA	23 - 33	NA

Table 2. Summary of the safety between hydrogen and LNG.

3.2 Discussion of Safety Data

All fuels are energy stores and if energy is released in an uncontrolled way from any fuel it presents a danger, therefore, when undertaking a safety comparison between two fuels, the differences in safety are marginal when compared to non-fuels.

3.2.1 Comparing Gaseous Hydrogen and Natural Gas

Both gases are stored in high pressure vessels. As discussed, hydrogen is generally stored at either 350 or 700bar, while CNG is rarely stored above 200bar as at ambient temperature it liquefies above this pressure. Thus there is an obvious benefit in storing at lower pressures; however, in 'normal' operation, the vessels do not present a safety risk. This primarily comes from failure events leading to:

3.2.1.1 A leak scenario

This results in a high pressure supersonic jet of gas, which eventually slows to a plume of gas which will dissipate. However, a jet is not a significant hazard – this only occurs when ignited (and this is prevented by the correct application of hazardous area classification). The outcomes can be broadly split into:

- The jet ignites soon after release. Those in the direct line of the jet will suffer significant burns, equipment in the direct line will be damaged. The energy of the flame depends on its calorific value (significantly higher for methane) and the volume of gas that can escape the hole, which in turn depends on its viscosity (lower for hydrogen). These effects are brought into a single metric, referred to as the Wobbe index and as shown in Table 2, these are broadly similar for hydrogen or natural gas, so they present a similar hazard.
- The jet ignites sometime after the release. The area surrounding the leak has an explosive cloud of gas present which ignites, leading to a deflagration and possible detonation of the gas. Outdoors, hydrogen is probably safer due to its ability to diffuse away quicker and higher buoyancy, meaning less is available to ignite. However, in an enclosed area, such as a compartment on a ship, this will have little benefit. Here, methane is probably safer as hydrogen higher flame speed means that hydrogen has a higher propensity for the flame deflagration to turn to detonation, particularly in a 'cluttered' area. Detonation of the gas releases considerably more energy and is more destructive.

3.2.1.2 A pressure vessel failure.

A vessel failure is a catastrophic event that will instantly release all of the pressurised contents of the store. Given the energetic pieces of metal that will be projected at high velocity, it is likely that a spark will be present that will ignite the release, leading to a second explosion. Causes of this could be corrosion of the cylinders, over pressurisation of the cylinders, general softening of the vessels due to a fire in the compartment or localised softening of the cylinders caused by an ignited jet fire. In this situation, it could be considered that hydrogen was more dangerous as the tubes are stored at higher pressures, so the initial energy release would be higher. However, the

De-carbonising port business today

energy released from decompressing the gas is an order of magnitude less than the energy of the fuel it contains and for the secondary ignition of the released gas, for given tube size, natural gas has 3 times the calorific value so would release considerable more energy than an equivalent hydrogen tube. However, given the wider flammability limits, several times more of the hydrogen is likely to actually be ignited.

Thus, while this is a highly undesirable event with either gas, there is probably little difference in the energy released between hydrogen and methane.

3.2.2 Comparing LH₂ and LNG

Under normal conditions, both LH₂ and LNG are stored in thermally insulated atmospheric pressure vessels, which could present a cryogenic hazard. Normally, the insulation on vessels and pipes will prevent direct contact with these low temperature gases. The main hazards are thus associated with a loss of containment, which can be divided into two scenarios:

3.2.2.1 A minor leak of liquefied fuel

A minor leak of liquefied fuel (dripping, or a trickle) will present a minimal cryogenic hazard to staff as it will evaporate on contact with clothing / skin. The hazard is thus that it will rapidly evaporate, releasing a plume of flammable gas. In theory hydrogen will evaporate quicker, but in practice both will take seconds to become a hazard.

Outdoors, this flammable gas will rapidly dissipate and present minimal hazard. Indoors, gas detectors should identify the leak and the correct application of hazardous area zoning should prevent an ignition. However, in the event of an indoor ignition, for a given leak rate, the higher CV of methane, means that more energy will be released with an LNG leak, but the wider flammability limits probably mean that the energy released will be similar with hydrogen. However, should the hydrogen deflagration turn to detonation, then this will release considerably more energy, therefore the design of the room should be such that the chances of this event is minimised.

3.2.2.2 A major leak of liquefied fuel

This could be caused by the brittle failure or similar of a pipe, due to incorrect materials of construction. For a large release, evaporation will not be quick enough to prevent a pool forming. Pools of either gas will present a significant cryogenic risk. Hydrogen will evaporate quicker than natural gas, but outdoors it will dissipate quicker than natural gas. Indoors, as before, hydrogen probably presents a higher risk due to its higher likelihood of detonating.

3.3 Conclusion of Safety Comparison between Hydrogen and Natural Gas

Hydrogen and natural gas are both flammable fuel gases, can both fail in similar ways and present similar risks. In general terms, it is considered that they present broadly similar hazards, with methane being more hazardous in outdoor situations, and hydrogen more hazardous indoors.

De-carbonising port business today

4 Detailed Design of Gaseous Hydrogen Bunkering System

4.1 Background

The development of a gaseous hydrogen bunkering system is not being undertaken by ITM purely to meet the requirements of this project. On the contrary, ITM regard its development as a key commercial objective and one that will lead to future growth. As such, while ITM has undertaken a detailed design, as this project's outputs are public, it was agreed before commencing the project that the information that ITM would disclose would be limited, therefore, what is presented here, does not represent the entire design work, only that which ITM deem appropriate to be published.

4.2 Design Outline

While the plant will be designed for general application in Europe (for the purpose of this study, it will be designed to CE standards), the design's application to the specific example of Orkney has been undertaken. Kirkwall has been chosen, because they are a partner in the Hydrogen section of the Dual Ports project, but also because there is a reasonable probability of a hydrogen fuelled ferry being based on Kirkwall in 2 years' time. While funded, this project has not been formally announced, and therefore, few details have been released to ITM and even fewer can be revealed here.

One of the aspects that has not been specified (possibly because the design work has not yet been undertaken) is either the capacity of the ferry's hydrogen tanks or their maximum pressure – two key design parameters. However, the bunkering design will ultimately be applied to (hopefully) many ports and thus rather than focus it too specifically on meeting the needs of a particular vessel, it has been designed to be suitable for a range of ships and be both modular and expandable to increase its wider applicability.

Therefore, the general module will be sized at 2MW input (800kg H₂/day, if operated at full power continuously).

The system will comprise the following components:

- Power connection
- Power supply module, comprising
 - Transformer
 - Rectifier
 - Cooling
- Electrolyser module, comprising:
 - Site control room
 - Water purification
 - Electrolyser 'stacks'
 - Hydrogen purification
- Low pressure buffer store

De-carbonising port business today

- Compressor
- High Pressure storage²

Each of these components is discussed in detail in Section 4.4.

Depending on the level of availability required by the customer, additional equipment may be required, such as redundant components or additional storage. This is discussed further in Section 4.4.

4.3 Design Compliance

The plant will:

- Be designed to be CE marked to:
 - 14/68/EU Pressure Equipment Directive
 - 2006/42/EC Machinery Directive
 - 2014/30/EU Electromagnetic Compatibility Directive
 - 99/92/EC AtEx Directive (workplace)
- Have the following harmonised standards applied:
 - EN 60204-1:2006 + A1:2009 “Safety of machinery – Electrical equipment of machines Part 1: General requirements”.
 - EN 1127-1:2007 “Explosion prevention and protection - Part 1 - Basic concepts and methodology”, clause 6.2.
 - EN 60079-10-1:2009 “Explosive atmospheres - Part 10-1 - Classification of areas - Explosive gas atmospheres”.
 - EN 61000-6-2:2005 “Immunity for industrial environment”.
 - EN 61000-6-4:2007 “Emission standard for industrial environments”.
 - EN 13445-3:2009 “Unfired pressure vessels Part 3 – Design”, clauses 7.4.2, 10.4.4.1, 10.6.2.1 and 11.5.2.
 - EN 13445-5:2009 “Unfired pressure vessels Part 5 – Inspection and Testing”, clause 10.2.3.
 - EN ISO 4126-1: 2004 “Safety devices for protection against excessive pressure - Part 1 - Safety valves”.
 - EN 10272:2007 “Stainless steel bars for pressure purposes”.
 - EN 10216-5: 2004 “Seamless steel tubes for pressure purposes - Part 5 - Technical delivery conditions. Stainless steel tubes”.

The power conversion electronics comply with the following standards:

² Option to be present, depending on the refuel times available.

De-carbonising port business today

- IEC 60146 relating to the transformer
- IEC 62103 relating to the rectifiers
- IEC 60529 relating to the switch gear
- TAB 2007 relating to grid connections

4.4 System Components

4.4.1 Power Connection

As discussed in Section 2.1.4, the electrolyser requires a connection to a power source. If this source is renewable, then the hydrogen produced is zero carbon – a key objective of moving to hydrogen as a fuel. However, if connecting to, say, a wind turbine with 25% capacity factor, then the turbine will on average need to be 4 times higher output than may be expected. However, the capacity factor is calculated over a year, and hides considerable variation in production on a daily or weekly basis, thus leading to a considerable store of hydrogen being required to provide backup and ensure availability of refuelling. A more pragmatic approach would be to have perhaps 4 days storage (the general duration of a high pressure system over the UK) and a grid connection as reserve. While using the grid may significantly reduce the required storage, it will have a negative effect on the CO₂ footprint of the ship and the economics of refuelling, as grid power is generally more expensive than renewable power.

The usable output from a turbine, the requirements for different levels of storage and effects of using curtailed, non-curtailed and grid electricity is discussed in detail in Appendix 1: Maintaining Supply when Connected to a Wind Turbine.

In consequence, the exact details of the connection will vary depending on the renewable power source (eg. wind or tidal), the demand profile and whether topping up from the grid is acceptable. As a consequence of the analysis undertaken for this study, ITM have the tools to specify this for each customer, including the RE source if required. The application of this to Orkney is detailed in Section 5.

4.4.2 Power Supply Module

The time varying AC power being produced by the renewable energy source, cannot be used to generate hydrogen in electrolyser stacks; DC power of the correct voltage is required. Thus, a module has been specified that incorporates the following features:

- Stepdown oil transformer from 11kV³ to 450V AC and 400V AC
- EMC filter
- Clean Power Filter
- Incoming fuses
- 400V AC distribution

³ 11kV has been chosen for modelling, but and input voltage can be use.

DUAL Ports

De-carbonising port business today

- AC-DC water cooled rectifier
- DC-DC chopper
- Output reactor
- Outgoing Fuses
- Refrigerant chiller

The entire system will be packaged into a 30' ISO container and painted in 2 part epoxy paint to prevent corrosion in marine environments.

A single line drawing of the system is presented in Figure 4.

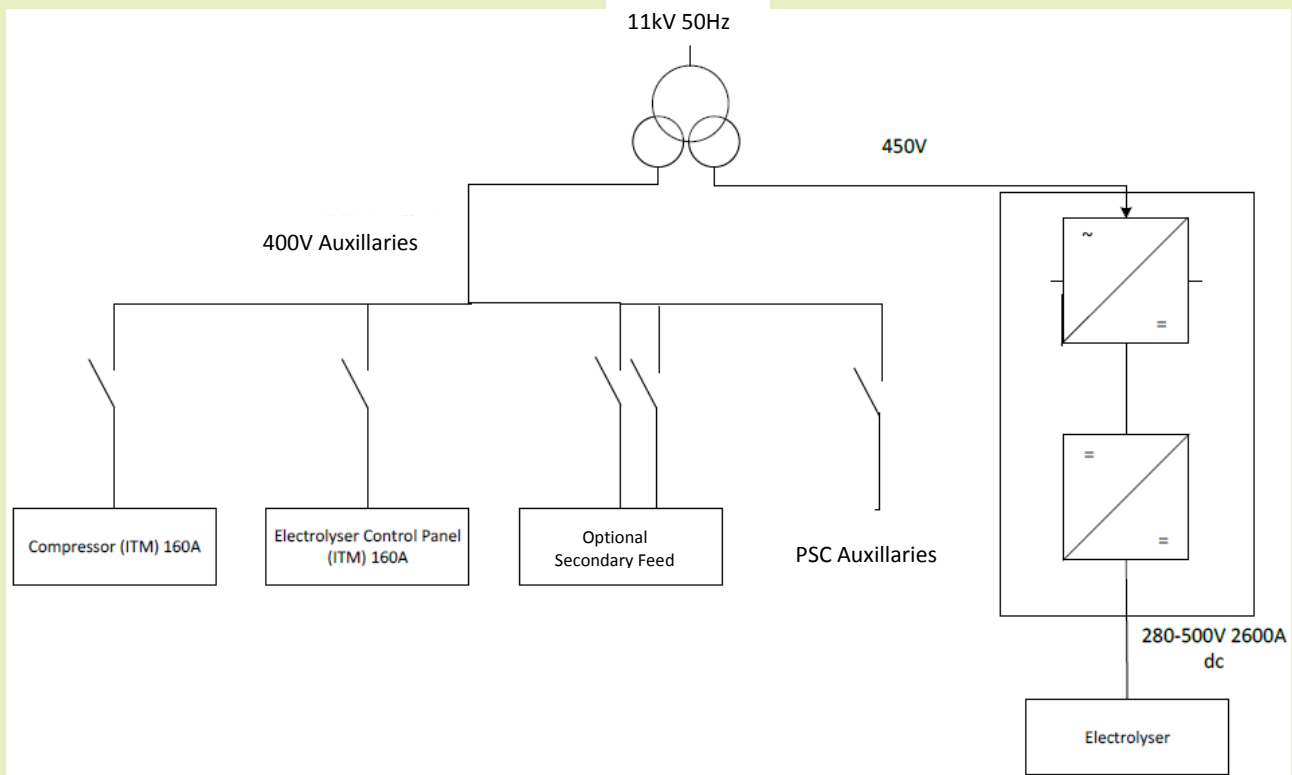

Figure 4. Single line drawing of the power supply module

The resulting system is a highly efficient system with an 'active front end', which allows the power factor to be tuned to the site's (and local power distribution company's) requirements. It could therefore be set to present to the grid / RE source as being more inductive or capacitive. This feature has value, particularly to grid distribution companies.

De-carbonising port business today

4.4.3 Electrolyser Module

ITM propose an electrolyser system based around ITM's fully integrated CE marked PEM electrolyser platform. The system is based around ITM's proprietary electrolyser stack design capable of self-pressurising up to 20bar.

The ITM system has been designed in accordance with the latest codes and standards and in-line with industry best practice. All parts and components have been carefully selected for their suitability for use in the electrolyser and refuelling equipment.

The electrolyser will provide a peak output of 807 kg H₂/day, produced by 3x stacks.

The electrolyser system will be packaged in a 30' ISO container for use outdoors.

The electrolyser container will be divided into four compartments (the hazardous area classification of each compartment is provided in brackets):

- Hydrogen generation (Zone 2 of Negligible Extent)
 - This will contain the electrolyser 'stacks', the electrochemical devices that split the water into hydrogen and oxygen
- Process equipment (not hazardous)
 - Various non-Ex equipment including pumps, valves, water purification and sensors
- Hydrogen purification (Zone 2)
 - Contains the hydrogen – water separation equipment
 - Oxygen removal equipment
 - Water removal equipment
 - Gas processing equipment
- Control room. This will include
 - The PLC for the electrolyser
 - The overarching system PLC, which will communicate with the rest of the equipment plant
 - A UPS to allow switchover to a standby generator in the event of primary power loss

In addition, the system has the following external equipment:

- Radiators
- Chillers

Renders of the proposed electrolyser system are provided in Figure 5 and Figure 6.

DUAL Ports

De-carbonising port business today

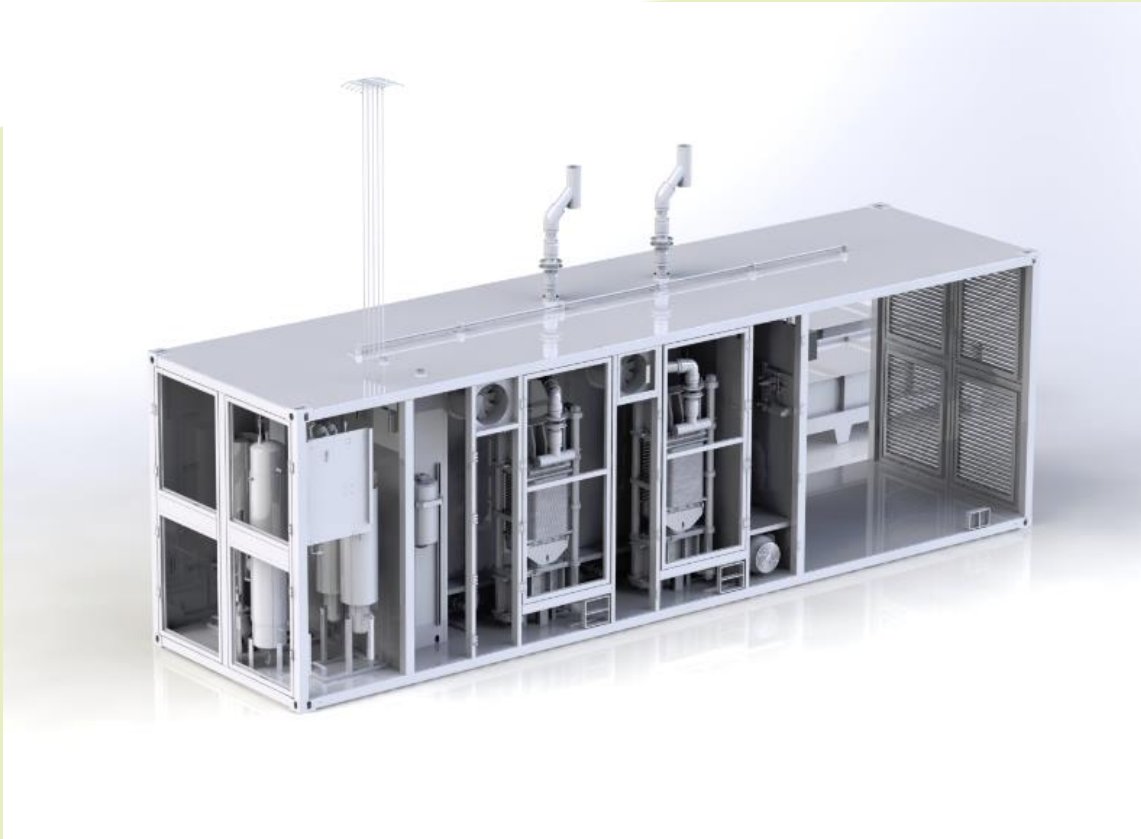

Figure 5: ITM's electrolyser container

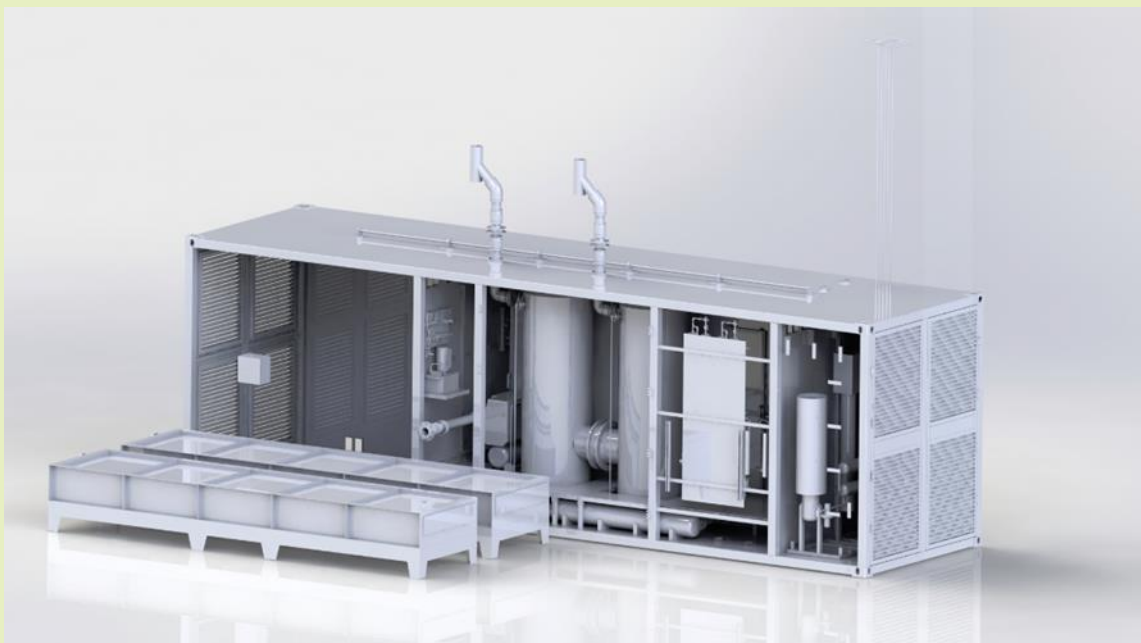

Figure 6: Reverse angle view of ITM's PEM electrolyser container and air blast chiller

De-carbonising port business today

4.4.3.1 Safety

While all of the system risks have been considered in a variety of safety studies, which cannot be published here for commercial reasons, the two main hazards are:

Hydrogen Leaks:

There are several methods of hydrogen leak detection. These are listed below in order of the increasing size of leak they are able to detect:

- Leak tests on the system, which will be undertaken by engineers as part of routine maintenance every 6 months will detect the smallest of leaks
- Automated pressure hold test: Once per day the system pauses hydrogen production for 1 minute and monitors the pressure in the system. Minor leaks will be detectable. The system will shut down if a leak is detected.
- Gas detectors: Leaks in the hydrogen generation compartment can be detected by gas sensors mounted in the roof above the equipment. The system will conduct an emergency shutdown (ESD) if a leak is detected.
- Pressure drop monitor / pressure rise monitor. For very large leaks, an unexpected drop in system pressure during operation, or failure to follow the expected pressure rise during start-up will initiate a shutdown.

Over Pressure:

In theory, an electrolyser is capable of producing hydrogen with increasing pressure until it fails. The system has several methods of protection against over pressure:

- The system pressure is monitored by 5 pressure transducers. These operate with a high level trip (which will operate under normal conditions and pause electrolysis when downstream vessels reach their set pressure)
- The 5 pressure transducers also have a high level alarm, which shuts down the system and opens the vent lines.
- The electrolyser system has 5 mechanical pressure relief valves, which vent to a safe location
- The system has been specified with components suitable for the media and pressures
- The system has been proof pressure tested

4.4.3.2 Water Purification

The system will incorporate incoming water purification, permitting the use of potable (tap) water. This is controlled automatically by the electrolyser control system and consists of the following steps:

- Particulate filter
- Reverse osmosis (RO) filter

DUAL Ports

De-carbonising port business today

- De-Ionised (DI) resin filters
- UV filters

The total expected water consumption by the system (including waste stream from the RO filter) is approximately 27 litres/kg hydrogen produced. No water is consumed by the system when the electrolyser is not generating hydrogen.

Note that to ensure that the filtration is correct for the local tap water quality, ITM will require the customer to supply a sample of local water for analysis.

4.4.3.3 Hydrogen Purification

A multiple stage hydrogen purification system is included which comprises:

- Bulk water-hydrogen separation
- Trace oxygen removal
- Water removal

Unlike most gas dryers, no hydrogen is wasted during the process, which helps raise the overall efficiency of the system.

The system is capable of ensuring the output hydrogen complies with ISO 14687-2:2012 and SAE Y2719, the standards for hydrogen road vehicles. Both of these require <5 PPM (by volume) of oxygen and water⁴. It is assumed that marine vessels will require a similar purity.

4.4.3.4 Backup Power

While the system is designed to electrolyse directly from a time varying renewable power source, which by its nature is often not producing output, the system requires a backup power source to run the plant control system, safety systems and allow the system to start producing output as soon as the RE source is available. A key additional function is to prevent the plant freezing: Without backup power in sub-zero ambient conditions, the water in the electrolyser will freeze, leading to substantial damage. As such, the system requires a secondary power source (grid, generator or secondary RE source) to always be available.

Because of the finite time to switch between sources (particularly if a backup generator is used), the system contains an uninterruptible power supply (UPS) which is designed to provide power to the PLC, for the time taken for the backup power supply to come online (30 seconds). Once the main power has returned, the system will automatically switch back to the primary power source and resume generation.

The system is designed to ensure safe operation at all times. In the event of total power loss, the system will shut down safely with no damage to any part of the system. The electrolyser will

⁴ Many other impurities are specified in the standard, but the output hydrogen from a water electrolyser can only contain water and oxygen as impurities.

DUAL Ports

De-carbonising port business today

remain in a safe condition until manually rebooted when it will return to the production of hydrogen.

4.4.3.5 Thermal Management

Thermal management including frost protection to prevent freezing in low temperature conditions and heat rejection systems are included. The system is suitable for use in ambient temperatures from -15 to 35°C (however ITM can offer an optional Climate Package to operate in colder and hotter ambient conditions).

The process fluids within the electrolyser are at a temperature of 55°C, and the heat generated in the electrolysis reaction is vented to air. If required, the system can be upgraded to include additional heat recovery equipment, so that the heat produced can be captured and used, for example, for space heating.

4.4.3.6 Control

The electrolyser will be controlled by a Siemens S7 PLC. This control system includes safety IO modules and thus integrates all safety and alarm systems. The system is designed for fully autonomous operation and includes all necessary process control and process safety features. The electrolyser PLC will send and receive signals from ITM's overarching PLC.

4.4.3.7 Response

The electrolyser system is capable of very rapid response. The electrolyser can respond to a cold start in <300 seconds, move from standby to generation in <60 seconds and modulate between set points in 2 seconds. The system is suitable for intermittent use and this will not affect the lifetime of the equipment.

4.4.3.8 Purging

There is no requirement for nitrogen to be used during any stage of normal operation, reducing the cost of regular nitrogen deliveries to site. Nitrogen is only used for maintenance purposes and will be supplied by ITM engineers.

4.4.3.9 Painting

The system will be painted in anti-corrosion paint to marine grade standard.

4.4.3.10 System Power Consumption

Electrolysers progressively decrease their efficiency during their lifetime. Thus, an electrolyser can either be configured to absorb the same amount of power, but progressively decrease its gas output, or maintain its gas output, but with increased power consumption. While it may be assumed that having a fixed gas output would be more useful when providing fuel for vessels, it should be noted that the widely varying daily output of RE sources (for example the wind turbine output studied in Appendix 1 had an average output of 4.1 ±5.5 MWh/day) results that the idea of a fixed hydrogen output is a fallacy. Instead, the system will run at a set maximum input power of 2000 kW (including all ancillary services such as fans, refrigeration, chillers, heaters etc.)

DUAL Ports



De-carbonising port business today

At the start of life, the expected hydrogen maximum output is 808kg/day, falling to an expected 691kg/day at the end of life. The largest consumers of power are the electrolyser stacks. Other energy consuming components within the electrolyser balance of plant include:

- Power conversion electronics
- Water circulation
- Gas purification system
- Ventilation
- Control system
- Refrigeration

The total system power will vary as a function of how these different systems turn on and off, the environmental temperature, operating point and differential pressure. The system has been extensively modelled and indication of electrolyser system power consumption as a function of input power is shown in Figure 7. Thus, as the input power from the RE source decreases, the electrolyser efficiency improves⁵, until a peak efficiency of ~600kW, below which the efficiency begins to fall again.

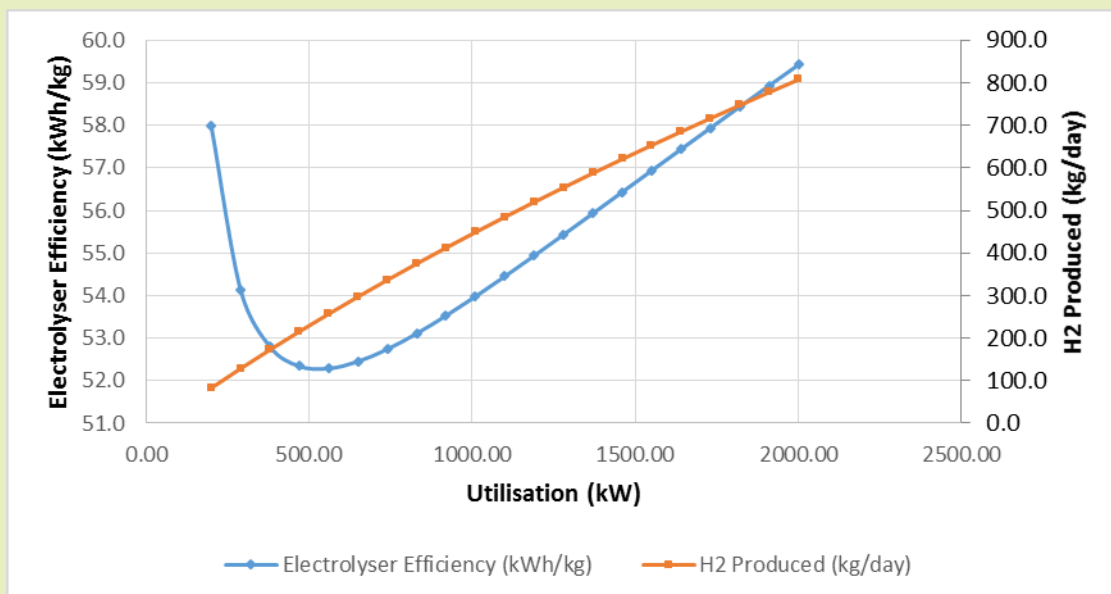

Figure 7: Indication of HGas system efficiency and H₂ production as a function of kW input when new

When the electrolyser is in hibernation, power consumption will be minimal, limited to frost protection and control systems. The actual power consumed will vary depending on environmental conditions but would typically be 7kW, and 25kW when freezing protection measures are engaged.

⁵ The graph decreases for a rising efficiency because a fall in kWh of electricity in per kg of H₂ output, represents a rise in system efficiency.



The key properties of the electrolyser system are provided in Table 3.

Parameter	Value
Stack Platform	MEP
Number of Electrolyser Stacks	3
Maximum Hydrogen Production when new (kg/day)	807
Maximum Hydrogen Production at end of stack life (kg/day)	691
Minimum Hydrogen Production (kg/day)	177
Water Consumption (litres/kg H ₂)*	27
Maximum Operating Pressure (bar)	20
System Efficiency Range (kWhr/kg)**	52-60 See Figure 7 for details
Load Control (%)	22 – 100
Cold Start (sec)	<300
Warm Start (sec)	<60
Modulation (sec)	2
Hydrogen Purity	99.999%
Expected stack lifetime (yrs)	9.7
Expected system lifetime (yrs)	20
Packaging	1x 30' ISO container + external chiller
Temperature Range (°C)	-15 to + 35
Average power at max output (kW)	2000
Control	PLC
Data Interface	Profinet/Modbus
Input Water Quality	Drinking Water
Certification	CE
Warranty Period (months)	12

Table 3. A summary of the key electrolyser properties

4.4.4 Low Pressure Buffer Tank

4.4.4.1 General

Low-pressure (20bar peak operating pressure) buffer tanks are required to take the output of the electrolyser and store before it is used in the compressor. This allows for:

- Different start-up times of the compressor and electrolyser
- The compressor and electrolyser to operate at different times. So for example, the electrolyser will need to operate whenever the RE source is available, while the compressor may only operate during the refuelling process
- Different hydrogen generation rates of the compressor compared to throughput of the compressor

DUAL Ports

De-carbonising port business today



Figure 8. A render of a typical example of a low pressure buffer tank.

Due to the relatively low pressures (20 bar) the vessels tend to be up to 2m in diameter and up to 7m high, however, a relatively low mass of hydrogen is stored.

The exact specification of the buffer tank will depend on a variety of factors including the RE source, the ship refuelling profile, the time available for each refuel, the approach to achieve high availability (see Section 4.5) and the space available on site.

Thus, ITM have received quotes for a variety of pressure vessel sizes from different European suppliers, which can be combined to form any total storage volume required. Although a vertical vessel is shown Figure 8, a horizontal one may be used. The choice depends on space available on the site and any local planning restrictions.

4.4.4.2 Control

Pressure transducers on the buffer tank will control both the electrolyser and compressor, with each turning on and off at set point. Controls will have redundancy, so a failed valve will not prevent the system operating.

4.4.4.3 Safety

In addition to the aforementioned pressure transducers (which have a “high” alarm that will instigate an ESD), each vessel contains two pressure relief valves. These are arranged with a 3-way valve connection to the tank, so that in normal operation both are in use, but for maintenance, each one can be isolated and removed for calibration without needing to vent the buffer tank. With this arrangement, it is not possible for the vessel to be left accidentally isolated from both valves.

In the event of a shutdown, normally closed valves will de-energise, isolating the storage from the rest of the system, which will help mitigate against the following scenarios:

De-carbonising port business today

- Reduce the volume released in a loss of containment scenario
- Prevent vessel failure in an over-pressurisation scenario
- Help prevent a domino effect where an emergency in one part of the plant (eg fire) can spread to another part of the plant

4.4.4.4 Painting

The system will be painted in anti-corrosion paint to marine grade standard.

4.4.5 Compression

4.4.5.1 General

The 20 bar output of the electrolyser is insufficient for refuelling vessels. As such a compressor is required to boost the pressure up to the required level. The compressor specified is a 2-stage design based on diaphragm technology. This type of compressor is ideally suited for use with hydrogen as the gas does not come into contact any lubricants, which reduces the risk of contamination of the hydrogen gas and reduces the maintenance requirements compared to other oil-free compressor technologies (for example dry piston compressors).

As described in Section 2.3, 350 bar hydrogen will be required on the vessel, therefore two options are available:

- Compress directly into the ship. Therefore the output pressure is 350bar and the flow rate depends on the refuelling window and fuel requirement (so, for example, a 500kg H₂ fill and a 4 hr refuelling window will require a 125 kg/hr flow rate).
- The ship is filled from high pressure storage vessels through differential pressure filling (i.e. the pressure difference between the high pressure land based storage and the lower pressure ship storage causes hydrogen to move between them). This requires a considerable amount of land-based storage (adding cost and complexity) at a pressure of about 500 bar or higher. This is discussed in more detail in Appendix 2.

In this case, the compressor will have a maximum output of 500 bar and a throughput that is slightly higher than the electrolyser – this minimises 20 bar buffer storage required. For the 2MW system proposed here, the throughput would be ~35kg/hr. As the rate of refuelling is dependent on pressure balancing rather than compressor throughput, fast refuelling can be achieved.

The choice of which method is selected is largely a trade-off between cost and refuelling speed. Ship operators will usually request the fastest refuelling times possible and the least disruption to their existing timetables, but this is invariably not the lowest cost solution.

Direct Compression into Ship	Refuelling via pressure differential
No high pressure storage	Lower cost compressor Faster refuel times

Table 4. Summary of the advantages of two refuelling methods

Thus, the compressor specification depends on a variety of factors. As with the buffer storage, ITM have taken the approach of requesting a series of quotations for different suppliers that cover both options and allow a customer’s unit to be accurately specified.

Within the range of compressors studied here, all are skid mounted and capable of being housed in a 20’ ISO container, which will also contain the control equipment and safety sensors. The compressor will be equipped with an inverter on the motor, so that when the electrolyser has reduced output (due to less than maximum RE input), the compressor will also slow its throughput to minimise the on-off cycles and hence pressure cycles of the buffer tank⁶.

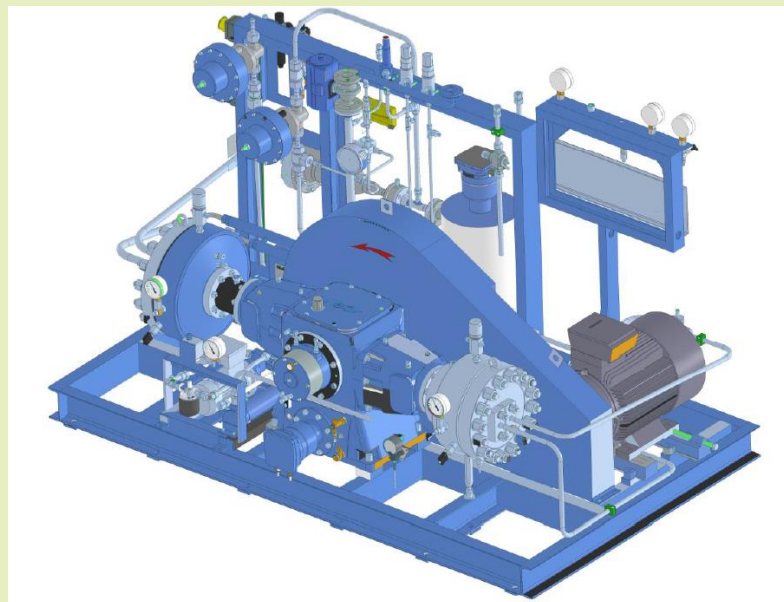

Figure 9: Example CAD of the two stage diaphragm compressor

4.4.5.2 Safety

Preventing over-pressurisation:

On the high pressure side of the compressor, the system contains multiple pressure transducers and pressure relief valves. These will prevent and relieve any over pressure.

Preventing back flow to low pressure system:

Back flow from the high pressure system leading to over pressurisation of the low pressure system is a theoretical risk. This prevented with check valves and a combination of pressure transducers

⁶ Fatigue caused by pressure cycling is something that has to be considered when specifying hydrogen storage vessels

De-carbonising port business today

and pressure relief valves to detect and relieve any back flow from the compressor. In addition, upstream equipment (buffer tank and electrolyser) include pressure relieve valves to prevent over pressurisation.

Detecting diaphragm failure:

Sensors are present between the diaphragms to detect and shut down in the event of a diaphragm failure.

4.4.5.3 Painting

The compressor container will be painted in anti-corrosion paint to marine grade standard.

4.4.6 High Pressure Storage

4.4.6.1 General

As described in Section 4.4.5, high pressure storage is optional, but allows for faster refuels. While there are 4 main 'Types' of storage available, at the pressures discussed here, generally Type 1 steel cylinders are the lowest cost solution. These come in two distinct formats:

- Multiple Cylinder Packs (MCP). These are bundles racks of usually 50L cylinders that are manifolded together. An example is given in Figure 10. While 50L are a mass produced size of cylinder and hence the lowest price, there is a cost associated with fabricating the frame to hold the cylinders and then manifold all of the piping from the individual cylinders together. They also have the disadvantage that at regular intervals (approximately every 5 years), the tubes require internal inspections. If hundreds of tubes are present, this will not be a low cost solution.



Figure 10. An example of an MCP

DUAL Ports

De-carbonising port business today

- A low number of large tubes. These are often up to 0.5m diameter and 10m radius. While these are made in low numbers there is less fabrication and manifolding cost and lower on-going inspection costs. An example is shown in Figure 11.



Figure 11. An example of large tubes.

The cost difference of the two options is small and the choice of which one often comes down to site restrictions which affect the layout of equipment.

4.4.6.2 Control

Redundant pressure transducers on the storage will provide feedback the compressor, and valves, including a restrictor, control the flow to the dispenser.

4.4.6.3 Safety

In addition to the aforementioned pressure transducers (which contain a 'high' alarm), each vessel contains two pressure relief valves. These are arranged with a 3-way valve connection to the tank, so that in normal operation both are in use, but for maintenance, each one can be isolated and removed for calibration without needing to vent the buffer tank. With this arrangement, it is not possible for the vessel to be left accidentally isolated from both valves.

4.4.6.4 Painting

The tubes will be painted in anti-corrosion paint to marine grade standard.

4.4.7 Dispenser

The design of dispenser needs careful consideration. For most vehicles that ITM have experience of refuelling, a key requirement is that the vehicle is stationary before refuelling commences. Due

DUAL Ports

De-carbonising port business today

to both the tides and the swell, there is always vertical movement of the ship. As such the following considerations have been made:

- Automatic / manual connection. A manual connection, as one would find on a bus or train refueller, requires an operator to physically attach the dispenser to the ship. For an automatic system the nozzle is controlled on the end of an XYZ robot arm. Once the nozzle is close to the receptacle, it grabs the nozzle, pulling it in to make a positive connection. It was considered that while 'automatic' may be suitable for large LH₂ vessels, where a long, heavy hose is required, for the smaller gaseous hydrogen ships considered here, a manual connection using proven connection methods is more appropriate.
- Two styles of 350 bar nozzle available, which are shown in Figure 12 and Figure 13.



Figure 12. First style of nozzle, designed for one handed operation



Figure 13. Second style of nozzle requiring two handed operation

While the one handed operation of the nozzle in Figure 12 is easier to use, it is considered that this is very similar to car refuelling nozzles and the style in Figure 13 would be more familiar to ships' crews. Therefore this has been taken forwards.

- Communication between the ship and the refueller is important. As detailed in Section 2, if the filling is undertaken too fast, then the heat of adiabatic compression has the potential to cause the catastrophic failure of the ship's hydrogen storage. Therefore a design of nozzle has been selected that includes an infrared transmitter and receiver, to allow it to communicate with the receptacle so that the refueller can cease the flow if the ship's storage gets too hot.
- To allow for the varying height of different ships and the vertical movement previously discussed, the nozzle will hang from a retractable hose fixed to a rigid arm that can extend over the ship. For whatever reason, if the ship should move further than the length hose at maximum extension, the system includes a 'break-away coupling' – a device that will separate two halves of the hose in the controlled manner, while sealing each end and preventing the release of hydrogen.

DUAL Ports

De-carbonising port business today

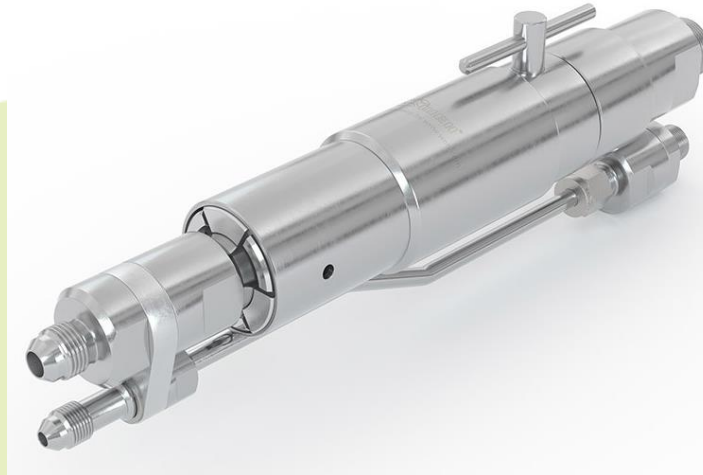

Figure 14. Example of a breakaway coupling

4.5 Tube Trailer Connection Point

Although not required in the standard design, accepting tube trailer delivery will greatly help to achieve customer's availability targets, discussed further in Section 4.6.

The tube trailer connection point will include the following features:

- Designed to accept hydrogen from either 20' or 40' tube trailers
- Safety features detailed below

4.5.1 Safety

The tube trailer connection contains many safety features:

- The connection point contains an 8 bar air supply to connect to a pneumatic isolation valve on the trailer. The supply of air to this valve can be controlled by ITM, allowing hydrogen to be isolated at the tube trailer, rather than at the gas panel. Assuming this tube trailer accepts a pneumatic connection, this brings several safety benefits:
 - The air line will be shorter than the hydrogen line, so if the trailer rolls away, the air line will fail first, isolating the trailer
 - The air line is made from nylon, and will fail quickly at high temperatures, isolating the tube trailer in the event of a fire
 - The refuelling station can isolate the trailer if an unsafe situation is detected on the site (eg. fire or H₂ leak)
 - On connecting the trailer, and the operator pressing 'start', the bunkering system will close the pneumatic valve and pressurise the hydrogen line, then close a valve behind it, trapping the hydrogen. The line will then be monitored using a pressure transducer. If the hydrogen hose has not been connected correctly, or another leak is detected, the pneumatic valve will remain sealed and prevent further filling from the trailer. Otherwise, the pneumatic valve will be opened and filling can commence.

De-carbonising port business today

- A pressure transducer monitors the lines, detecting leaks
- A pressure relief valve to prevent downstream equipment over pressurising.

4.5.2 Painting

The tubes will be painted in anti-corrosion paint to marine grade standard.

4.6 Methods to Achieve High Availability

Boat operators will expect the bunkering system to have a high availability – likely to be in excess of 99%. The three things that will result in not being able to refuel ships are:

1. Insufficient input power due to the unreliability of renewable sources of power. This has been discussed in detail in Appendix 1, but in summary, allowing some topping up from the grid substantially reduces the amount of backup storage required.
2. Planned maintenance. It is estimated that ~2 weeks per year of planned maintenance is required on the bunkering system. This immediately drops the availability below 99%, so a method of planning maintenance around a working system is required.
3. Unplanned maintenance. While all of the equipment specified is commercially available, it would be naïve to think that unexpected failures will not occur.

Various approaches described below have been considered to achieve the high availability, each will have a cost and effect on the system up-time. The method selected will therefore need to be made in consultation with the customer to understand their availability vs price sensitivity.

4.6.1 Total Redundancy

The replication of all equipment will have a significant positive effect on the downtime as a fraction of the year⁷, however, this is also the most expensive option, immediately doubling the price of the system

4.6.2 Redundancy of Selected Components

There is little point in replicating storage, as it doesn't fail in normal use. While the electrolyser could be replicated, a lower cost option would be to provide a tube trailer connection point, which will allow hydrogen to be delivered to site until the electrolyser is back on line. Thus, redundancy is only required for the compressor and the dispensing point.

⁷ It will square the fraction of downtime, so if the system is normally unavailable for 5% of the time, then the effect of replication will be $0.05^2 = 0.25\%$ (assuming completely independent systems with no common cause failures).

DUAL Ports

De-carbonising port business today

4.6.3 High Pressure Hydrogen Storage

While hydrogen storage can be a solution for lack of RE power to the system (as discussed in Appendix 1), if refuelling by differential pressure is utilised, it can ensure that the availability continues to be high, irrespective of the failure of upstream equipment. However, sufficient storage is required so that operation can continue until the component is repaired. If a replacement part has a lead time of several weeks, this could represent a very large amount of hydrogen storage.

4.6.4 Local Stock of Spare Parts

A recommended spare parts list has been drawn up. The problem is knowing when to stock a part and when not to. For complete cover, every spare part should be stocked, but this is equivalent in cost to the customer of a completely redundant system. Therefore, components that are low cost with long lead times have been focussed on, where having a spare supply on site can result in a significant reduction in lead time. However, whatever system is used to try and determine the most efficient parts to stock, it would be typical that the part to fail is not one that was selected. Therefore, while being a good method at improving availability, it should be used in conjunction with other methods.

4.7 Proposed Layouts

The general system that has been designed and described here can therefore be significantly changed, depending on the customers' requirements. Renders of a proposed layout for a 2MW system is presented in Figure 15. While Figure 16 and Figure 17 show a concept for a 50MW system that would be more suited to an international port.



Figure 15. Concept render of a 2MW hydrogen bunkering system

DUAL Ports

De-carbonising port business today

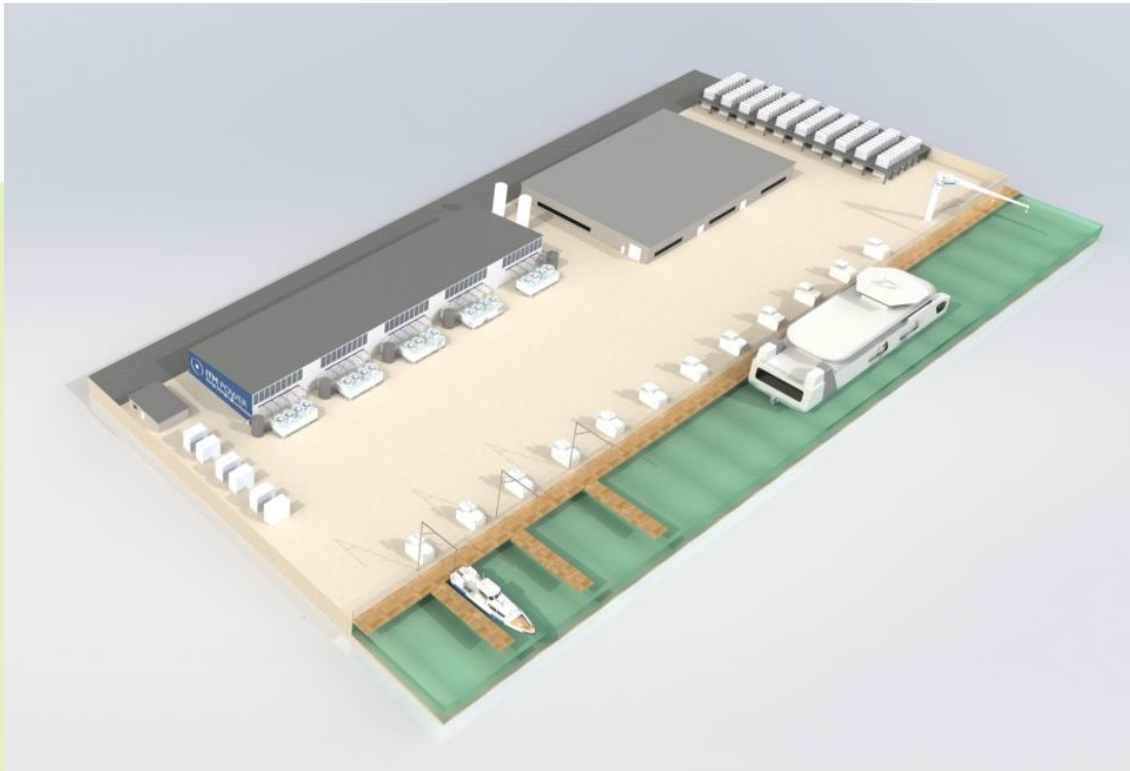

Figure 16. Concept render of a 50MW hydrogen bunkering system



Figure 17. Concept render of a 50MW hydrogen bunkering system within a wider port

De-carbonising port business today

5 Application of the Design to the Orkney Islands

5.1 Hydrogen Demand

The DUAL Ports project requires that the general design that was detailed in Section 4 is applied to the specific case of Orkney, and the business case of each is examined. As discussed in Section 2, it is highly likely that a hydrogen ferry is coming to Orkney:

A hydrogen fuel cell ferry to operate the route between Kirkwall and Shapinsay (7km distance with 12 crossings per day [14]). The ship is not yet fully designed, but ITM believe it to be have 350 bar storage. To calculate the likely hydrogen consumption, the present diesel vessels annual fuel consumption is 176,610 L [14]. Based on a diesel energy density of 37.2 MJ/L [15], this equates to 6,570 GJ of energy. The engines on the present ferry are old, with an estimated thermal efficiency of 41% [14], suggesting 2,693 GJ of propulsion per year. With a 45% efficient fuel cell, the hydrogen consumption would be 5,985 GJ/yr. This is equivalent to 1,662,500 kWh/yr. With hydrogen having a lower heating value of 33.3 kWh/kg⁸, this requires 50 tpa of hydrogen, or a daily supply of **137kg**.

ITM have been advised that the ferry operators do not wish to purchase and maintain bunkering equipment, but instead wish to continue their present model of a third party installing the equipment and they simply pay for the fuel. They will thus issue a commercial tender for whichever company can offer them the lowest price per kg for hydrogen.

Four options will be explored for meeting this:

- Generate hydrogen on Shapinsay, transport by tube trailer and fast fill of ferry in Kirkwall
- Generate hydrogen on Shapinsay, transport by tube trailer and slow fill of ferry on Shapinsay
- Generate hydrogen on Shapinsay, transport by pipeline at 200bar and slow fill of ferry on Shapinsay
- Generate hydrogen at a new site on Shapinsay, transport by pipeline at 350 bar and slow fill of ferry on Shapinsay

5.2 Existing Hydrogen Equipment in Orkney

ITM and its partners already have a variety of equipment in Orkney, which can be utilised to supply the required demand:

⁸ A debate could be entered into about whether the lower heating value or higher heating value is more appropriate for fuel cells. The choice depends on what happens to the water produced in the reaction. If left as a vapour, the lower heating value is used. If condensed, the higher heating value is used. Unfortunately, in a fuel cell some will be condensed and some will remain as vapour. For simplicity the lower value has been used.

DUAL Ports

De-carbonising port business today

5.2.1 On Shapinsay:

- 1MW electrolyser capable of generating 400kg/day (if operated continuously) of 20 bar fuel cell grade hydrogen
- Hydrogen compressor capable of 15 to 200 bar at >400 kg/day throughput
- 2m³ buffer storage capable of operating at 20 bar
- 2x tube trailer connection points

5.2.2 On Eday:

- 0.5MW electrolyser capable of generating 200kg/day (if operated continuously) of 20 bar fuel cell grade hydrogen
- Hydrogen compressor capable of 15 to 200 bar at >200 kg/day throughput
- 1.5m³ buffer storage capable of operating at 20 bar
- 500kg of 200bar hydrogen storage
- 1x tube trailer connection points

5.2.3 Operating between Eday, Mainland and Shapinsay

- 5x tube trailers, able to transport 250kg of 200 bar hydrogen

5.3 Harbour Equipment for Fast Filling of Ferry in Kirkwall

Section 4 described the detail of all of the system components, and how each of them could be scaled for any requirement, so that description will not be repeated here. Instead, this section will focus on the specification of individual components.

5.3.1 Assumptions:

As described, the system cost varies strongly with the refuelling profile of the vessel and its hydrogen refuelling requirements. Very little information is available to ITM about such details, therefore some assumptions have been made. It is acknowledged that a consequence of this is that the final price may not necessarily match the final ferry design and how it will be operated, but it will provide a budgetary number that can be subsequently refined. In addition, it demonstrates how ITM will calculate the specification for any given customer. The assumptions are:

- The ferry will 'fast fill' which is assumed to mean that it will refuel 137kg in 1hr.
- For emergencies the ferry will need to have additional 80% on-board storage, suggesting a total hydrogen storage of 246 kg. However, as this will only be used in emergencies, it is assumed that although the bunkering station must have the capacity to deliver 246kg, it only needs to fill 137kg in 1hr and the additional 110kg of storage will require a further 48 mins.
- Storage on the vessel will be at 350bar
- Hydrogen generation will not be located in Kirkwall (on the island of Mainland) as:

De-carbonising port business today

- There is minimal electricity curtailment in Kirkwall so the power source will either need to be the grid or a new wind turbine specifically dedicated to this project. Either way, the turbine will need to be built away from the harbour and either a hydrogen pipe or power cable taken through Kirkwall. This is likely to be prohibitively expensive.
- ITM has no hydrogen generation equipment on Mainland, whereas it would be desired to reduce cap-ex by leveraging as much existing equipment as possible.

As such, hydrogen will be generated on Shapinsay and transported to Kirkwall on tube trailers via the hydrogen ferry. This route is shown in Figure 18

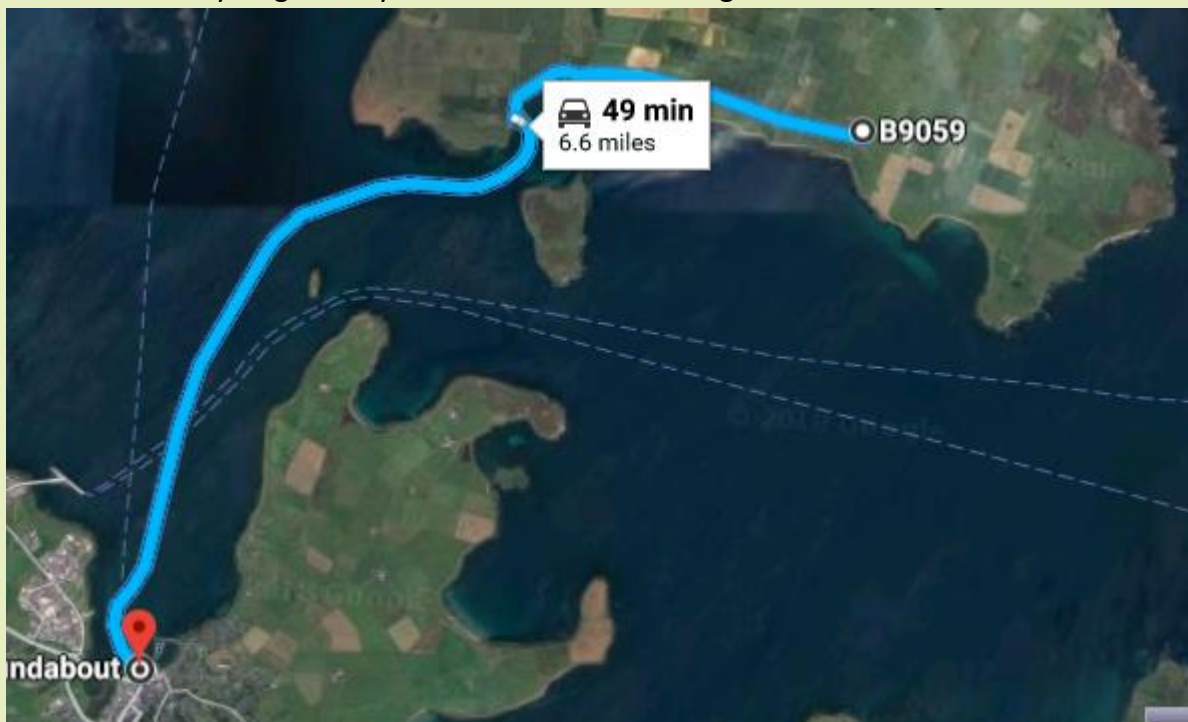

Figure 18. Route of the tube trailer from the generation site on Shapinsay to Kirkwall Harbour

5.3.2 Harbour Equipment Option 1: Compress from Tube Trailers

- The trailers come to the harbour and connect to the tube trailer connection point and remain connected as local storage
- When refuelling is required, high capacity compressors transfer hydrogen from the compressor directly into the vessel. Three compressors will be used, with 2 being required to meet normal operation and 1 being redundant. Even if two compressors fail, the ferry will still be able to refuel, but will take 2 hours.
- No local storage has been provided to cover times of bad weather when hydrogen cannot be delivered from Shapinsay, as if the ferry is not operating, then no hydrogen will be required to fuel it.

De-carbonising port business today

- Hydrogen is dispensed via a high flow nozzle supported on an arm over the vessel

The harbour equipment is summarised below in Table 5.

Parameter	Value	Comment
Number of tube trailer connection points	3	Two for connection of trailers, one for redundancy
Number of compressors	3	2 required to meet the flow rate, 1 for redundancy
Minimum compressor input	20 bar	
Maximum compressor output	350 bar	
Compressor throughput	68kg/hr	
Number of dispensers	2	Includes one for redundancy
Dispenser	0.12kg/sec	Includes nozzle, hose and supporting arm
Permanent storage on site	0kg	The only storage is via removable tube trailers.
Availability	>99%	
Warranty	12 months	Covers all planned and unplanned maintenance, including parts, labour and travel.
Delivery cost per tube trailer	€335k	ITM have undertaken a tender exercise to establish the pricing for these journeys
Budgetary Price for harbour equipment (not generation or transport)	€1.35m	Includes equipment, delivery and commissioning. Excludes civil works.

Table 5. Option 1 summary of equipment for fast filling at Kirkwall Harbour, including full redundancy

5.3.3 Harbour Equipment Option 2: Cascade fill from Static Storage

- The trailers come to the harbour and connect to the tube trailer connection point
- A compressor transfers the hydrogen into 500 bar storage over a period of 8 hours. A second compressor is added for redundancy
- No local storage has been provided to cover times of bad weather when hydrogen cannot be delivered from Shapinsay, as if the ferry is not operating, then no hydrogen will be required to fuel it.

The harbour equipment is summarised below in Table 6.

De-carbonising port business today

Parameter	Value	Comment
Number of tube trailer connection points	3	Two for operation, one for redundancy
Number of compressors	2	One required to meet the flow rate, 1 for redundancy
Minimum compressor input	20 bar	
Maximum compressor output	350 bar	
Compressor throughput	17kg/hr	
Number of dispensers	2	Includes one for redundancy
Dispenser	0.12kg/sec	Includes nozzle, hose and supporting arm
Permanent storage on site	700kg	500bar storage
Availability	>99%	
Warranty	12 months	Covers all planned and unplanned maintenance, including parts, labour and travel.
Delivery cost per tube trailer	€335k	ITM have undertaken a tender exercise to establish the pricing for these journeys
Budgetary Price	€1.55m	Includes equipment, delivery and commissioning. Excludes civil works.

Table 6. Option 2 summary of equipment for fast fill at Kirkwall Harbour, including full redundancy

5.3.4 Fast Filling at Kirkwall Harbour Conclusion

If fast filling is required, it is recommended to go with Option 1 (compress into vessel directly from tube trailers), as it is lower cost, will have a smaller footprint and have no permanent storage on site, considerably reducing the hazard.

5.4 Harbour Equipment for Slow Filling the Ferry in Shapinsay

The following assumptions have been made

- The ferry will 'slow fill' which is assumed to mean that it will refuel 137kg overnight (8hrs).
- For emergencies the ferry will need to have additional 80% on-board storage, suggesting a total hydrogen storage of 246 kg. However, as this will only be used in emergencies, it is assumed that although the bunkering station must have the capacity to deliver 246kg, it only needs to fill 137kg in 1hr and the additional 110kg of storage will require a further 48 mins.
- Storage on the vessel will be at 350bar
- Hydrogen generation will be located ~2.2 miles (3.4 km) from the harbour at the existing generation site and transported to the harbour either by tube trailer or underground pipeline. See Figure 19.

DUAL Ports

De-carbonising port business today

- Once hydrogen is on-site, it will be transferred to the ferry in 8 hrs via a 20 bar to 350 bar compressor.

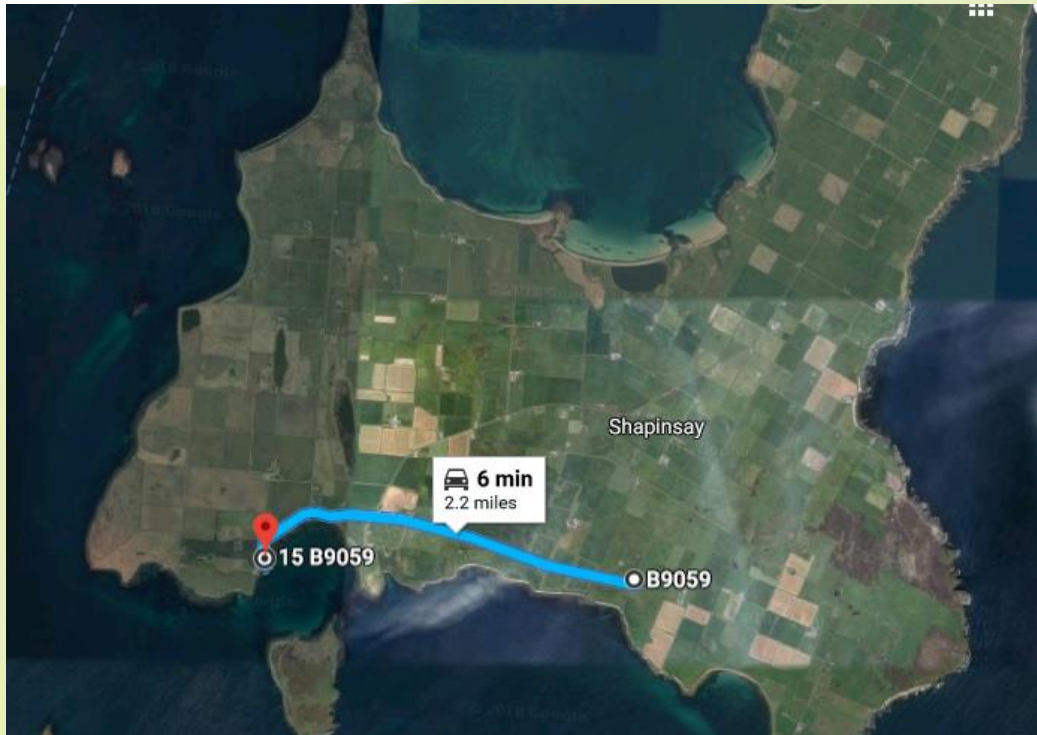

Figure 19. Satellite view of Shapinsay showing the harbour (red marker) and the community wind turbine.

The two options of either underground pipeline or tube trailer have been explored in Options 1 and 2.

5.4.1 Option1: Tube Trailer Deliveries

The equipment required is summarised in Table 7.

Parameter	Value	Comment
Number of tube trailer connection points	2	One for operation, one for redundancy
Number of compressors	2	1 required to meet the flow rate, 1 for redundancy
Minimum compressor input	20 bar	
Maximum compressor output	350 bar	
Compressor throughput	17kg/hr	
Number of dispensers	2	Includes one for redundancy
Dispenser	0.12kg/sec	Includes nozzle, hose and supporting arm
Permanent storage on site	0kg	Although bad weather will prevent drivers coming to the island to move trailers to site, it will also mean that the ferry will not require any fuel.
Availability	>99%	
Warranty	12 months	Covers all planned and unplanned maintenance, including parts, labour and travel.

De-carbonising port business today

Delivery cost per tube trailer	€300	ITM have undertaken a tender exercise to establish the pricing for these journeys
Budgetary Price	€1.35m	Includes equipment, delivery and commissioning. Excludes civil works.

Table 7. Option 1 summary of equipment for slow fill at Shapinsay Harbour, including full redundancy

5.4.2 Option2: Pipeline to Harbour

The equipment required is summarised in Table 8.

Parameter	Value	Comment
Number of tube trailer connection points	0	Pipeline removes the need for connection points
Length of pipeline	3.5 km	ITM have sought quotes from civil engineering companies for the cost of the trenching required (to the standards required) and to companies who can supply the welded high pressure pipe work).
Number of compressors	2	1 required to meet the flow rate, 1 for redundancy
Minimum compressor input	200 bar	A 200 bar output compressor is already present at the Shapinsay hydrogen generation site. This is a suitable pressure to transfer the hydrogen and means that a lower cost compressor can be used.
Maximum compressor output	350 bar	
Compressor throughput	17kg/hr	
Number of dispensers	2	Includes one for redundancy
Dispenser	0.12kg/sec	Includes nozzle, hose and supporting arm
Permanent storage on site	0kg	None required
Availability	>99%	
Warranty	12 months	Covers all planned and unplanned maintenance, including parts, labour and travel.
Delivery cost of hydrogen	€0	The presence of a pipeline means that transport costs are zero.
Budgetary Price	€2.2m	Includes equipment, hydrogen pipework, delivery and commissioning. Excludes civil works.

Table 8. Option 2 summary of equipment for slow fill at Shapinsay Harbour, including full redundancy

5.4.3 Slow Fill at Shapinsay Harbour Conclusion

Although the cost of the pipeline is significant, the zero priced transport means that the cost over life could be lower. Both will be taken forward for consideration in Section 6, the study of the business cases for each option.

5.5 Hydrogen Generation at Existing Site

All of the sites and methods of bunkering considered above, can be supplied with hydrogen from the existing BIG HIT equipment located on Shapinsay, but with the site expanded with a second wind turbine, electrolyser, compressor and storage. The details of which are provided in this section.

DUAL Ports

De-carbonising port business today

5.5.1 Wind Turbine

There is an assumption in the following calculations that the ferry operator will specify that the hydrogen will need to be produced from low carbon (but not zero carbon⁹) sources. The demand of 135 kg/day equates to a requirement of 49t/yr. Separate modelling [16] under the BIG HIT project has predicted that 25t/yr of hydrogen could be produced from the available curtailed energy, however, this is limited within BIG HIT as production has to cease when all storage is full.

For the foreseeable future, BIG HIT will require 12t/yr, meaning only 13t/yr, or 35 kg/day will be available for refuelling the ferry, far short of the required level. It is not possible to use uncurtailed wind energy to power the electrolyser as the wind turbine owners (Shapinsay Development Trust) have an existing Power Purchase Agreement (PPA) which would prevent them selling their power to anyone else.

As a moratorium on new renewable grid connections has been imposed in Orkney, a new renewable generator will need to be off-grid and have its output dedicated to the electrolyser. An additional production of 37t H₂ /yr will require 2.1GWh/yr of electrical energy. At a 30% capacity factor, it will require a turbine with 7.0 GWh/yr of potential production, which is equivalent to a 802 kW output turbine. As the existing 900kW Enercon turbine is already on site, with known annual output and installation costs, this will be used.

5.5.2 Electrolyser

A 1.0 MW electrolyser has been specified for this scenario and is described in Table 9. This will be set to operate with respect to a maximum fixed power input rather than a fixed maximum gas output; hence, as the system ages and becomes less efficient, it will still require a maximum of 1.0MW, but with less gas output. As such, when new, it will be slightly oversized for the task.

⁹ This will force the electrolyser to use predominantly renewable power, but allow the use of grid power for when the wind isn't available. See Appendix 1 for further discussion on this point.

Parameter	Value
Number of Electrolyser Stacks	2
Stack platform	MEP
Maximum Hydrogen Production (new) (kg/day)	427
Maximum Hydrogen Production (EoL) (kg/day) ¹⁰	345
Max Power Requirement (kW)	1000
Water Consumption (litres/kg H ₂) ¹¹	28.1
Electrolyser Operating Pressure (bar)	20
Electrolyser Efficiency at Max Output (new) (kWh/kg)	56.3
Electrolyser Efficiency at Max Output (EoL) (kWh/kg)	69.4
Electrolyser Peak Efficiency (new) (kWh/kg)	51.1
Electrolyser Peak Efficiency (EoL) (kWh/kg)	57.7
Load Control	27 - 100%
Cold Start Time (s)	300
Warm Start Time (s)	30
Modulation(sec)	2 (max)
Hydrogen Purity	99.995% - ISO 14687-2:2012
Packaging	20' + 20' Containers
Temperature Range (C) ¹²	-15 to +35. 15C average.
Power Supply	11kVAC, 3 phase, 50 Hz
Control	PLC
Warranty Period	12 months

Table 9. Summary of electrolyser specification

A key feature to understand is how the electrolyser system efficiency will change with varying input from the turbine. This has been modelled and is presented in Figure 20. Note the unusual shape of the efficiency curve, where high efficiency is a low point on the curve (ie low kWh for every kg of hydrogen produced). The curve has a maximum efficiency at 31% of max power (301kW), which is very similar to the expected average usage of the electrolyser.

¹⁰ EoL = End of Life

¹¹ Including the anticipated rejection rate from the water purification system.

¹² Considered appropriate for outdoor use together with internal thermal controls.

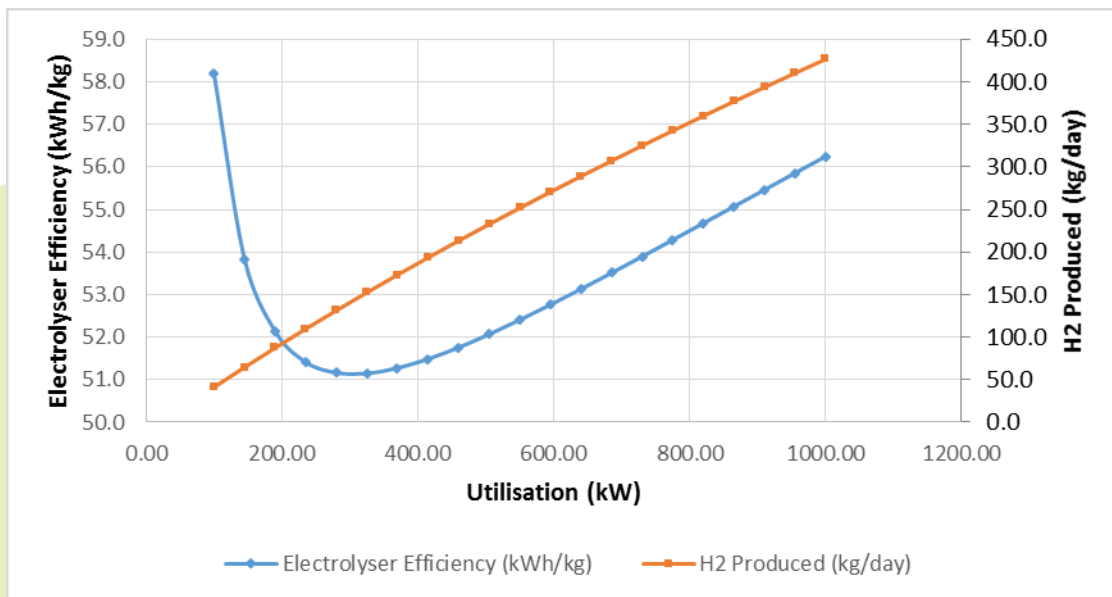

Figure 20. The variation of efficiency and hydrogen production with electrical input to the electrolyser

In theory the hydrogen production over a year should be greater than the ferry demand. However, as discussed in detail in Appendix 1, the daily production will not match demand, and buffering the production to ensure supply will be too expensive. It is suggested that the grid is used to top up production in times of low wind, particularly as the grid in Orkney has a low carbon intensity, but with 500kg of storage to try and reduce the grid requirement, as well as provide additional benefits detailed below.

5.5.3 Storage

As the turbine output is not smooth and continuous, storage is required to ensure that 100kg/day is produced. Based on conducting a similar analysis to that shown in Appendix 1, ITM have modelled the scenario where all of the turbine’s output is directed to the electrolyser, but grid power (priced at €110/MWh) is utilised when the storage is empty. This significantly reduces the amount of storage required, but at the expense of paying for grid electricity. The cost over life including the cost of storage and the total electricity cost over the expected 20 years of operation was calculated for a range of storage quantities. This is shown in Figure 21.

DUAL Ports

De-carbonising port business today

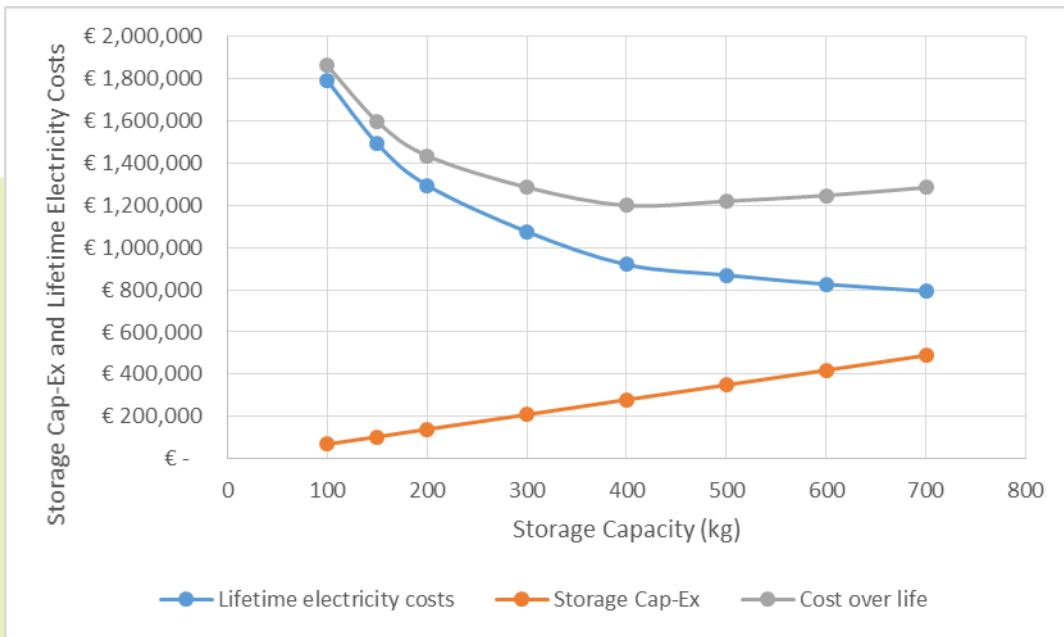

Figure 21. Plotting the lifetime electricity costs and storage cap-ex to identify the lowest cost over life

This shows that a storage of 400kg provides the lowest lifetime electricity costs and storage cap-ex to provide a continuous output of 100kg/day. The storage level variation throughout the year is shown in Figure 22.

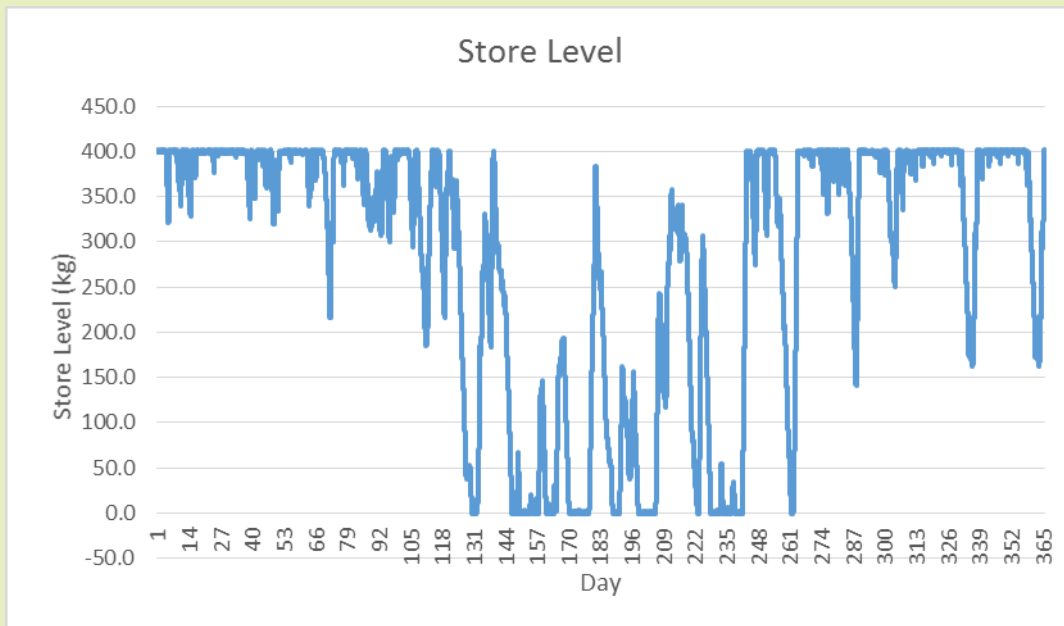

Figure 22. The store level variation throughout the year.

However, there is a question about how this should be stored.

- If stored at the electrolyser output pressure of 20 bar, then the compressor has a minimum input of 10 bar so can only access half of the storage, meaning that 800kg will be required.

De-carbonising port business today

- If stored at the compressor output of 200bar, then:
 - If a pipeline is used to transport the fuel to Shapinsay harbour, the compressor at the harbour has a minimum input of 20 bar, thus the hydrogen will need compressing into the pipeline where generated via the compressor. This compressor can only access down to 10bar, meaning only 5% is inaccessible, so 420kg of total static hydrogen storage will be required.

It may be considered that an additional compressor is required as if it's being used to pump from the reserve storage into the pipeline, it cannot be taking hydrogen from the electrolyser buffer tank. However, the reserve will only be used when the electrolyser is not operational due to low wind, and therefore this is not a concern.

- If a tube trailer is selected to transport the hydrogen between the generation site and either Shapinsay or Kirkwall harbour, then two options are available:
 - If static storage is selected, then the tube trailers can be filled via cascade until they level out at the same pressure (modelling suggests this will be 123bar). After that, the compressor will need to draw from the storage to fill the tube trailers. This will cost ~€4.1k pa, or €83k over the 20 year lifetime, in additional electrical energy to compress the hydrogen a second time.
 - It would be more efficient (as the compressor is not compressing the same gas twice to 200 bar) but more expensive to have the reserve storage as spare tube trailers. When required, they can simply be taken from site and swapped for a new trailer. Quotes have been obtained and it is expected to be €80.4k more expensive to have mobile rather than static storage

As the price of the two options is almost identical, it is recommended to go for the static storage as the maintenance of the static storage will be considerably less than the mobile storage, which will require annual ADR inspections.

5.5.4 Compressor and Buffer Storage

If both the existing and new electrolysers can produce ~800kg/day if provided with a continuous electrical input and the existing 10 to 200 bar compressor is only capable of ~440kg/day of throughput, a second compressor would appear to be required for normal operation. However, the existing compressor presently has an average throughput of 65kg/day, so there will be considerable spare capacity for the average 100kg/day that the second electrolyser is required to produce.

Thus, one option is rather than purchase a second compressor, to expand the existing 20 bar buffer storage to ensure that when the new electrolyser and the existing electrolyser are both operating with a combined production of >440kg/day, then the hydrogen can be stored until needed. The size of the store has been modelled in detail, based on the pressure not going below 10 bar (the minimum compressor input), as shown in Figure 23.

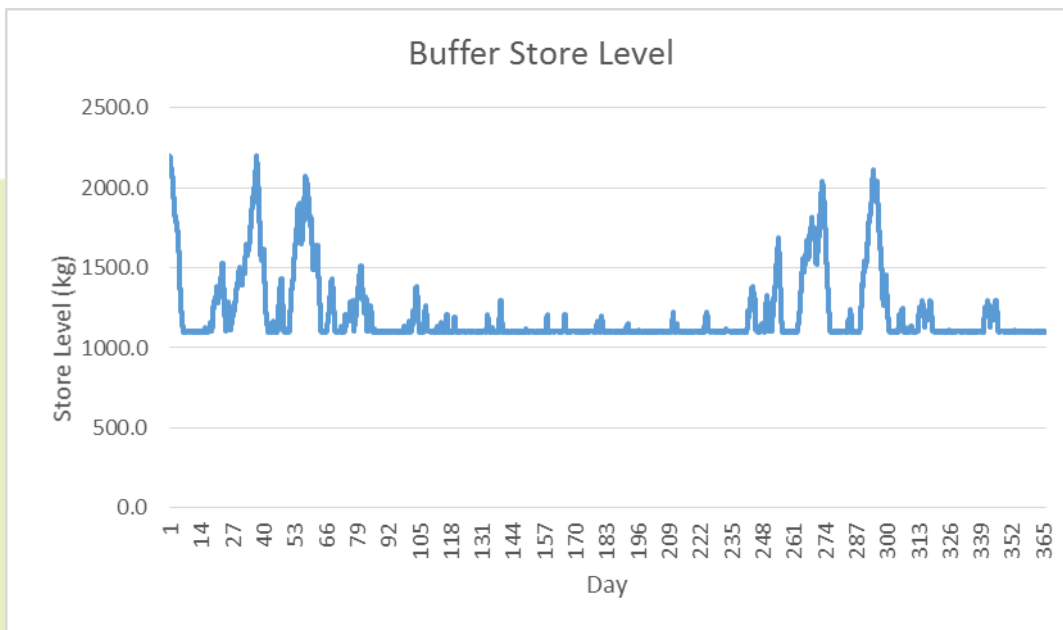

Figure 23. The buffer store level required to prevent the need for an additional compressor

As can be seen, a buffer store level of 2,200 kg, with a cost of ~€1.8m, is required to prevent the need for an additional compressor. This is not sensible, therefore a second compressor dedicated to the new electrolyser is required.

5.5.5 Tube Trailer Connection Points

If hydrogen will be delivered via tube trailer, modelling suggests that the two existing connection points will be sufficient; however, a third will be added to provide redundancy.

5.5.6 Approach to Achieve >99% Availability

Consideration has been given as to how best to achieve the assumed requirement for >99% availability. For the electrolyser and compressor, options include:

1. The approach taken elsewhere in this report is duplication of equipment; however, electrolysers have a relatively high capital cost compared to other system components
2. As previously discussed, there will be 400kg of static storage on site, which when combined with the contents of any tube trailers on or off site, will allow for several days of operation. However, note that the storage is provided for reducing dependence on the grid, therefore it is possible that they will be depleted when needed.
3. ITM has a partner (EMEC, the European Marine Energy Centre) who have a 0.5MW electrolyser and 10 to 200 bar compressor on the nearby island of Eday, with compatible tube trailers, trailer connection points and 500kg of 200 bar storage. Therefore, they would be able to supply hydrogen in the event of a short term failure.

DUAL Ports

De-carbonising port business today

A further consideration is that the site has an existing electrolyser and compressor which, while unable to produce the required throughput on a continuous basis, could step in to cover some short-term need, particularly if grid power could be diverted to it to increase output.

Based on this, Option 3 above (having hydrogen produced on Eday as a backup) should produce the required availability.

5.6 Hydrogen Generated at a new Site, with Pipeline at 350bar to Shapinsay Harbour

The analysis undertaken to date has been based on the premise that the existing equipment for generation and compression will be contributing ~40kg/day towards the hydrogen requirement. While this is useful, it limits the max pressure leaving the site to 200bar, which requires extra compression (and a redundant standby) at the point of refuelling.

An alternative considered in this section is that a new hydrogen generation site with capacity to meet the full 135kg/day is located close to Shapinsay harbour, hydrogen is generated and compressed to 350 bar and then piped to the harbour where it can directly fill the vessel. It is then possible to use the existing sites on Shapinsay and Eday which can deliver 200bar hydrogen via tube trailers to ensure the 99% availability. However, this requires an additional to 350 bar compressor and a tube trailer connection point. However, at the harbour, minimal equipment will be required – simply the dispenser (and a redundant dispenser).

The site is assumed to be south of the village of Balfour, shown in Figure 24.

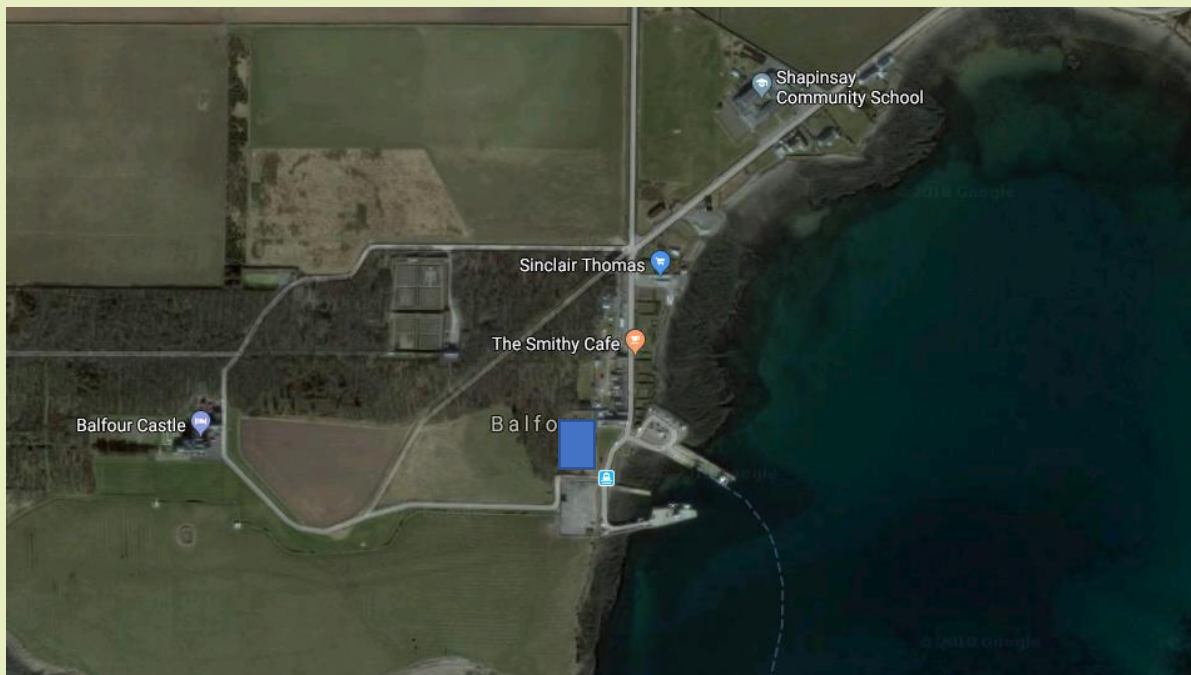

Figure 24. The village of Balfour on Shapinsay, near the harbour, showing the assumed site of the electrolyser

De-carbonising port business today

5.6.1 Wind Turbine

In this scenario, a completely new wind turbine will be required which will need to supply all of the required 135kg/day of hydrogen. Calculations suggest a 1.3MW turbine should be sufficient.

5.6.2 Electrolyser

A 1.3 MW electrolyser has been specified for this scenario and is described in Table 10. This will be set to operate with respect to a maximum fixed power input rather than a fixed maximum gas output; hence, as the system ages and becomes less efficient, it will still pull a maximum of 1.3MW, but with less gas output. As such, when new, it will be slightly oversized for the task.

Parameter	Value
Number of Electrolyser Stacks	2
Stack platform	MEP
Maximum Hydrogen Production (new) (kg/day)	528
Maximum Hydrogen Production (EoL) (kg/day) ¹³	450
Max Power Requirement (kW)	1300
Water Consumption (litres/kg H ₂) ¹⁴	28.1
Electrolyser Operating Pressure (bar)	20
Electrolyser Efficiency at Max Output (new) (kWh/kg)	59.1
Electrolyser Efficiency at Max Output (EoL) (kWh/kg)	69.1
Electrolyser Peak Efficiency (new) (kWh/kg)	52.1
Electrolyser Peak Efficiency (EoL) (kWh/kg)	57.2
Load Control	22 - 100%
Cold Start Time (s)	300
Warm Start Time (s)	30
Modulation(sec)	2 (max)
Hydrogen Purity	99.995% - ISO 14687-2:2012
Packaging	30' + 30' Containers
Temperature Range (C) ¹⁵	-15 to +35. 15C average.
Power Supply	11kVAC, 3 phase, 50 Hz
Control	PLC
Warranty Period	12 months

Table 10. Summary of electrolyser specification

A key feature to understand is how the electrolyser system efficiency will change with varying input from the turbine. This has been modelled and is presented in Figure 25.

¹³ EoL = End of Life

¹⁴ Including the anticipated rejection rate from the water purification system.

¹⁵ Considered appropriate for outdoor use together with internal thermal controls.

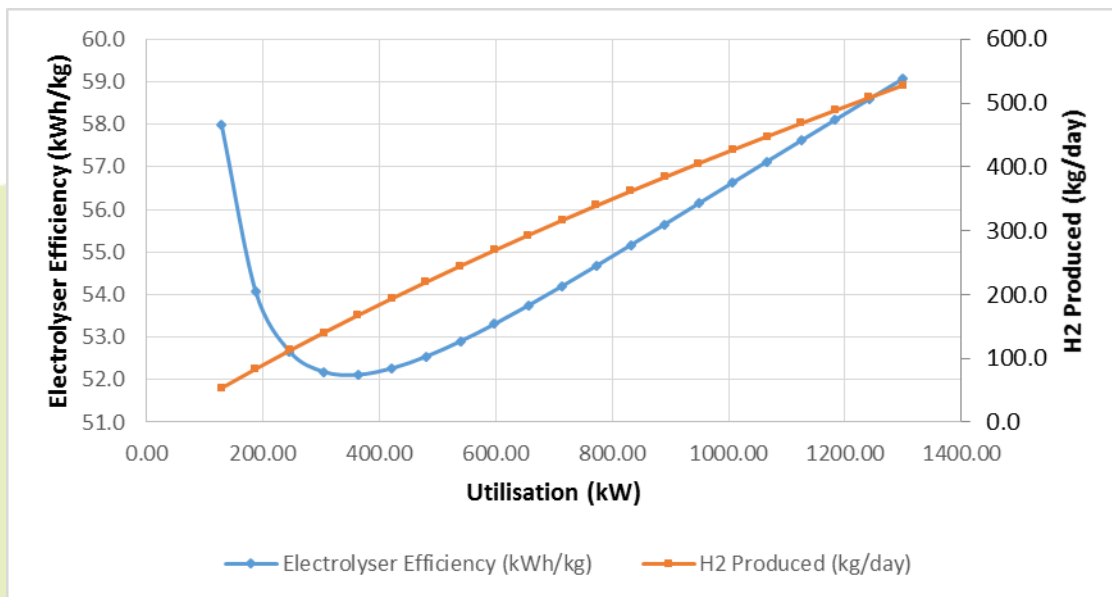

Figure 25. The variation of efficiency and hydrogen production with electrical input to the 1.3 MW electrolyser

5.6.3 Storage

As before, buffer storage will be required to ensure that hydrogen is available irrespective of the wind on a particular day. A modified version of the modelling detailed in Section 5.5.3 was run, which showed a requirement for 577kg of static storage at 350 bar.

5.6.4 Compressor and Buffer Storage

Following the same methodology as detailed in Section 5.5.4, a single compressor was selected with 15 to 350 bar capacity and a maximum throughput of 528kg/day. No low pressure buffer storage will be used for redundancy, and instead a standard 3m³ 20 bar buffer vessel will be used.

5.6.5 Pipeline

The output of the compressor will be fed directly into a 350bar pipeline to Shapinsay harbour. Although a site has not been formally confirmed, the assumption is that it will be to the south of the village of Balfour, and thus a pipeline of ~100m will be required.

5.6.6 Tube Trailer Connection Point

This will allow the connection of 200 bar tube trailers from the electrolyzers in Shapinsay or Eday to provide redundancy.

5.6.7 Approach to Achieve >99% Availability

The approach taken is that if either the electrolyser or compressor fail, then either of the existing sites in Shapinsay or Eday can provide delivered hydrogen to site, which can be compressed to 350bar and piped directly to the vessel. A redundant dispenser is included.

DUAL Ports

De-carbonising port business today

5.6.8 Example Layout Drawings

As has been described above, it is assumed that the hydrogen generation, compression and storage equipment will be located south of the village of Balfour. A pipeline will then deliver the hydrogen to the dispensers located on Shapinsay harbour.

An example of how the equipment could be positioned on this selected location can be seen in Figure 26 and Figure 27.

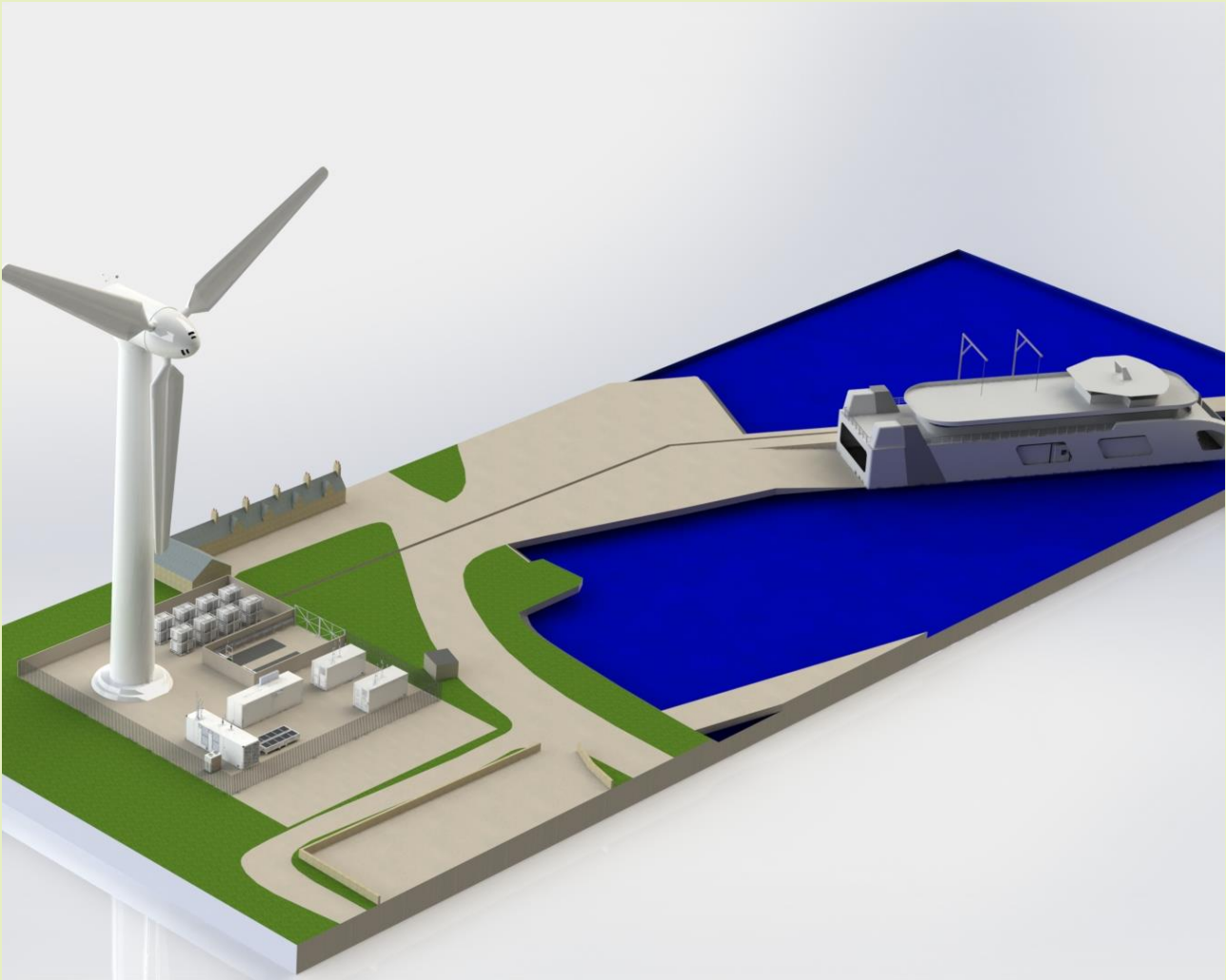

Figure 26 - Example layout of the site containing the site for the hydrogen equipment, pipeline and dispensing equipment on the harbour.

DUAL Ports

De-carbonising port business today



Figure 27 - Close-up view of the electrolyser site, showing the wind turbine, electrolyser, compression equipment, storage vessels and tube trailer connection points.

De-carbonising port business today

6 Business Cases

For both commercial and technological reasons, many of the details within this section cannot be revealed in this public document. However, the background and resulting cashflow has been presented.

The following assumptions have been made:

- Cost of capital: 6%
- Generation feed in tariff (FIT): €0.0247/kWh (correct at the time of writing)
- Euro/£ conversion: €1.15/£

Each case included (where appropriate):

- Capital cost of harbour equipment, excluding civils
- Capital cost of generation equipment (inc turbine), excluding civils
- Capital cost of tube trailers or pipeline
- Maintenance of equipment at the harbour
- Maintenance of equipment at the generation site, including the turbine
- Cost of the haulier to transport the tube trailers
- Cost of ferry crossings, taking account of the extra space required on the desk for AtEx
- Cost of water at the generation site
- Tube trailer maintenance cost
- Incoming electricity cost for topping up generation at times of low wind
- The generation FIT for the new turbine
- The H₂ sale price to Orkney Ferries

However, each case does not include:

- Civil works

6.1 Fast Filling at Kirkwall Harbour

Based on the system described in Section 5.3, the cashflow for a hydrogen price between €1/kg and €10/kg is shown in Figure 28.

DUAL Ports

De-carbonising port business today

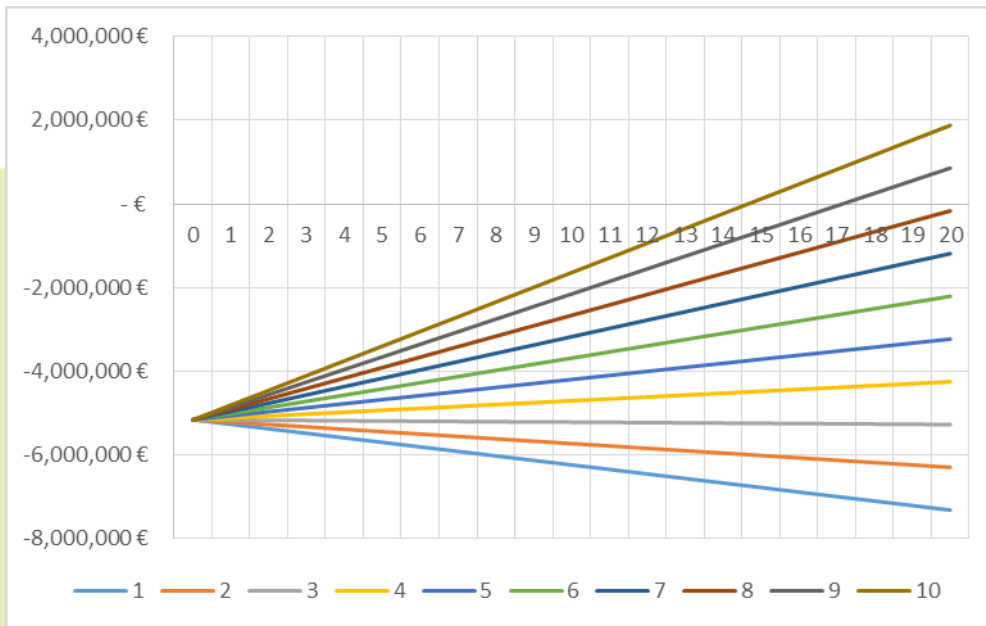

Figure 28. The modelled cashflow for fast filling in Kirkwall for a range of hydrogen sale prices (€/kg)

This indicates that breakeven at €10/kg can only be achieved by yr 14.

The breakdown of income and expenditure for this scenario is shown in Figure 29.

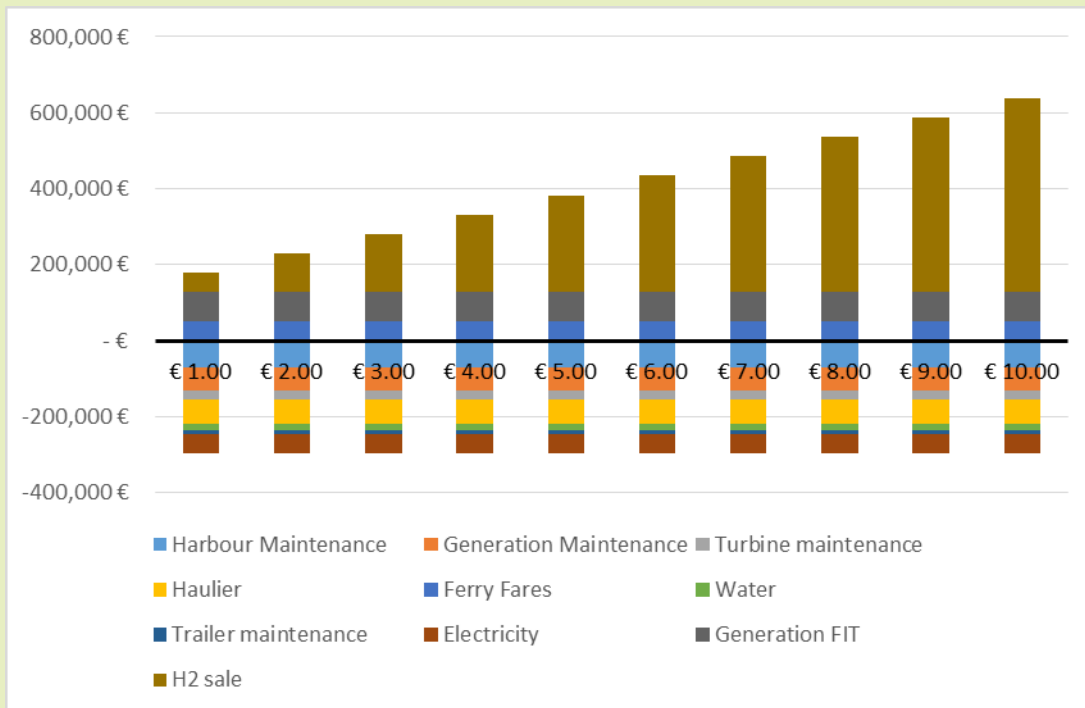

Figure 29. Breakdown of income and expenditure for fast filling at Kirkwall for a range of hydrogen sale prices (€/kg).

DUAL Ports

De-carbonising port business today

6.2 Slow Filling at Shapinsay via Tube Trailer Deliveries

Slow filling at Shapinsay was expected to be lower cost than fast filling at Kirkwall due to not needing to pay for the ferry. However the cashflow looks remarkably similar, as shown in Figure 30.

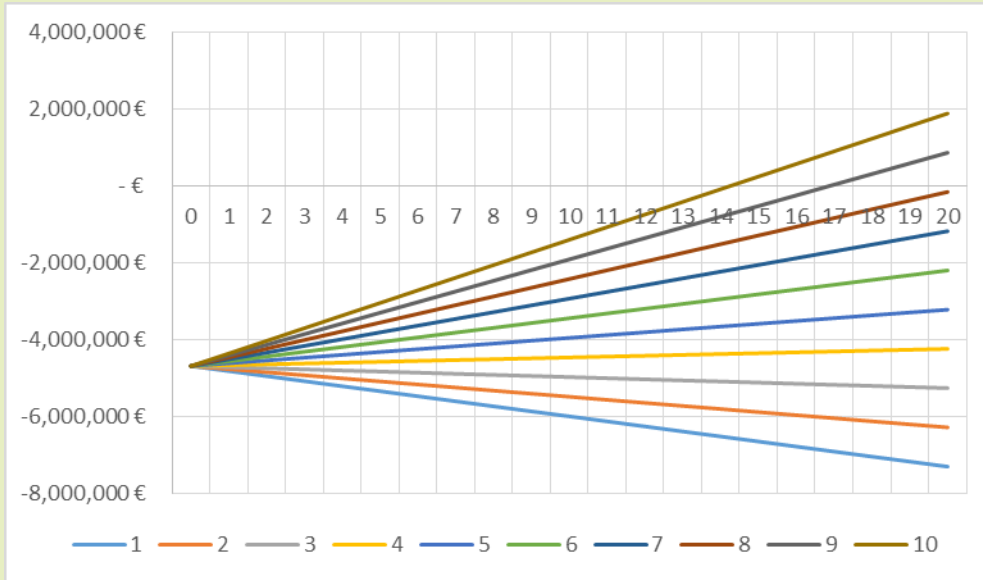

Figure 30. The modelling of cashflow for the slow filling at Shapinsay for a range of €/kg hydrogen sale prices

This indicates that breakeven at €10/kg can only be achieved by yr 14.

The breakdown of income and expenditure is provided in Figure 31.

DUAL Ports

De-carbonising port business today

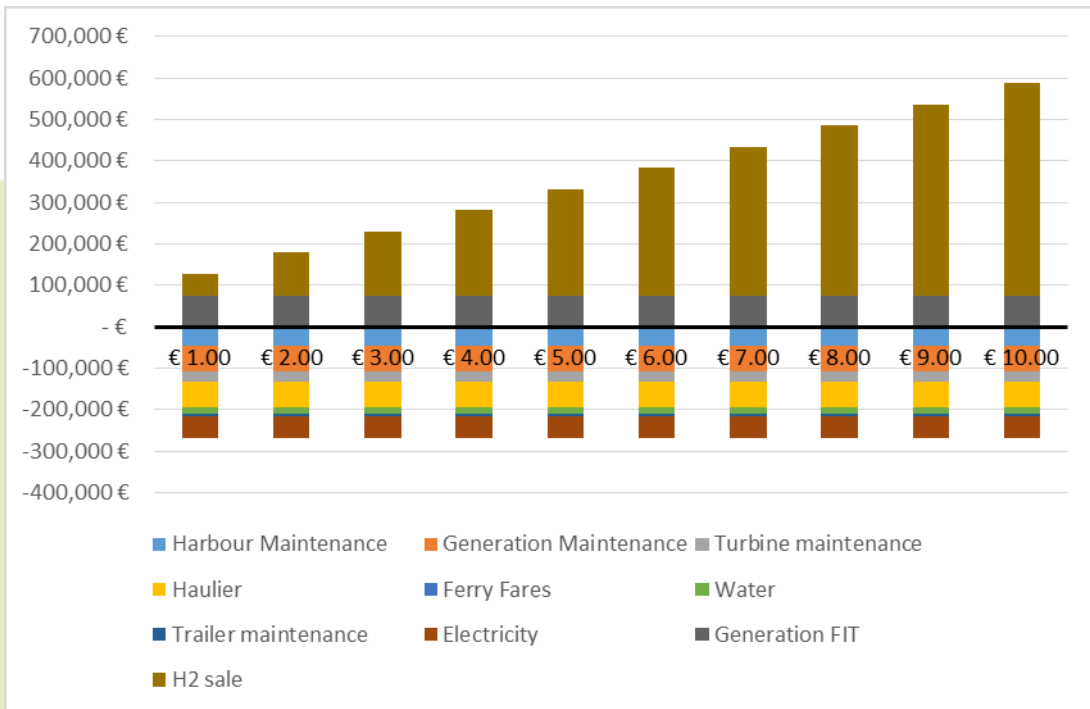

Figure 31. The breakdown of income and expenditure for the Shapinsay fill from tube trailers for a range of hydrogen sale prices (€/kg)

6.3 Slow Filling at Shapinsay via a 200bar Pipeline

This was modelled and presented in Figure 32.

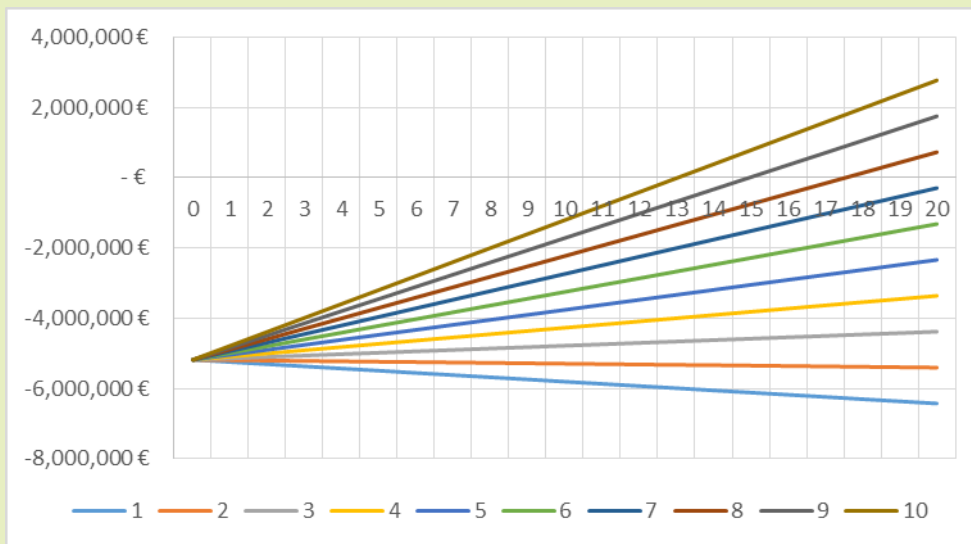

Figure 32. The cashflow from slow refuelling at Shapinsay via a 200 bar pipeline shown for varying €/kg

This indicates that breakeven at €10/kg can only be achieved by yr 13.

The breakdown of income and expenditure is provided in Figure 33.

DUAL Ports

De-carbonising port business today

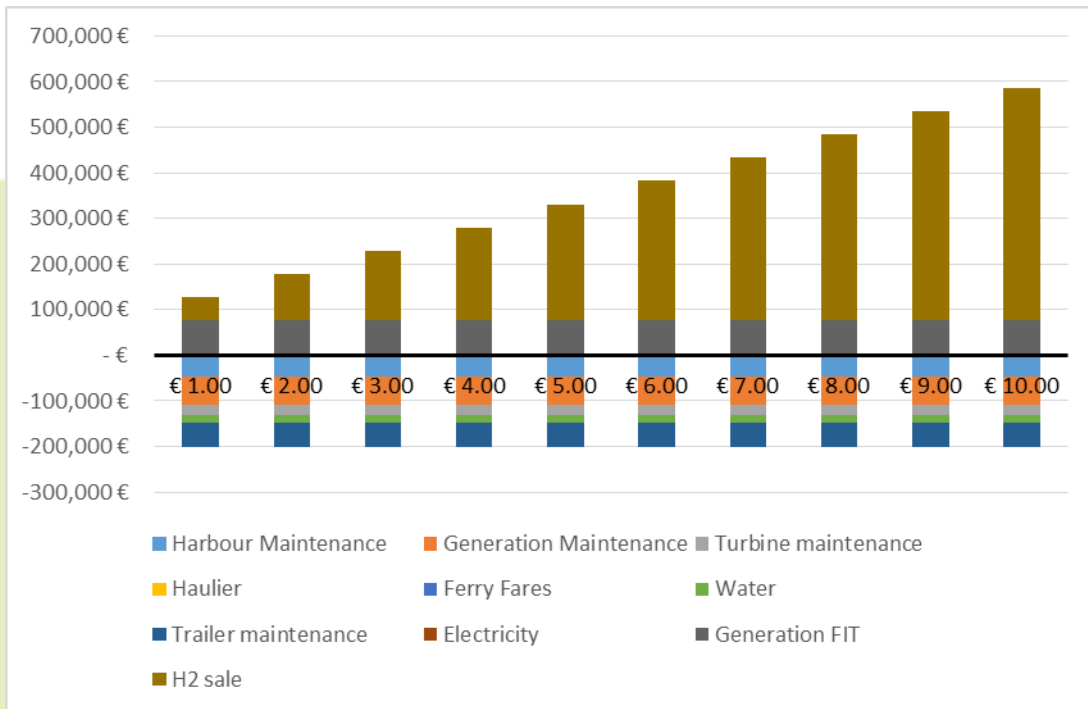

Figure 33. The breakdown of income and expenditure for a 200 bar pipeline for a range of hydrogen sale prices (€/kg)

6.4 Slow Filling at Shapinsay via a 350bar Pipeline

This was modelled and presented in Figure 34.

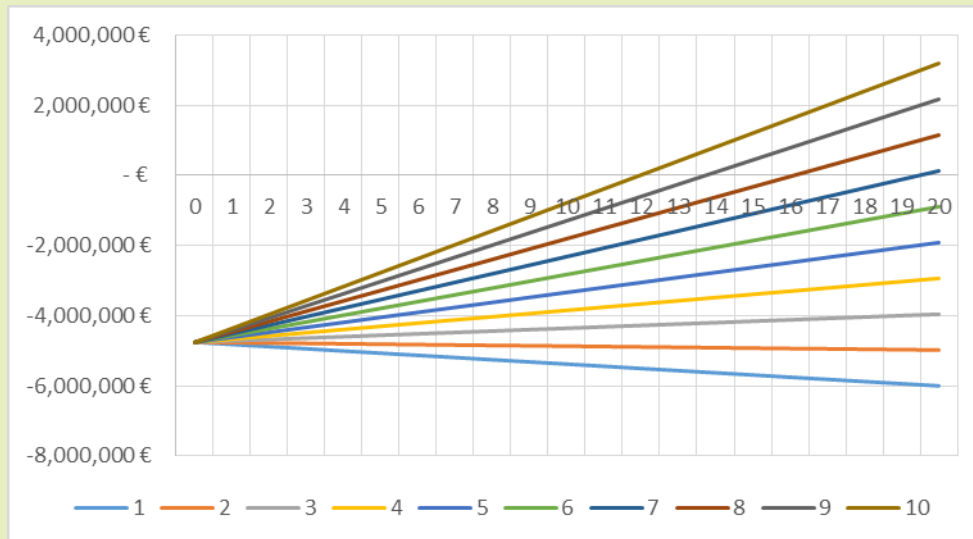

Figure 34. The cashflow from slow refuelling at Shapinsay via a 350 bar pipeline shown for varying €/kg

This indicates that breakeven at €10/kg can only be achieved by yr 13.

The breakdown of income and expenditure is presented in Figure 35.

DUAL Ports

De-carbonising port business today

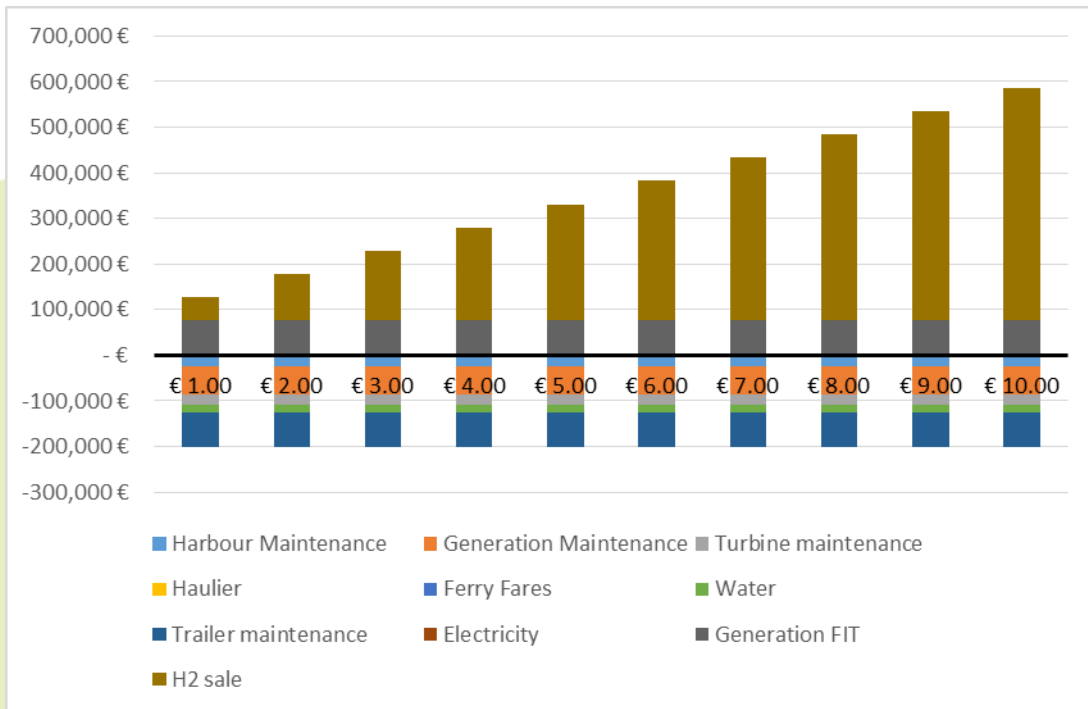

Figure 35. The breakdown of income and expenditure for the slow fill of vessels via a pipeline at Shapinsay Harbour for a range of hydrogen sale prices (€/kg)



The rate of return for the four scenarios modelled is presented in Figure 36:

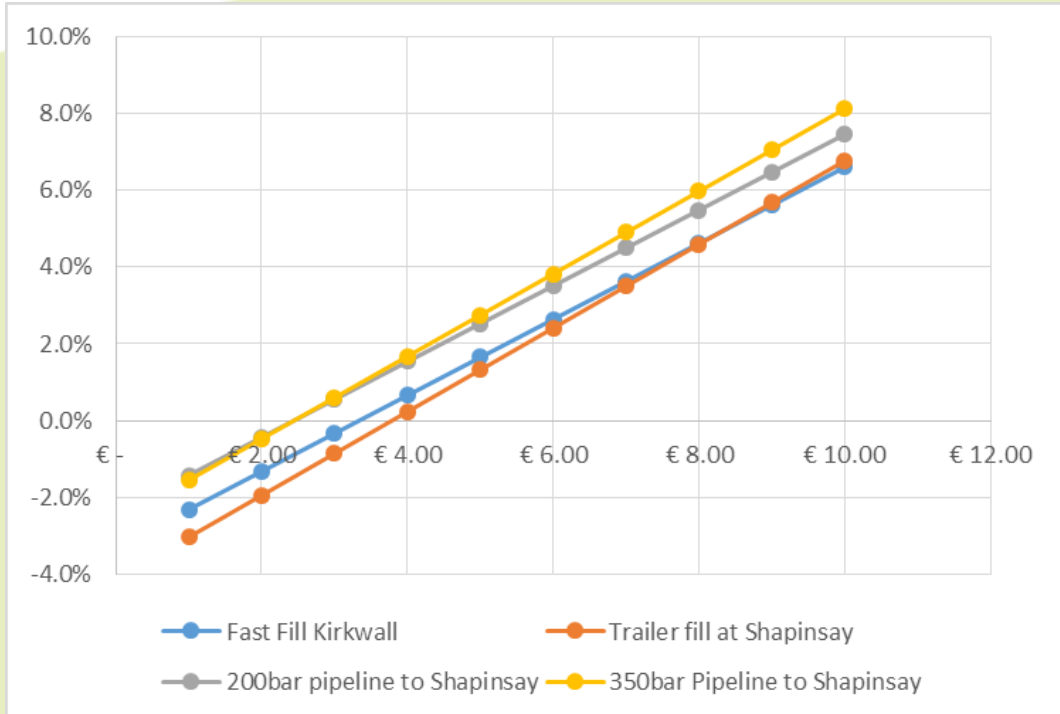

Figure 36. The rate of return for the different scenarios at a range of hydrogen sale prices

The best business case considered is for the 350bar pipeline supplying fuel to Shapinsay harbour.

A reasonable rate of return on a €4m investment would be 6-8%, therefore, irrespective of the arrangement of equipment chosen, the fuel price will be between €8.00/kg and €9.50/kg, Orkney Ferries are presently supplied marine fuel oil for the equivalent of €2.1/kg [14] and so there will be a significant rise in fuel price.

One key reason for the relatively high fuel price is the assumptions made about Orkney Ferries requirements of a bunkering system (99% availability and near zero carbon fuel).

Thus, to reduce the fuel price, the following could be changed:

- Grant support is sought for the cap-ex of the hydrogen generation
- Orkney Ferries accept either <99% availability or higher carbon hydrogen

ITM Power have:

- Investigated the generality of hydrogen as a fuel for vessels, including ways of using it, storing it and bunkering it. It was concluded that:
 - In a comparison between the safety of LH₂ and LNG both fuels present risks, with LH₂ probably being more dangerous if stored indoors and LPG probably more dangerous if stored outdoors.
 - In the medium to long term, liquid hydrogen is a viable solution for shipping. However, liquid hydrogen is presently largely unavailable. New production facilities are likely to be built as demand increases
 - In the short term, 350bar hydrogen is suitable for ferries. This was taken forward for further study as this vessel is likely to be available to Orkney, where this pilot is based.
- Designed a 350 bar hydrogen bunkering system that is modular and scalable, so that it can be adapted to any given customer.
- Applied that design to the specific location of Orkney. Four scenarios for arranging the equipment were considered in detail, with modelling undertaken of available power and the storage required to achieve the required availability. All equipment was specified with detailed data tables presented.
- The four scenarios were taken forward for modelling of the business case. The best solution was the 350 bar pipeline supplying hydrogen to Shapinsay harbour. However, to achieve a reasonable rate of return, the fuel price will need to be higher than Orkney Ferries are presently paying. To overcome this issue, it is recommended to seek grant funding for the bunkering system, lower the assumed 99% availability requirement or the assumed requirement for a low carbon fuel.

8 References

- [1] BBC, "Shipping industry faces calls to clean up emissions," 9th April 2018. [Online]. Available: <http://www.bbc.co.uk/news/business-43696900>. [Accessed 20th April 2018].
- [2] International Marine Organisation, "Marine Environment Protection Committee (MEPC), 72nd session, 9-13 April 2018," 13 April 2018. [Online]. Available: <http://www.imo.org/en/MediaCentre/MeetingSummaries/MEPC/Pages/MEPC-72nd-session.aspx>. [Accessed 20th April 2018].
- [3] LNG World Shipping, "The world's LNG-fuelled ships on order, 2017," April 2017. [Online]. Available: http://www.lngworldshipping.com/news/view,the-worlds-lngfuelled-ships-on-order-2017_47089.htm. [Accessed 20th April 2018].
- [4] New Energy and New Fuel, "Energy Density Specific Energy Graph," 3 May 2009. [Online]. Available: <https://newenergyandfuel.com/http://newenergyandfuel.com/2009/05/06/storing-energy-the-terms-and-the-payoff-to-consumers/energy-density-specific-energy-graph/>. [Accessed 20 April 2018].
- [5] Seeking Alpha, "Tesla's First Decade Of Battery Pack Progress - Much Ado About Nothing," 25 August 2017. [Online]. Available: <https://seekingalpha.com/article/4101993-teslas-first-decade-battery-pack-progress-much-ado-nothing>. [Accessed 24th April 2018].
- [6] R. Zacharia, "Review of Solid State Hydrogen Storage Methods Adopting Different Kinds of Novel Materials," *Journal of Nanomaterials*, vol. 9, pp. 1-18, 2015.
- [7] Open Chemistry Database, "Hydrogen," 2018.
- [8] The International Group of Liquefied Natural Gas Importers, "LNG Information Paper No. 1," 2009.
- [9] Sandia National Laboratory, "Feasibility of the SF-BREEZE: a Zero-Emission, Hydrogen Fuel Cell, High-Speed Passenger Ferry," 2018.
- [10] US Department of Energy, "The Impact of Increased Use of Hydrogen on Petroleum Consumption and Carbon Dioxide Emissions," Washington, 2008.
- [11] I. Uehara, "Handling and Safety of Hydrogen," *Energy Carriers and Conversion Systems*, vol. 1, 2013.
- [12] The Engineering Tool Box, "Fuel Gases and Wobbe Index," [Online]. Available: https://www.engineeringtoolbox.com/wobbe-index-d_421.html. [Accessed 11th May 2018].

DUAL Ports

De-carbonising port business today

- [13] Engineering Toolbox, “Fuels - Higher and Lower Calorific Values,” [Online]. Available: https://www.engineeringtoolbox.com/fuels-higher-calorific-values-d_169.html. [Accessed 11th May 2018].
- [14] Orkney Marine Services, *Personal Communication*, 2018.
- [15] Neutrium, “Specific Energy and Energy Density of Fuels,” 26th March 2014. [Online]. Available: <https://neutrium.net/properties/specific-energy-and-energy-density-of-fuels/>. [Accessed 16th May 2018].
- [16] ITM Power PLC, “BIG HIT Deliverable 2.1,” 2017.
- [17] A. a. L. L. Moro, “Electricity carbon intensity in European Member States: Impacts on GHG emissions of electric vehicles,” *Transportation Research Part D: Transport and Environment*, vol. D, pp. 1-10, 2017.



De-carbonising port business today

9 Appendix 1: Maintaining Supply when Connected to a Wind Turbine

9.1 Basic Turbine Data

Data has been obtained from a 900kW wind turbine base in Orkney, where the bunkering system is intended to be located. Modelling has been undertaken to determine a series of metrics including store size and electricity cost. The results should be scalable, so that if a result indicates that a certain kg/day demand is possible, two turbines will produce enough hydrogen for twice the demand consumption.



The wind speed at the site is presented below:

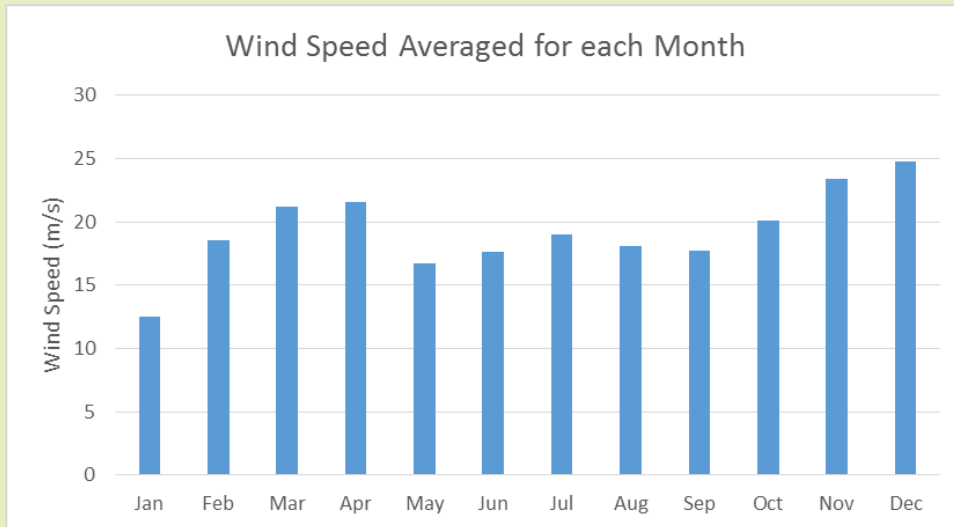

Figure 37. The monthly wind speed at the Orkney 900kW wind turbine.

The monthly output is:

DUAL Ports

De-carbonising port business today

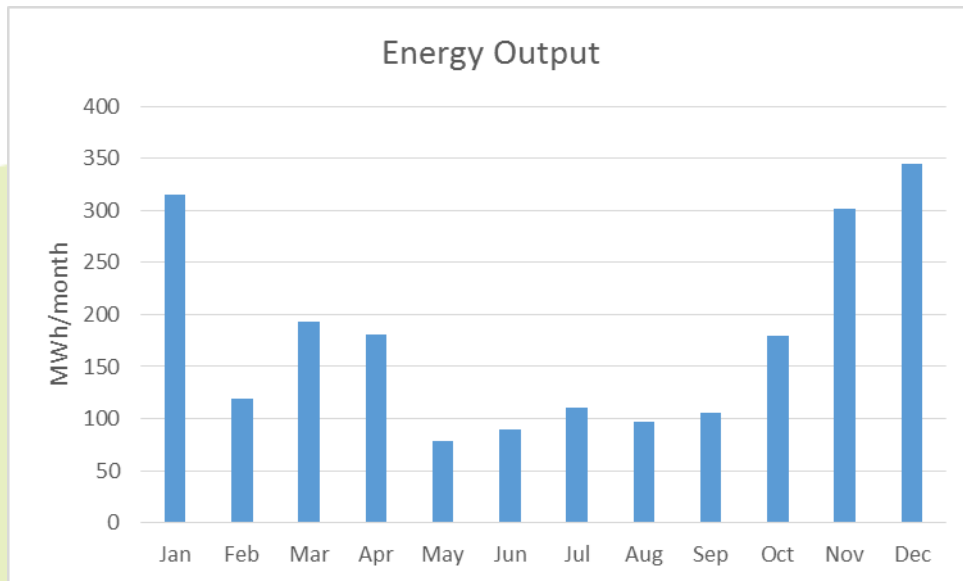

Figure 38. Monthly energy output from a 900kW wind turbine in Orkney.

However, in Orkney an Active Network Management (ANM) system is in place that curtails the output from wind turbines, preventing the energy entering the grid. The energy is lost to the turbine owner, providing them with neither a sale price nor a Feed In Tariff (FIT) income.

Based on the turbine power curve and the measured wind speed in Figure 37, the expected output of the turbine is expected to be:

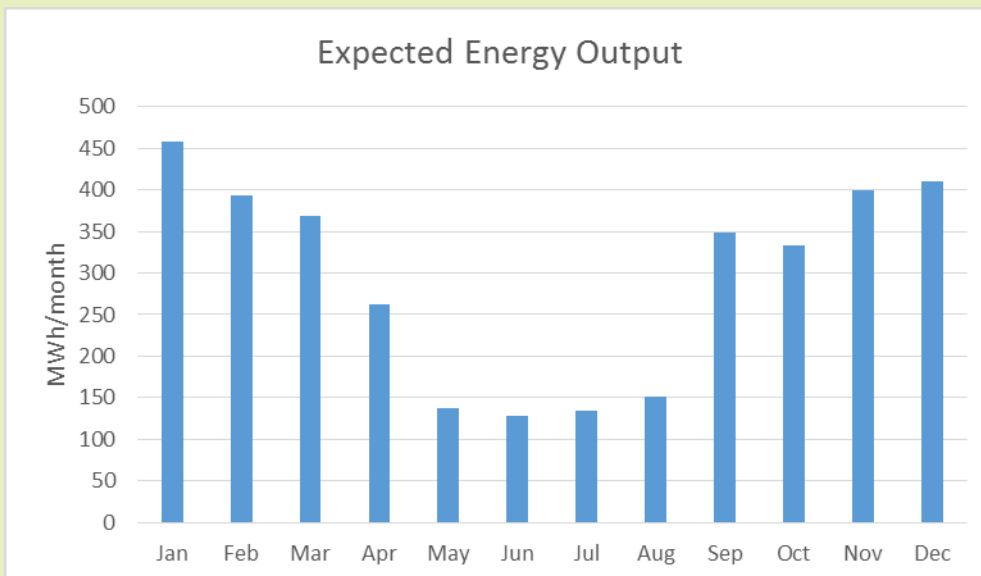

Figure 39. The expected output of the 900kW wind turbine.

By subtracting the data in Figure 38 from the data in Figure 39, it is possible to deduce the amount of curtailed energy each month:

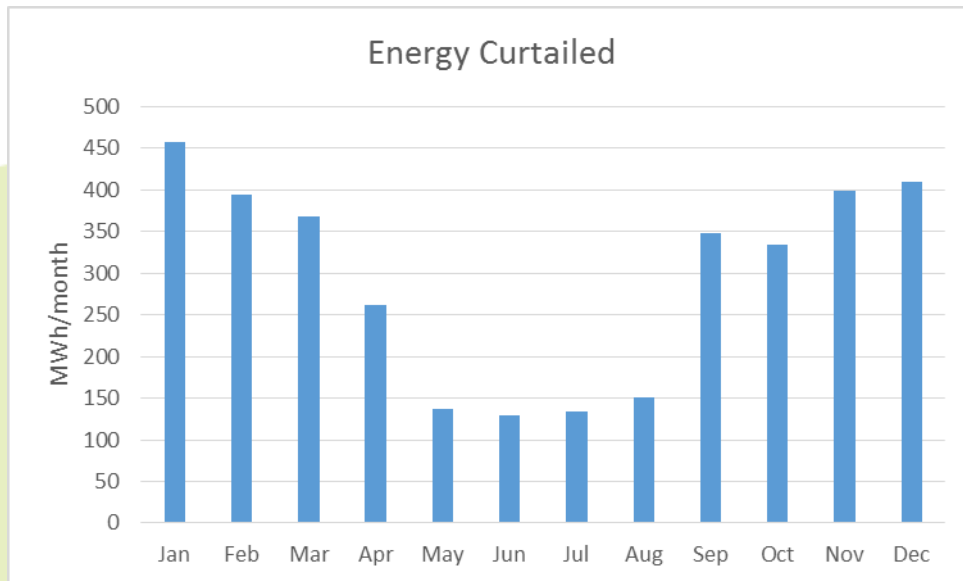

Figure 40. The calculated curtailed energy of the system.

This energy is both carbon free and zero-priced. Indeed by taking the energy, the turbine owner can claim the generation FIT, allowing the possibility that they may price the electricity slightly negatively. This makes this energy ideal as an input to the electrolyser. However, as can be seen from Figure 40, its curtailed energy availability is not evenly distributed throughout the year. On a daily basis, even greater distribution is found:

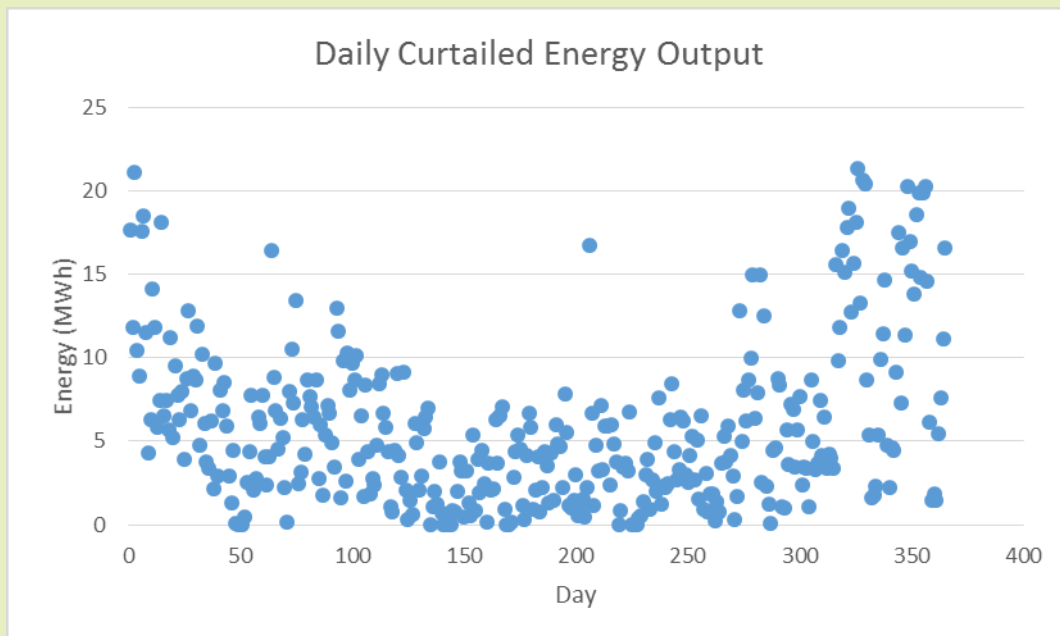

Figure 41. The daily curtailed energy output.

Based on the electrolyser's efficiency curve (an example of which is shown in Figure 20), the output can be converted into a kg H₂/day, averaged over the month:

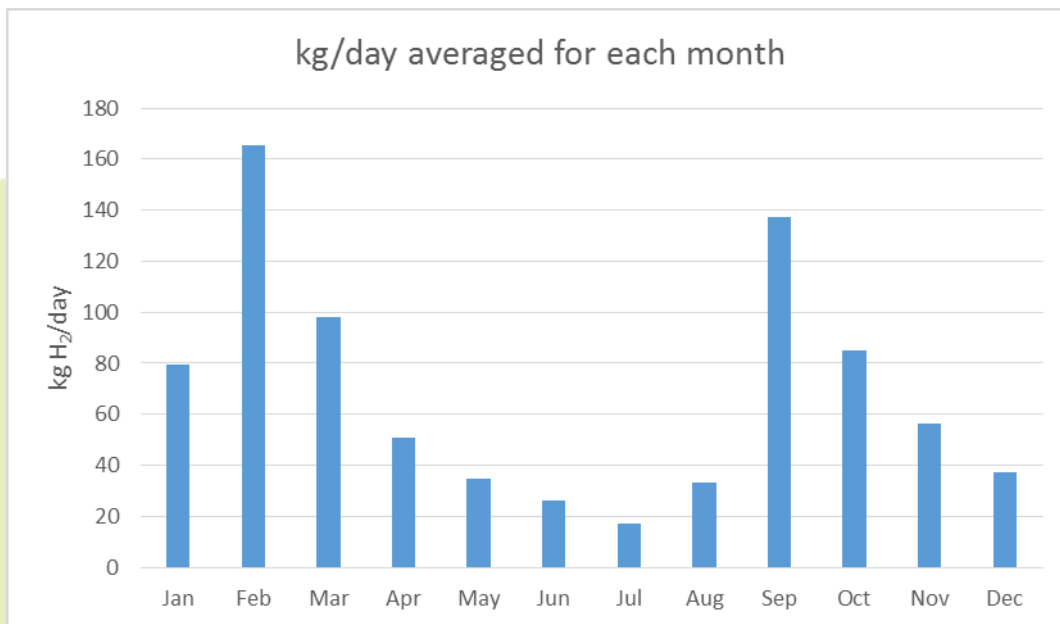

Figure 42. Electrolyser output of hydrogen each day, averaged over each month.

This shows that in July, the average (not minimum) daily output from the 900kW turbine is 17kg/day. This should be compared to 900kW available continuously from the grid, which will produce ~360kg/day. Thus, despite the considerable advantages of using curtailed energy to power the system.

9.2 Storage Requirements based on only using Curtailed Energy

However, based on this data, even if a ferry consuming 17kg/day was purchased, storage is needed to smooth out the variation in daily consumption. Indeed, to only meet this unambitious average production, 160kg of storage is required; the graph showing the store level is presented in Figure 43.

DUAL Ports

De-carbonising port business today

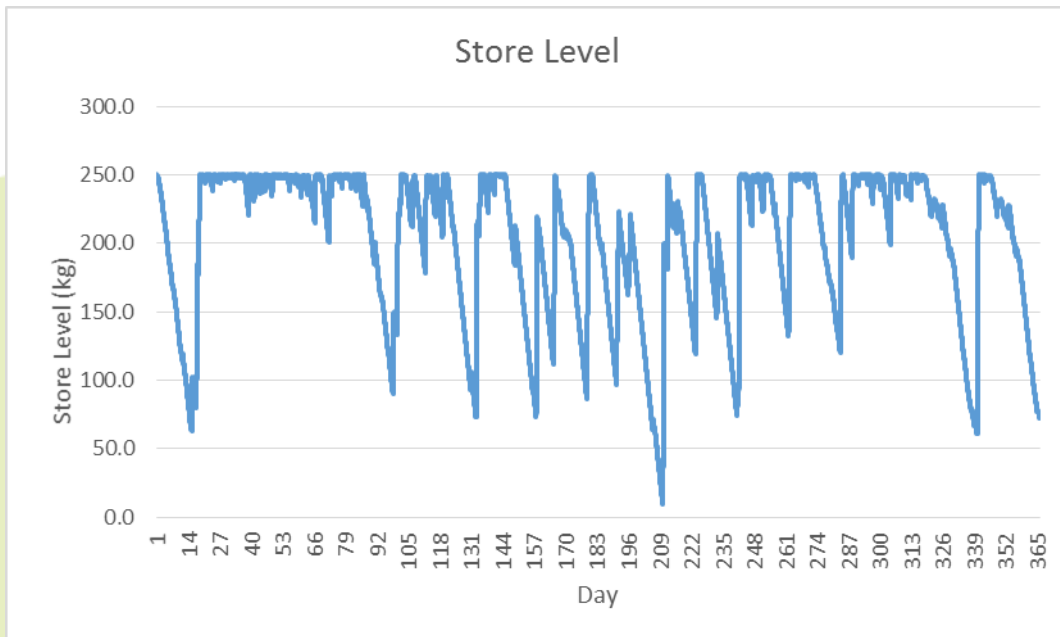

Figure 43. Store level variation throughout the year, demonstrating that 250kg is required to maintain 17kg/day output.

Following this method, the store size was calculated for different daily demands of hydrogen. The variation in store levels is shown in Figure 44. Note that this modelling assumes that the store level starts full at the beginning of the year, and in all cases they are not full at the end of the year. This lack of balance suggests that the store levels need to be even higher than indicated.

DUAL Ports

De-carbonising port business today

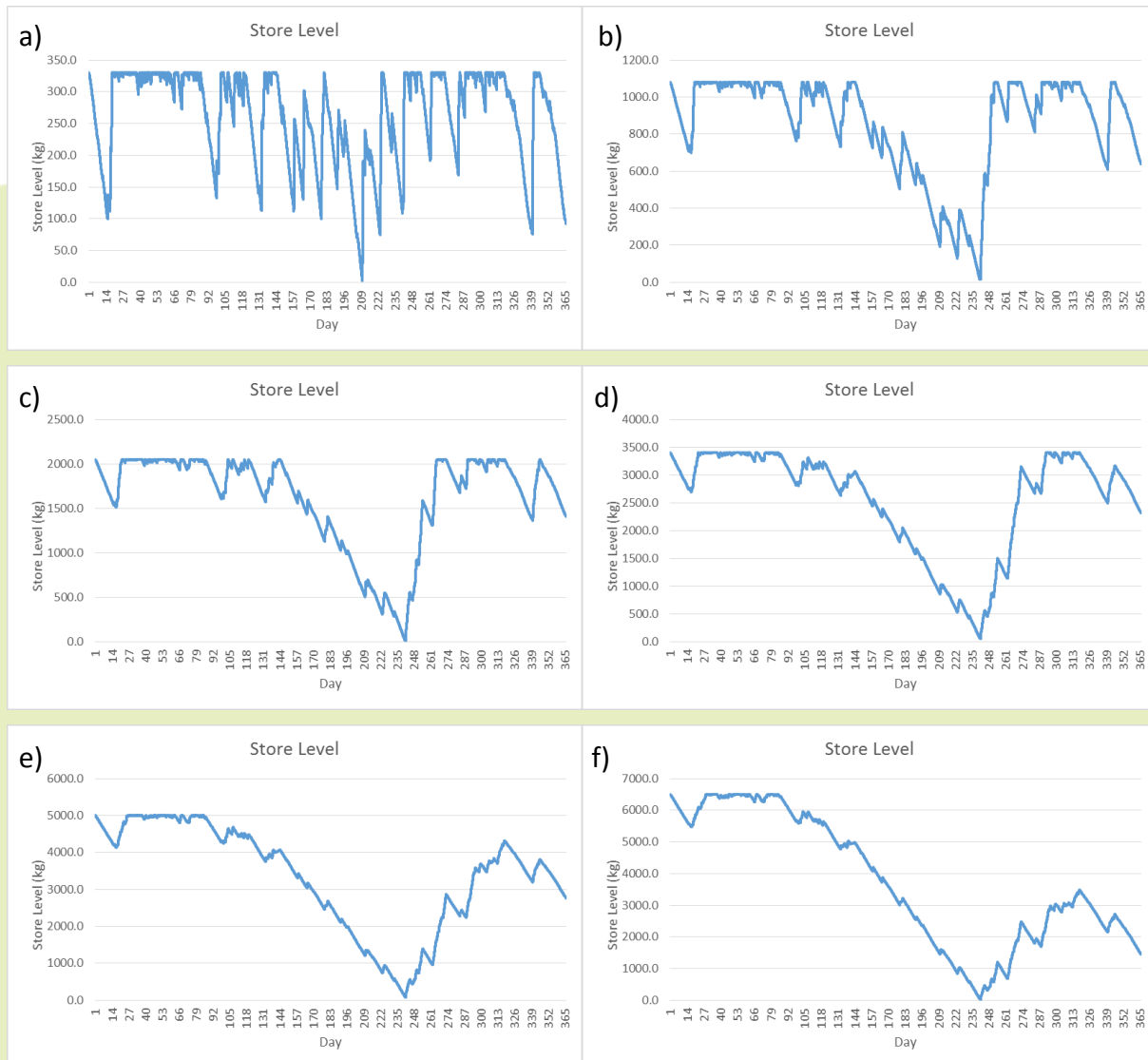

Figure 44. The storage level variation throughout the year that is required to maintain a daily output of a) 20kg/day, b) 30 kg/day, c) 40 kg/day, d) 50 kg/day, e) 60 kg/day and f) 70 kg/day.

These results are summarised in Figure 45.



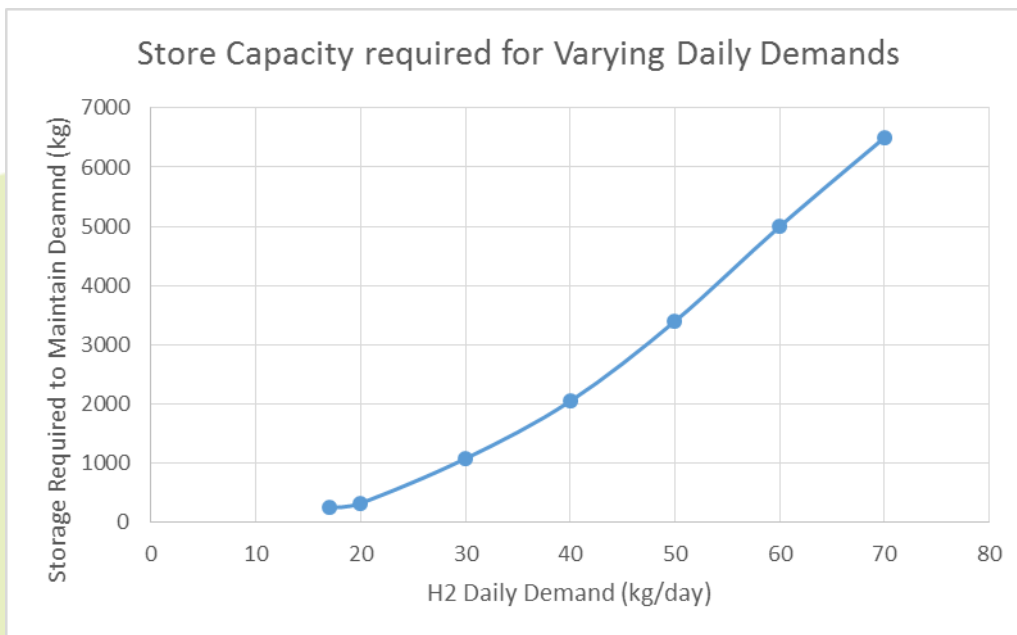

Figure 45. Summary of the storage required to maintain various daily outputs of hydrogen

With storage costs of ~£700/kg, it can be seen that when running from only curtailed energy, the cap-ex requirements for even low levels of daily hydrogen demand are significant.

9.3 Storage Requirements based on using Curtailed and Uncurtailed Energy

The first option to reduce this capex is to use the turbine’s uncurtailed energy. For the particular turbine studied here, it had a power purchase agreement (PPA) which would prevent the turbine owner selling power to anyone else; however, if planned properly from the purchase of the turbine, this approach is feasible. The electricity provided would still be zero carbon, but rather than being zero priced, it would have a value equal to the sale price of the electricity. This varies throughout the day, but an average value of €60 /MWh is not unreasonable.

A logic was modelled, whereby if the store level was at <50%, the uncurtailed energy would be used to generate electricity in preference to further depleting the store. However, this uncurtailed energy is not always available, therefore store levels often continue to fall. An example of the store level variation including curtailed energy, with the largest demand considered (70 kg/day) is presented in Figure 46.

DUAL Ports

De-carbonising port business today

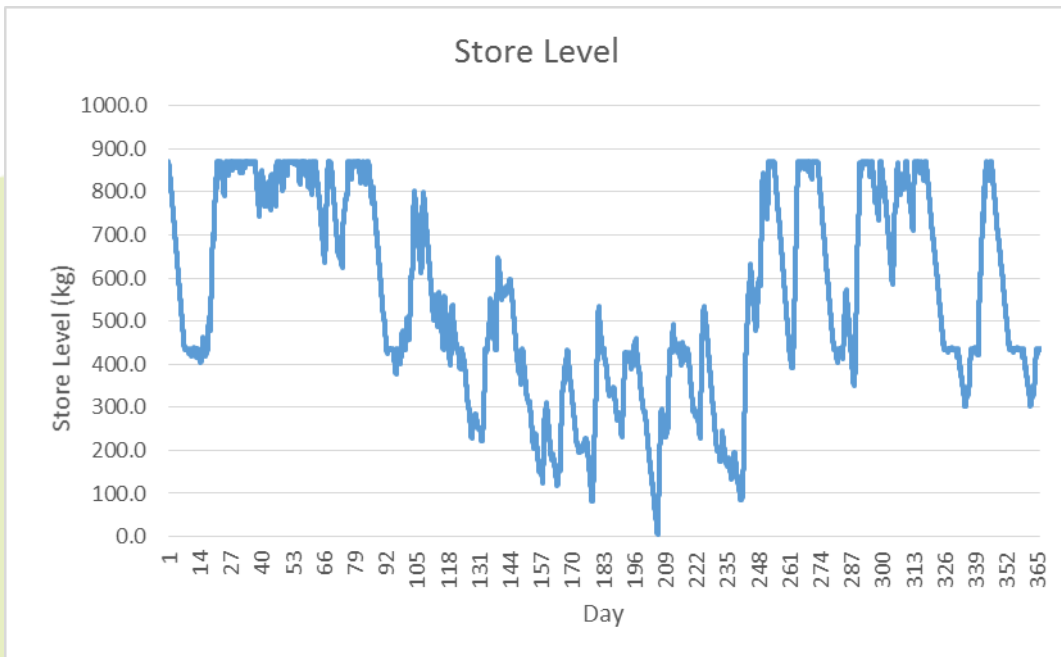

Figure 46. The store level for a demand of 150 kg/day, utilising uncurtailed energy if the store level is <50%.

When applied to a variety of daily demands for hydrogen, the store size was calculated and converted into a Cap-Ex cost and annualised electricity cost. This was plotted against the pure curtailed data, and is presented in Figure 47.

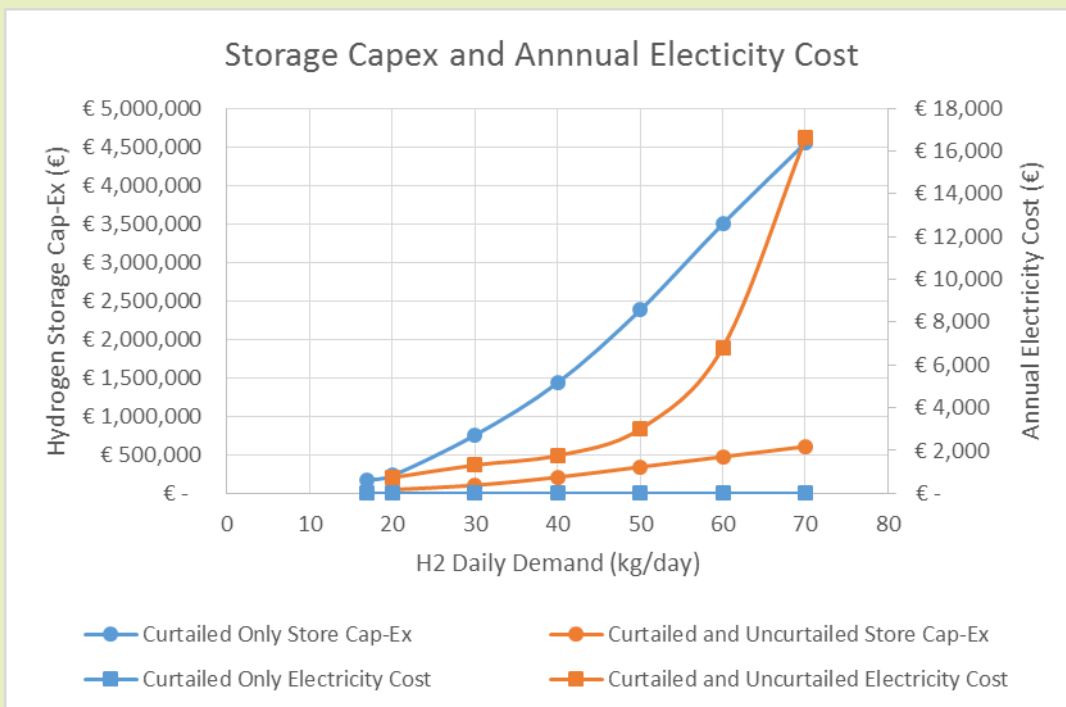

Figure 47. Comparing the storage cap-ex and annual electricity cost for maintaining varying levels of daily H₂ demand, for using only curtailed energy and a mix of curtailed and uncurtailed.

De-carbonising port business today

This shows that order of magnitude scale reductions in Cap-Ex (amounting to millions of Euro's can be achieved for relatively modest increases in annual electricity cost. Therefore, if the turbines PPA can be arranged, then this approach is recommended.

9.4 Storage Requirements based on using Curtailed, Uncurtailed and Grid Energy

Grid electricity is expensive and in most locations carbon intensive, and therefore should be avoided. However, if grid electricity is used, its will have a significant effect on the storage levels. The model was set up to revert to grid electricity if the store falls to 25% of its maximum value; however, because the grid power can always produce more hydrogen than the demand, the store level will never fall below 25%. Thus, for each demand it is not possible to set a minimum store level as has been done previously, because even a negligibly sized store will never drop below 25% full, but at the expense of both electricity price and carbon footprint.

To demonstrate this effect, a fixed daily demand of 60 kg/H₂ was selected, the storage level was varied and the effect on Cap-Ex and electricity cost was calculated. This is presented in Figure 48.

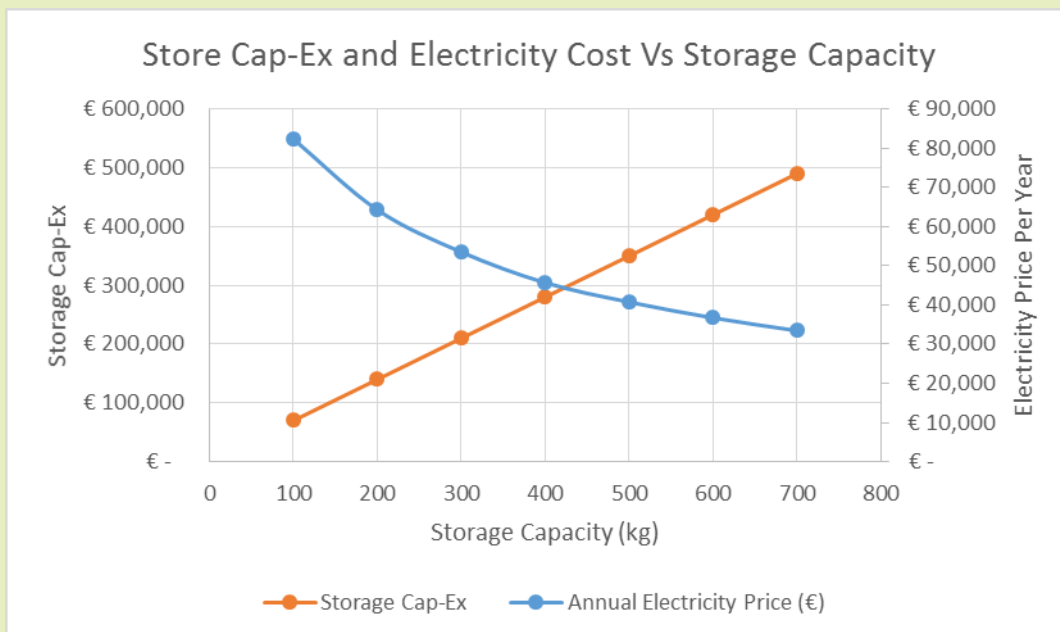

Figure 48. For a fixed daily demand of 60 kg/day, the storage Cap-Ex and annual electricity costs for varying storage capacity

Assuming a lifetime of 20 yrs a simplified¹⁶ total expenditure can be calculated, as shown in Figure 49.

¹⁶ Excluding features such as the WACC and inflation.

DUAL Ports

De-carbonising port business today

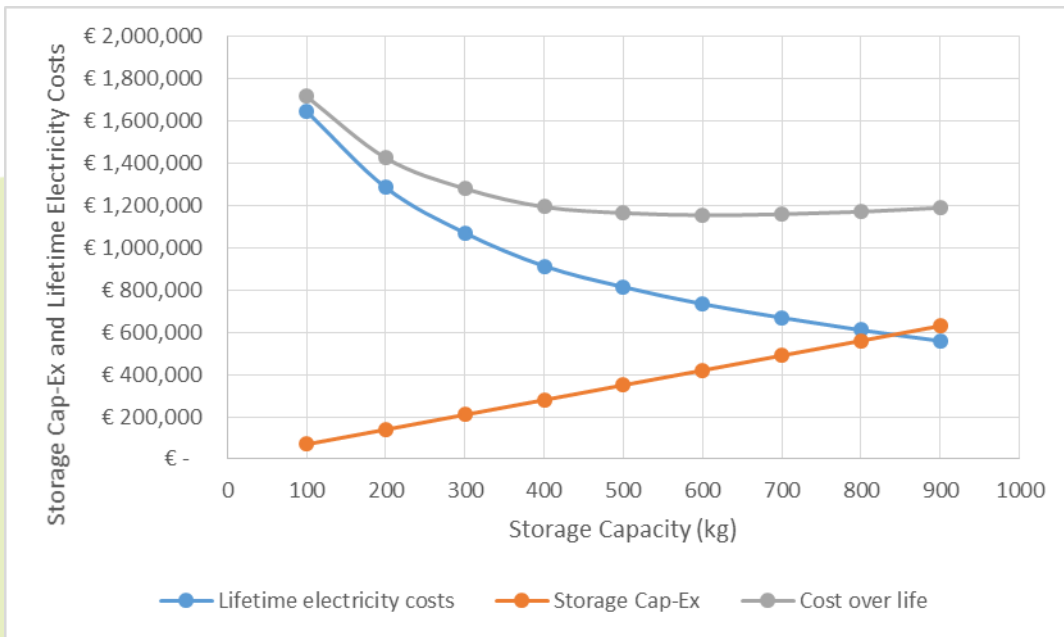

Figure 49. For a fixed daily demand of 60kg/day, the storage Cap-Ex, lifetime electricity price and total expenditure

It can be seen that using grid electricity significantly reduces the quantity of storage required, with a minimum cost over life achieved at ~600kg of storage, compared to 5,000 kg using only uncurtailed power. At 600kg of storage, the level variation throughout the year is shown in Figure 50.

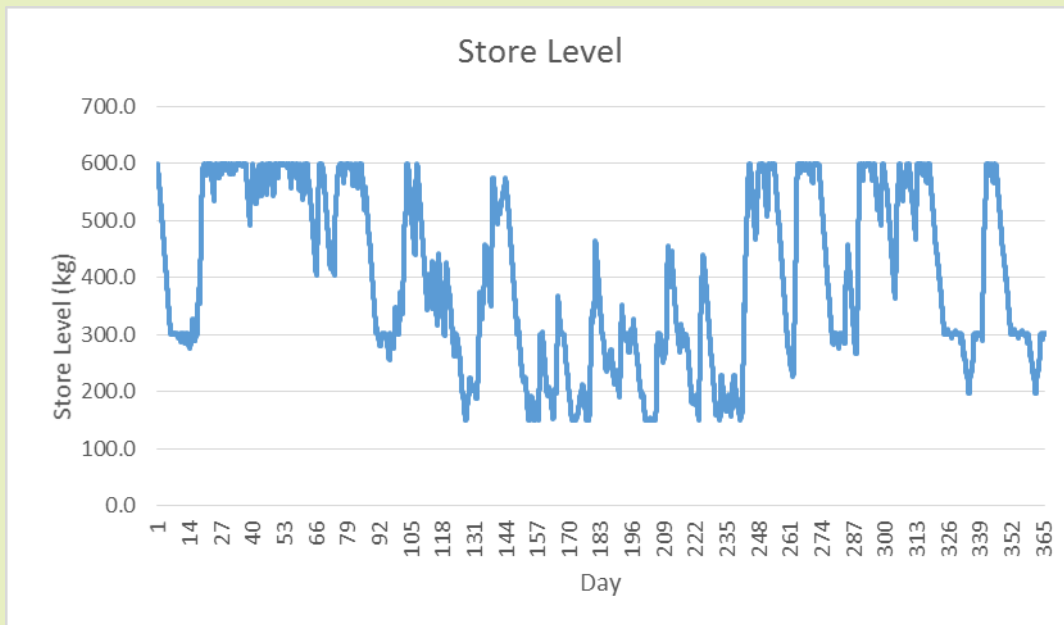

Figure 50. Using curtailed, uncurtailed and grid power with a demand of 60kg/day with 600kg of storage.

Thus, in purely in economic terms, reducing storage by increasing use of grid electricity is beneficial, but it will increase the carbon intensity of the hydrogen produced.

De-carbonising port business today

10 Appendix 2: Hydrogen Required for Cascade Filling

If the ship's target pressure is 350 bar, then if the land based storage drops below this pressure then it is unable to refuel, meaning that most of the hydrogen storage on land is inaccessible to the ship.

This problem is accentuated due to hydrogen being a diatomic gas and therefore a 'non-ideal' gas, meaning that the physical space of the molecule affects the way that the gas behaves when compressed. Thus, when the pressure is doubled, the gas density increases by slightly less than two.

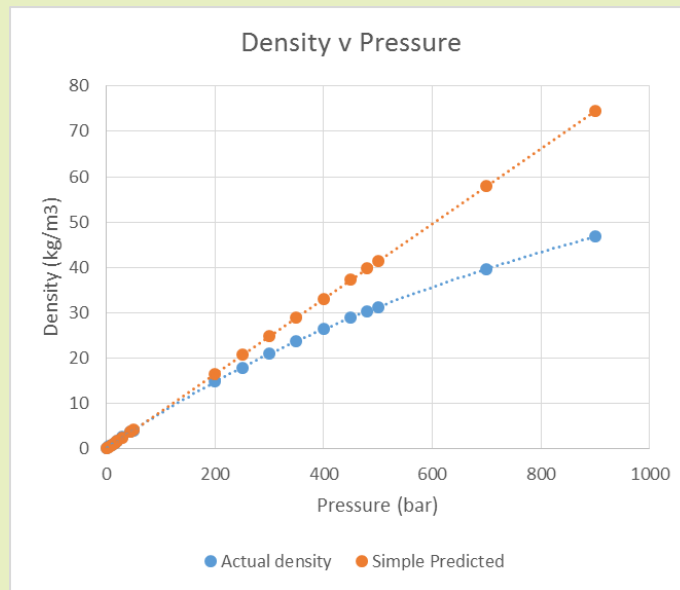

Figure 51. Hydrogen density v's pressure, showing the linear relationship that might be expected and the non-linear actual relationship.

It can be seen that at low pressures, the deviation from ideal to non-ideal gases is negligible, however, above 200 bar the effect becomes significant.

As such, to fill a ship with 500 kg of hydrogen at 350 bar requires 2,070kg of 500 bar storage.